

● Notice de montage ● Installation instructions  
● Istruzioni di montaggio  
● Montage-instructies ● Montageanleitung

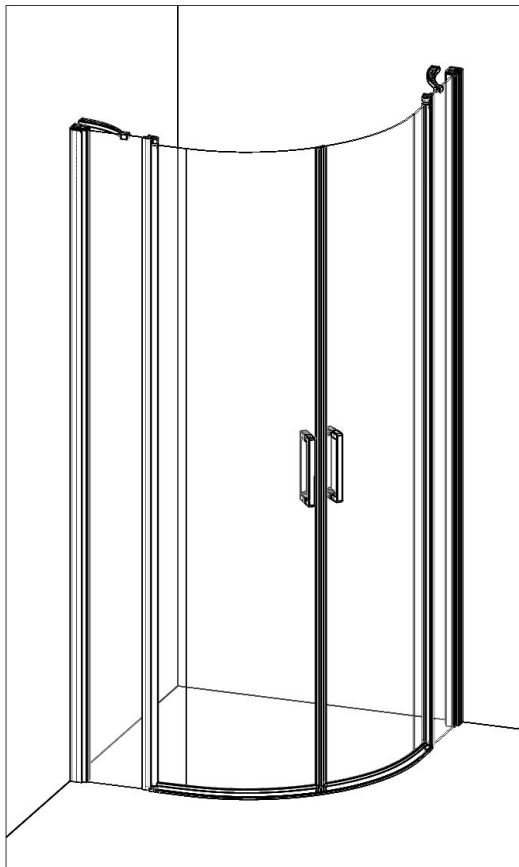







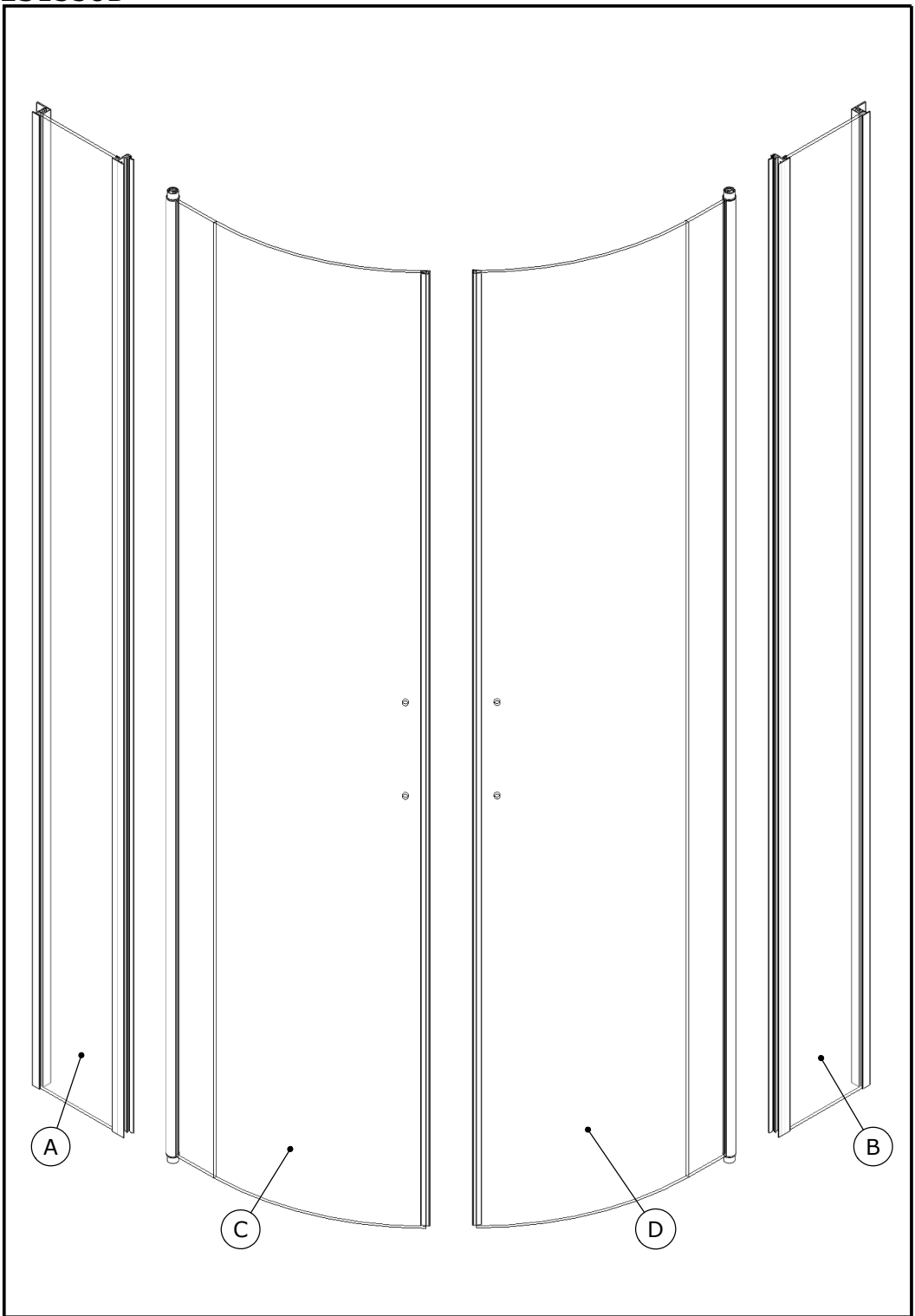

Notre service technique est  
à votre écoute aux numéros  
qui sont au dos de cette  
notice d'installation

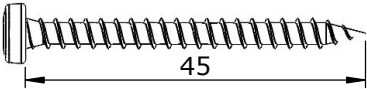

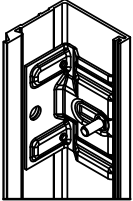
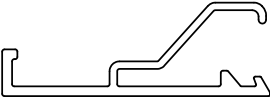
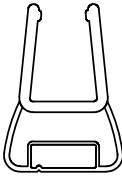
- Attention aux étapes :
- Check installation steps :
- Atención a los pasos :
- Attenzione ai passi :
- Aandacht voor de stappen :
- Achtung vor den Schritten :

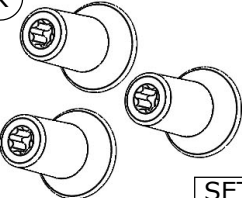
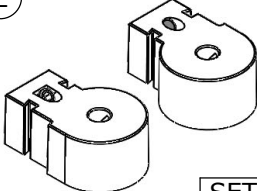
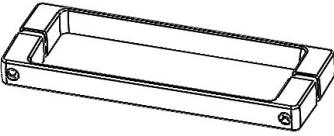
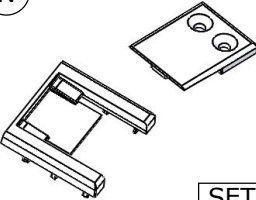
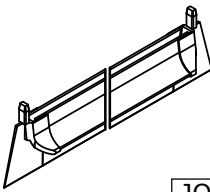
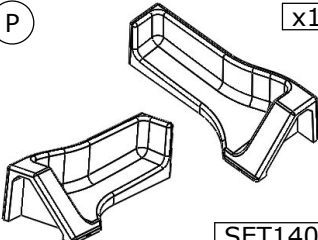
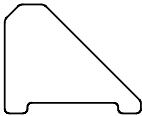
P. 5 - 13 - 31

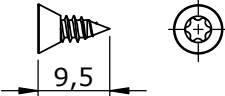
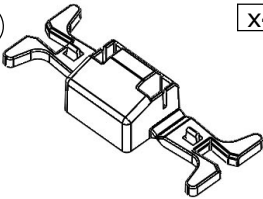

<p><b>E</b> <math>\varnothing 3.5\text{mm}</math> <span style="float: right;">x6</span></p>  <p style="text-align: center;">45</p> <p style="text-align: right;">VIS231</p>	<p><b>F</b> <span style="float: right;">x6</span></p>  <p style="text-align: right;">CHE02</p>	
<p><b>G</b> <span style="float: right;">x2</span></p>  <p style="text-align: right;">6268</p>	<p><b>H</b> <span style="float: right;">x2</span></p>  <p style="text-align: right;">6270</p>	<p><b>I</b> <span style="float: right;">x2</span></p>  <p>Lg = 1952mm <span style="float: right;">AI174</span></p>
<p><b>J</b> <span style="float: right;">x2</span></p>  <p style="text-align: right;">PPL1248</p>	<p><b>K</b> <span style="float: right;">x2</span></p>  <p style="text-align: right;">SET134</p>	<p><b>L</b> <span style="float: right;">x2</span></p>  <p style="text-align: right;">SET128</p>
<p><b>M</b> <span style="float: right;">x2</span></p>  <p style="text-align: right;">PGN49</p>	<p><b>N</b> <span style="float: right;">x2</span></p>  <p style="text-align: right;">SET137</p>	<p><b>O</b> <span style="float: right;">x1</span></p>  <p style="text-align: right;">JOI145</p>
<p><b>P</b> <span style="float: right;">x1</span></p>  <p style="text-align: right;">SET140</p>	<p><b>Q</b> <span style="float: right;">x1</span></p>  <p style="text-align: right;">6285</p>	<p><b>R</b> <span style="float: right;">x1</span></p>  <p style="text-align: right;">SUP129</p>
<p><b>S</b> <math>\varnothing 3.5\text{mm}</math> <span style="float: right;">x2</span></p>  <p style="text-align: center;">9,5</p> <p style="text-align: right;">VIS261</p>	<p><b>T</b> <span style="float: right;">x4</span></p>  <p style="text-align: right;">PPL1339</p>	<p><b>U</b> <span style="float: right;">x1</span></p>  <p style="text-align: right;">SUP130</p>

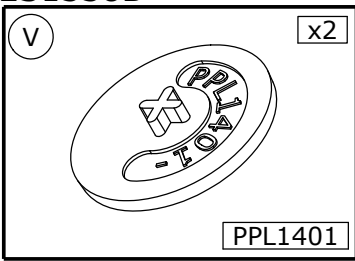

- Les quantités données sont les quantités utiles au montage. les sachets fournis contiennent des pièces supplémentaires.
- The quantities given are what are required for the installation. There may be some surplus in the package provide.
- Le quantità fornite sono le quantità necessarie al montaggio. I sacchetti forniti contengono pezzi supplementari.
- De aangegeven aantallen zijn vereist voor de montage. De verpakking bevat extra onderdelen.
- Die Mengenangaben beziehen sich auf die für die Montage nötigen Teile. Eventuell weitere beige packte Teile ignorieren.

Ⓕ Matériel nécessaire ⒼⒹ Tools required

Ⓕ Materiale necessario ⒼⒹ Benodigd gereedschap ⒹⒹ Benötigte Werkzeuge

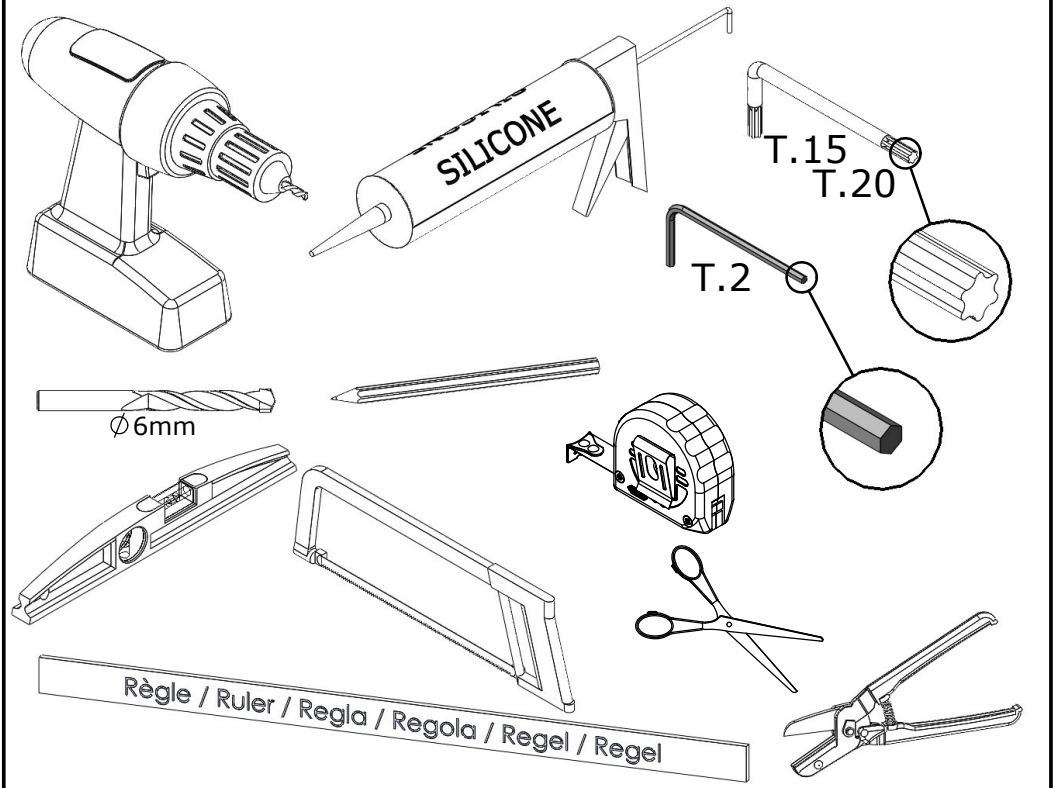

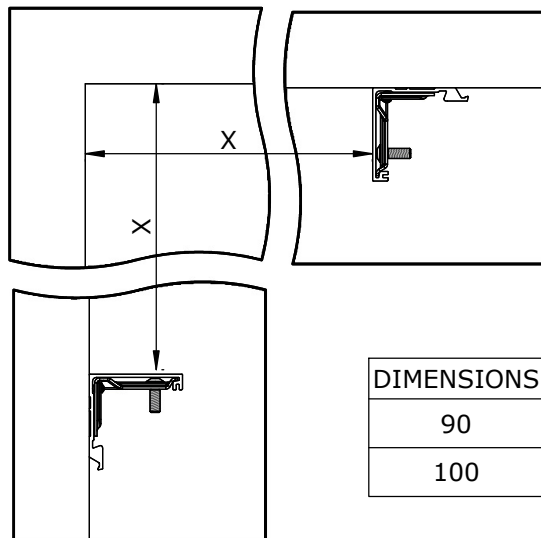
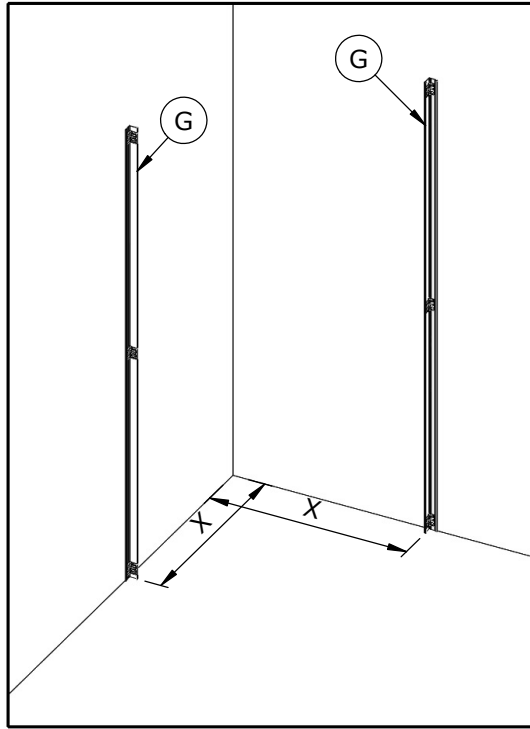

DIMENSIONS	X
90	830 - 845
100	930 - 945

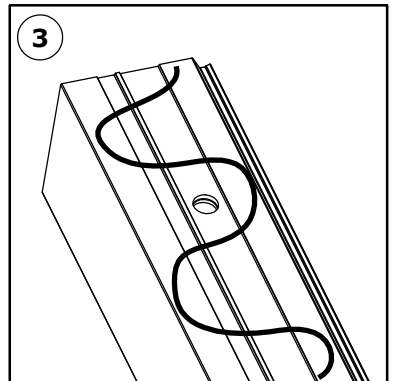
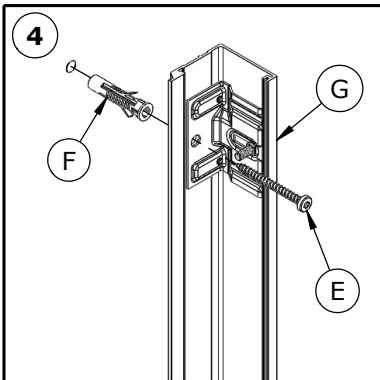
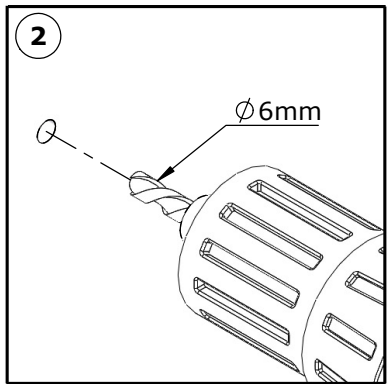
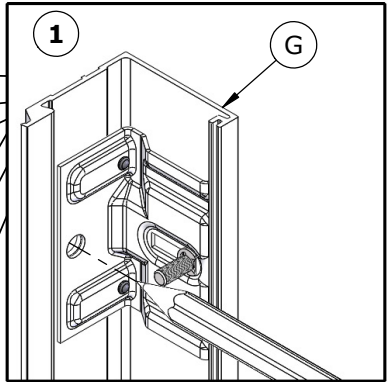
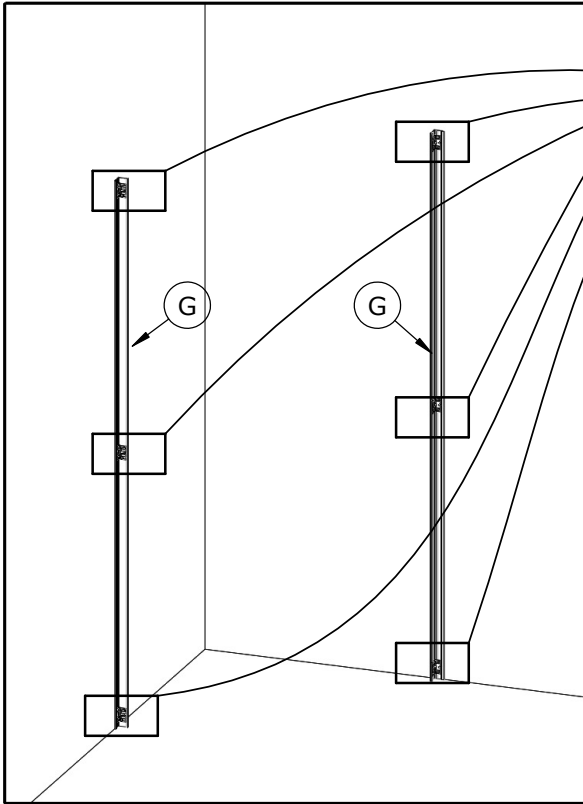

A

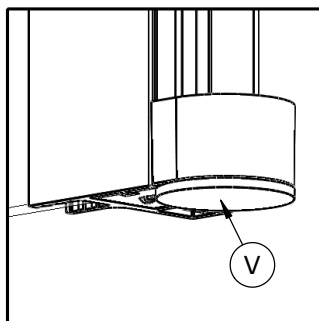
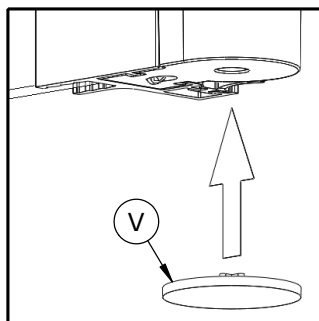
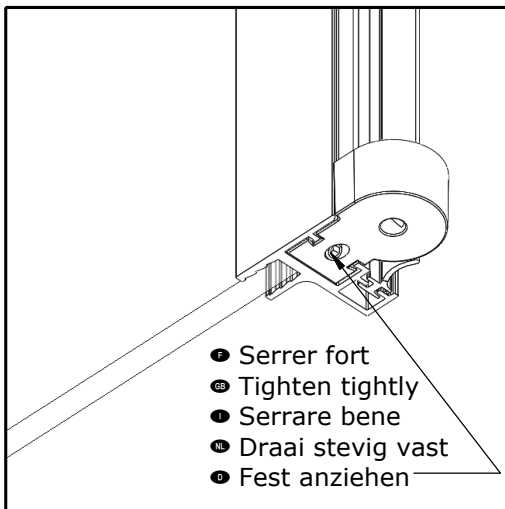
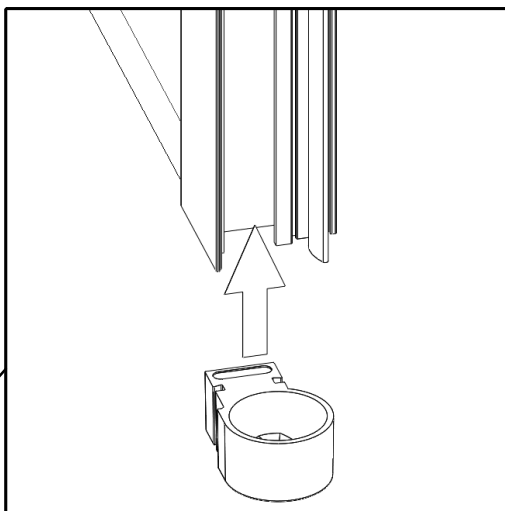
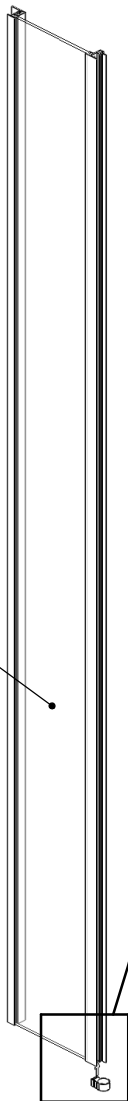

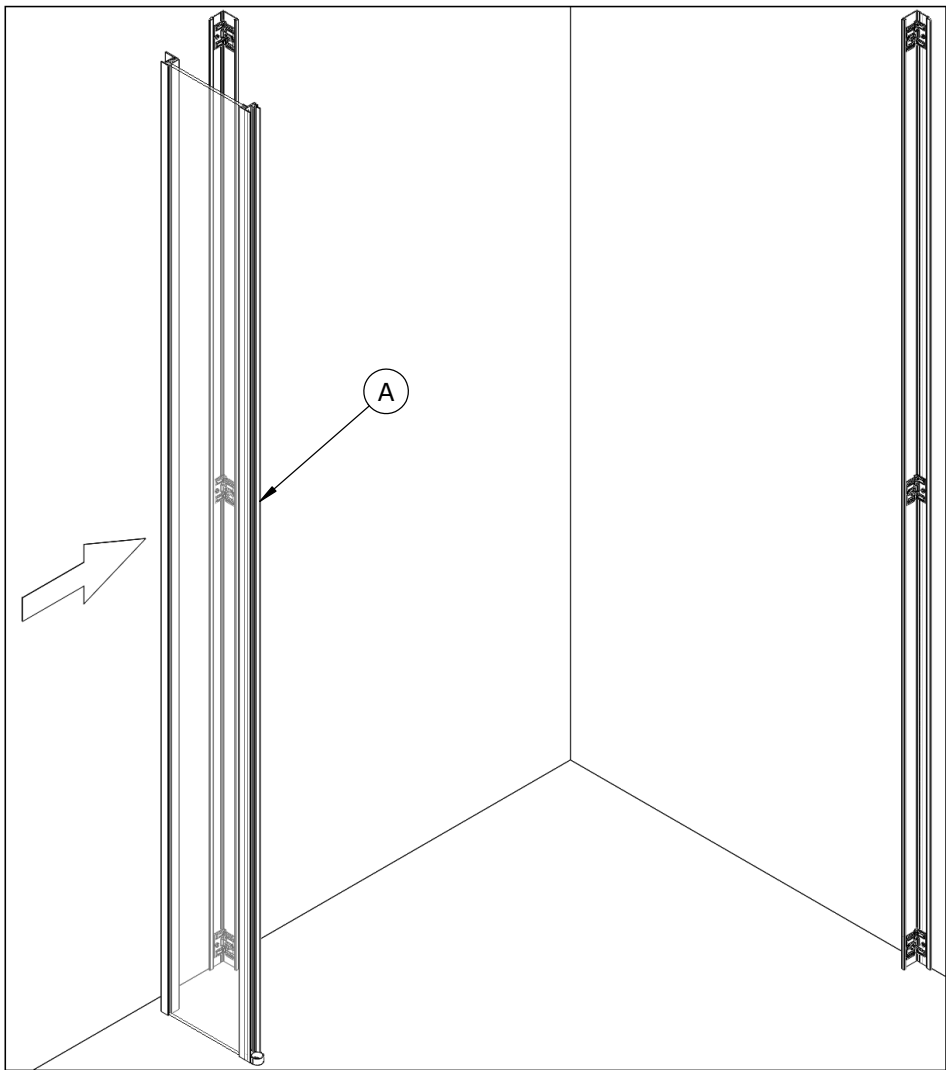

● Ajuster puis serrer ● Fit then tighten



● Regolare e poi serrare

● Stel af en draai vast ● Anpassen dann anziehen

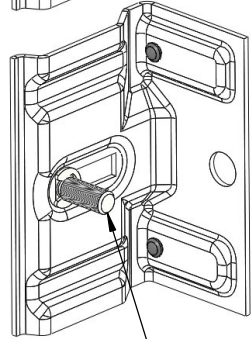
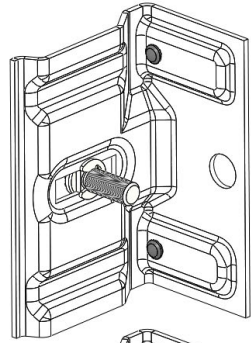

● Si nécessaire, desserrer, régler puis resserrer

● If necessary, loosen, adjust and retighten

● Se necesario, allentare, regolare e stringere

● Draai los, indien nodig, stel af en draai vervolgens weer vast

● Falls erforderlich, lösen, einstellen und wieder festziehen

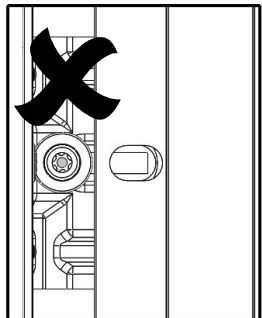
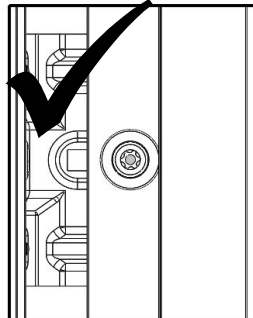
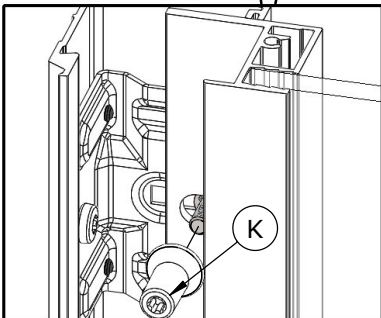
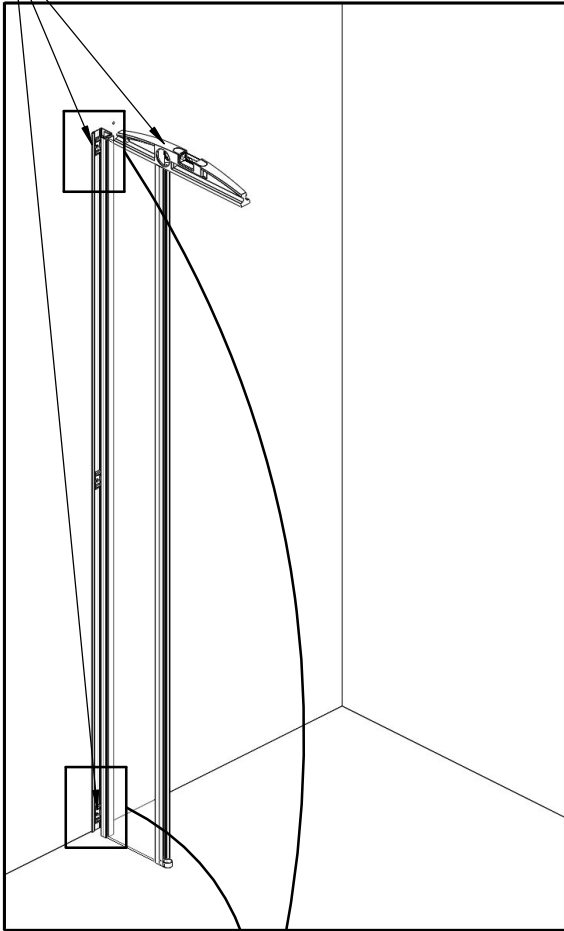

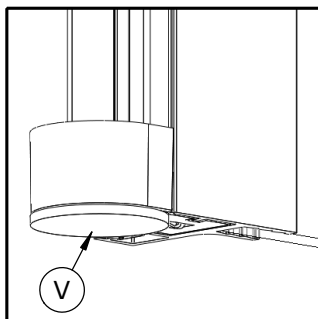
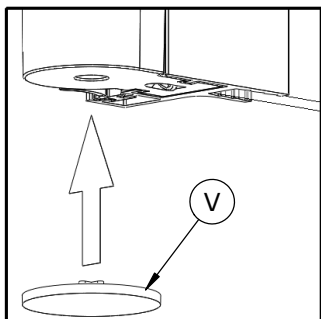
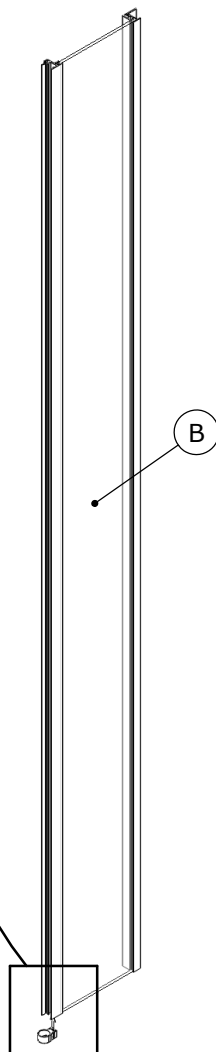
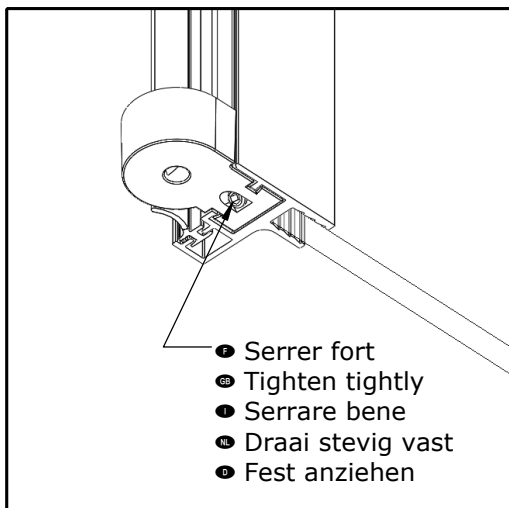
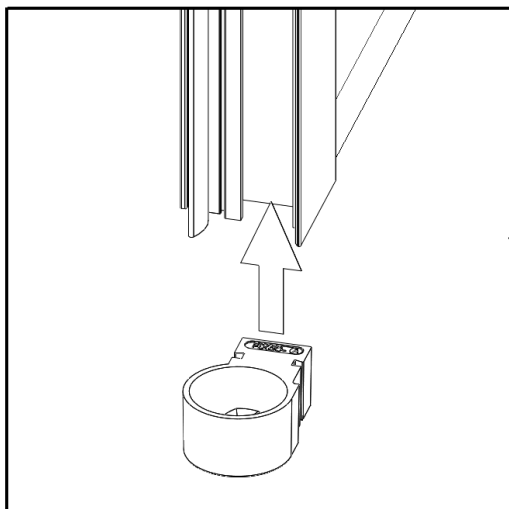

- Ajuster puis serrer ● Fit then tighten
- Regolare e poi serrare
- Stel af en draai vast ● Anpassen dann anziehen

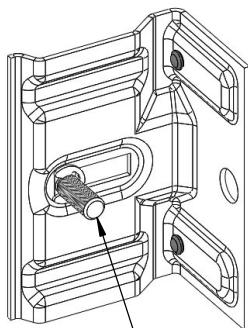
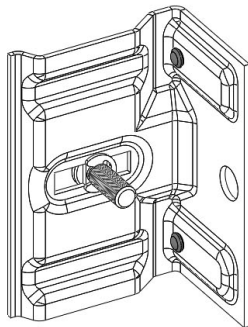
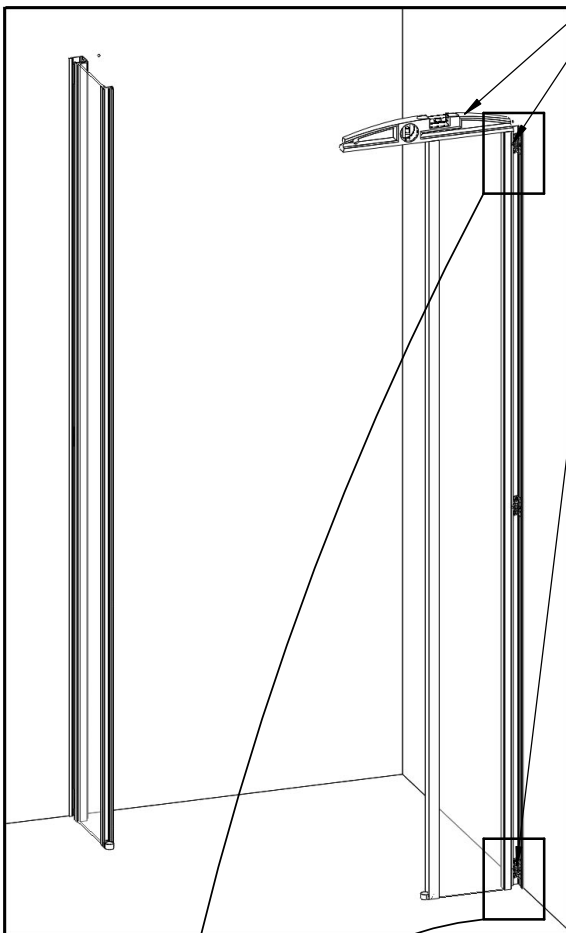

- Si nécessaire, desserrer, régler puis resserrer
- If necessary, loosen, adjust and retighten
- Se necesario, allentare, regular e stringere
- Draai los, indien nodig, stel af en draai vervolgens weer vast
- Falls erforderlich, lösen, einstellen und wieder festziehen

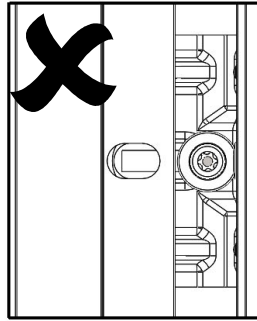
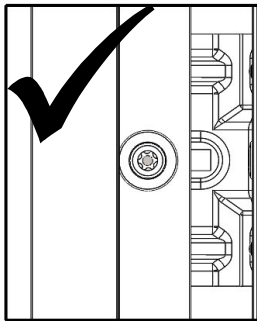
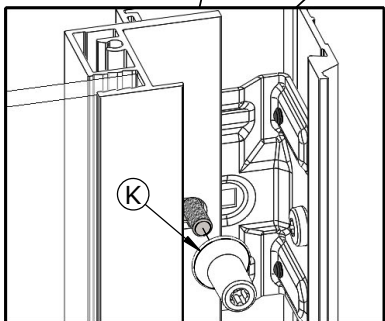

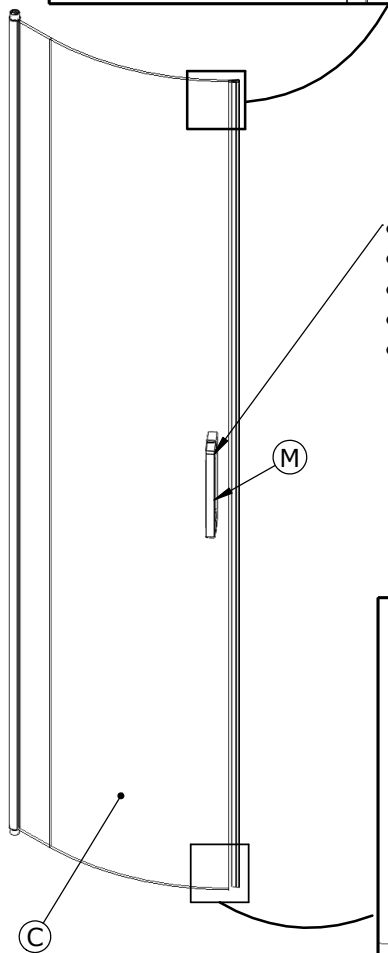
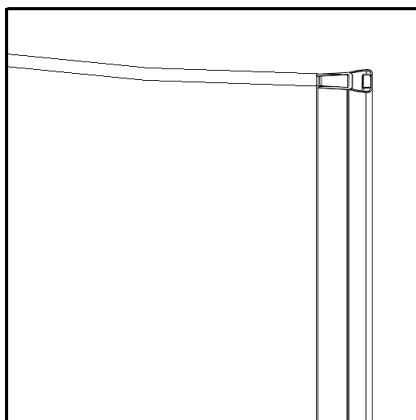
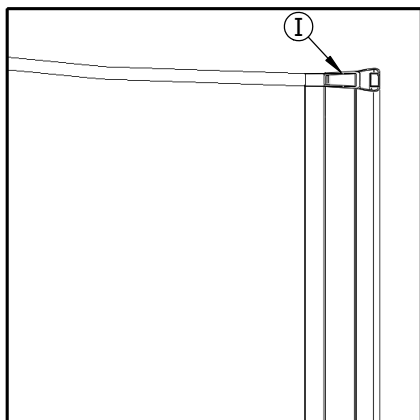

- Voir notice concernée
- See installation instructions required
- Vedere manuale appropriato
- Zie de bijbehorende montagehandleiding
- Siehe betreffende Anleitung

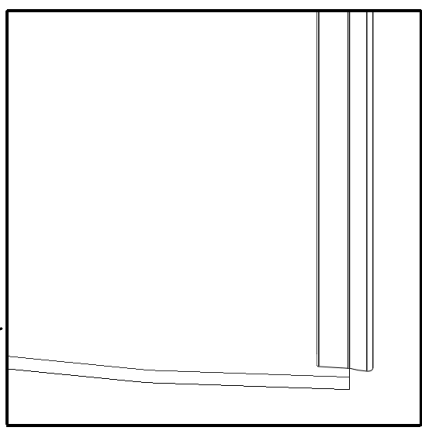

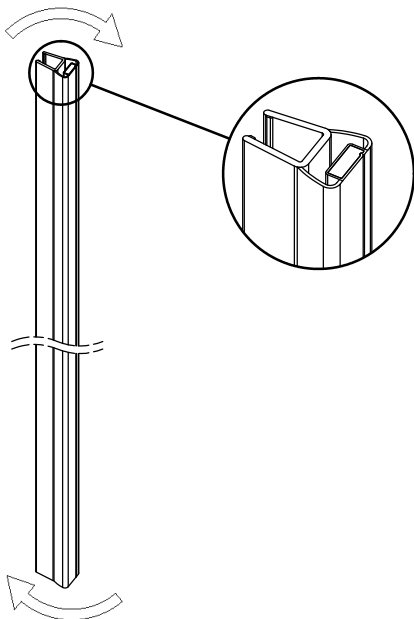
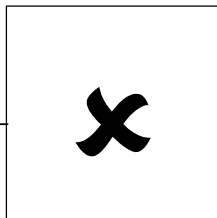
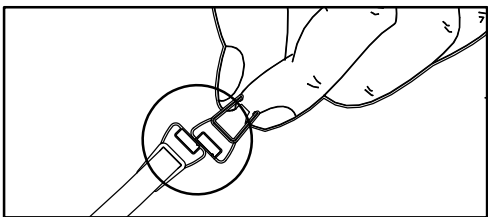
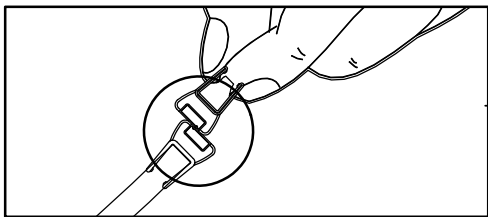
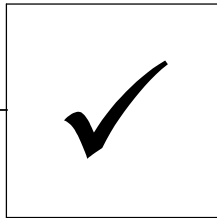
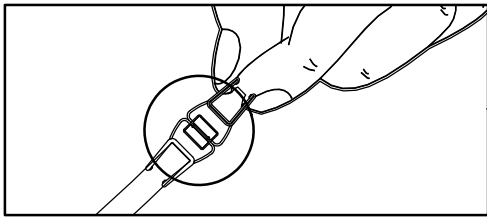

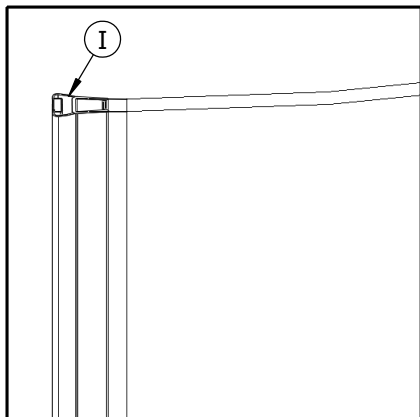
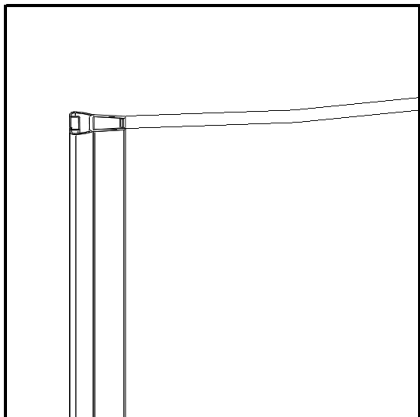

- Voir notice concernée
- See installation instructions required
- Vedere manuale appropriato
- Zie de bijbehorende montagehandleiding
- Siehe betreffende Anleitung

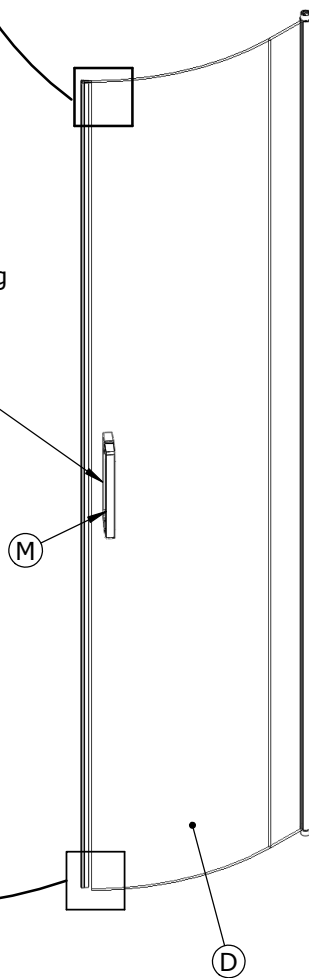
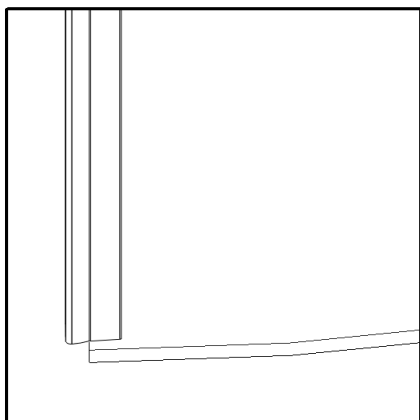

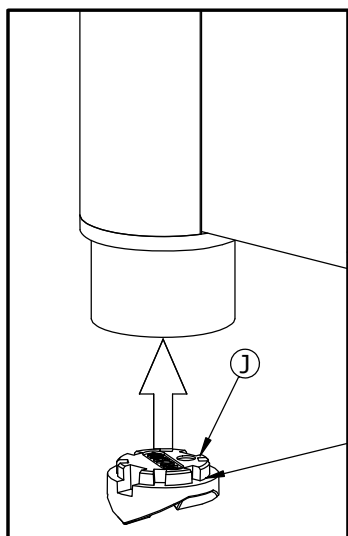
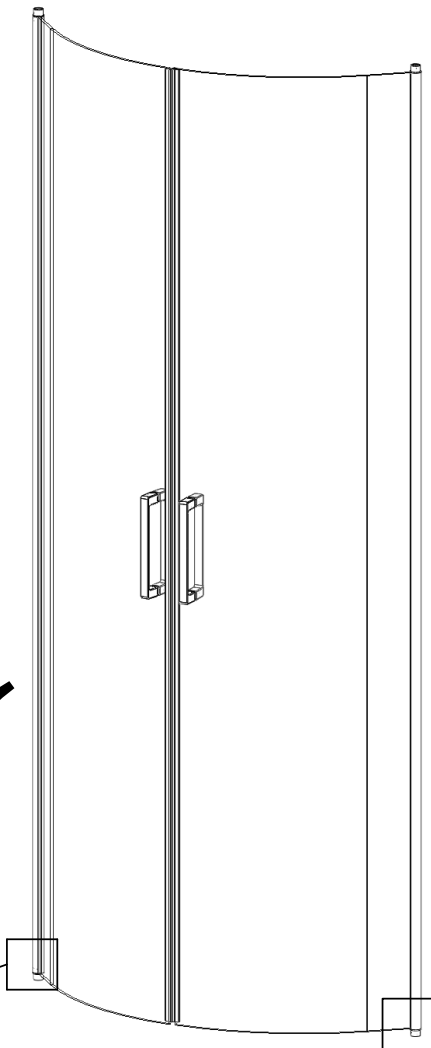
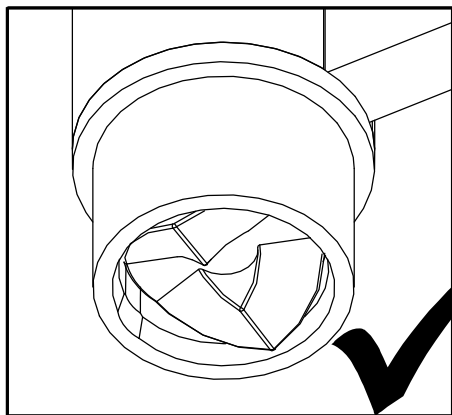
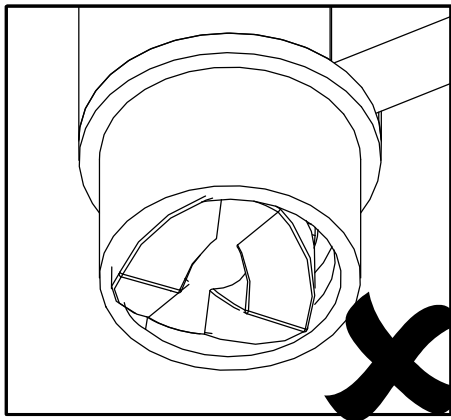

X2



- Mettre en partie basse
- Put in the lower part
- Mettere nella parte inferiore
- Plaats in het onderste deel
- Setzen Sie in den unteren Teil.

- Réglages des portes ● Adjusting the doors ● regolazione porte
- Deuren afstellen ● Ausrichten und Einstellen der Tür

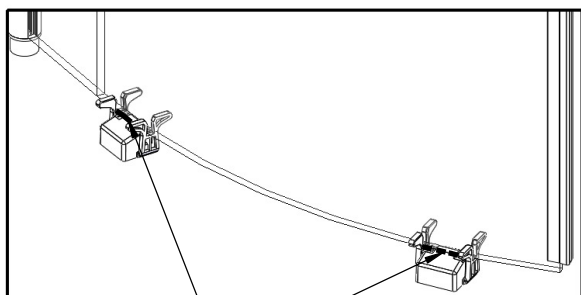
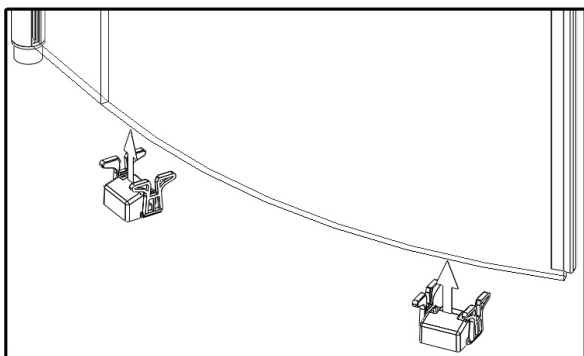
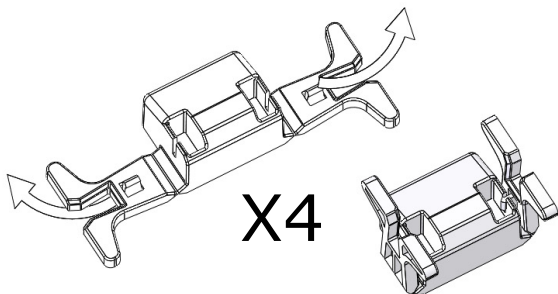

- F Mettre en contact
- GB Put in contact
- I Mettere in contatto
- NL Mensen in contact te brengen
- D Kontakte knüpfen

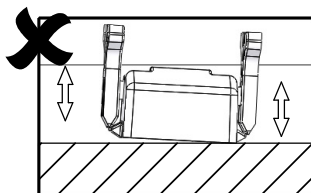
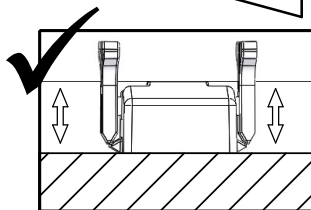
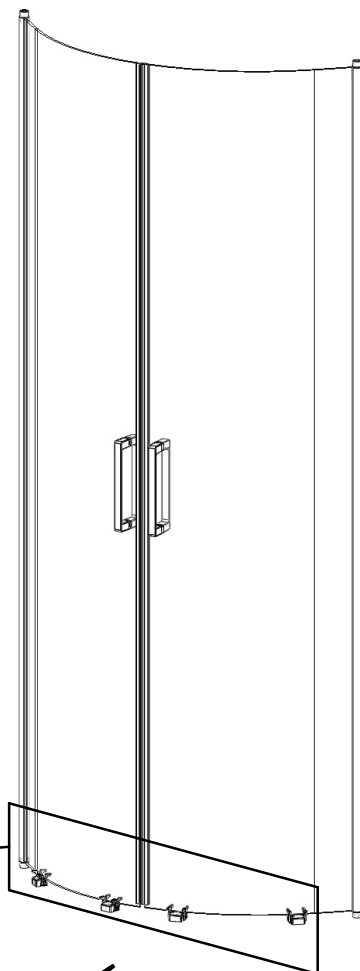
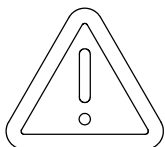

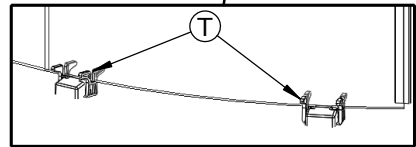
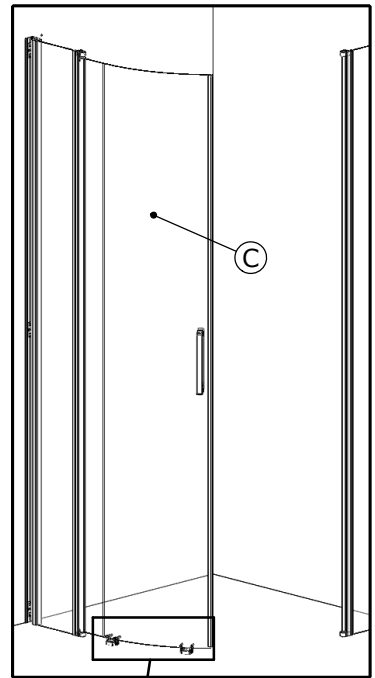
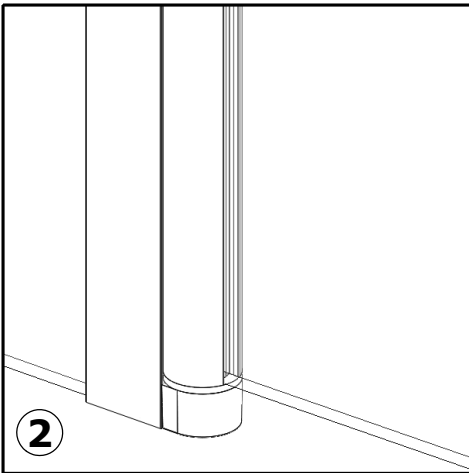
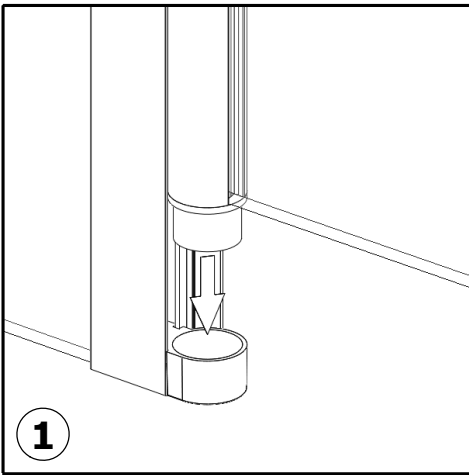

- Affleurant
- Align
- A filo
- Zijkanten niet laten uitsteken
- Bündig auszurichtende oberseiten

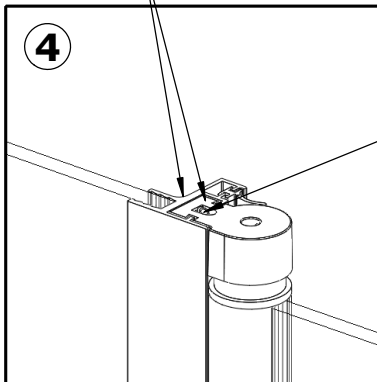
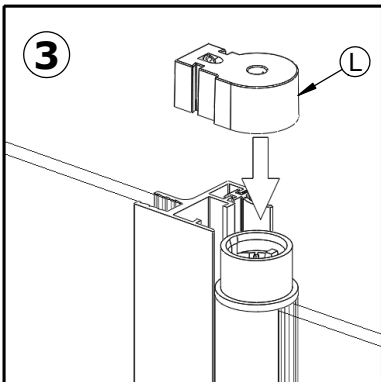

- Serrer fort
- Tighten tightly
- Serrare bene
- Draai stevig vast
- Fest anziehen

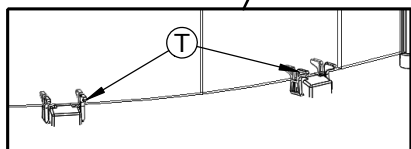
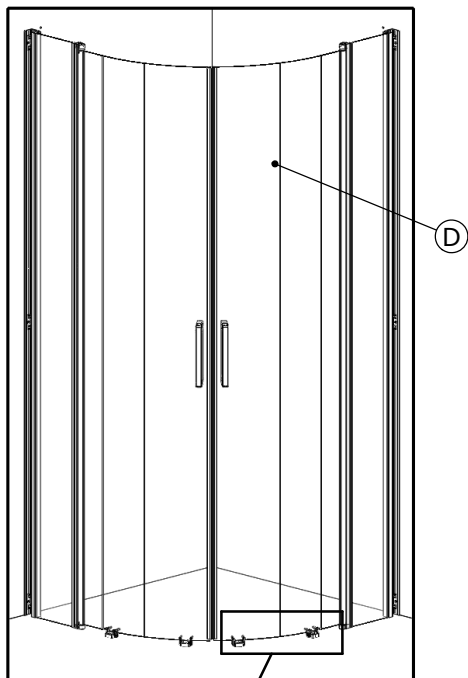

- Affleurant
- Align
- A filo
- Zijkanten niet laten uitsteken
- Bündig auszurichtende oberseiten

- Serrer fort
- Tighten tightly
- Serrare bene
- Draai stevig vast
- Fest anziehen

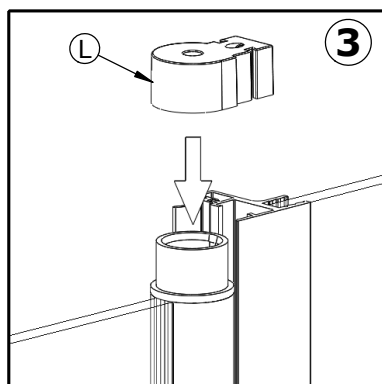
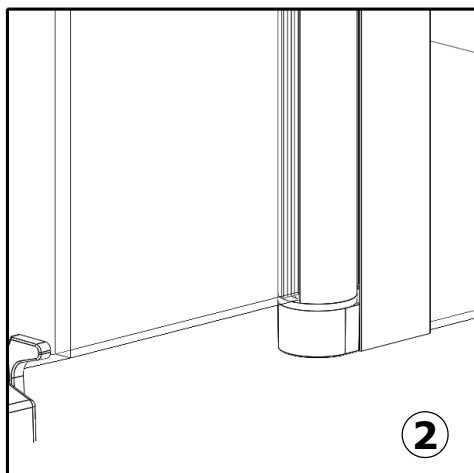
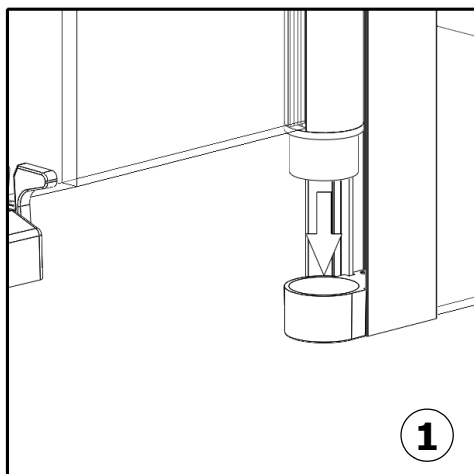
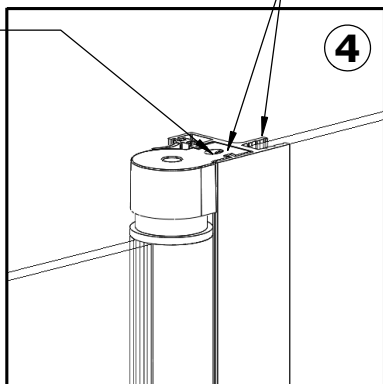

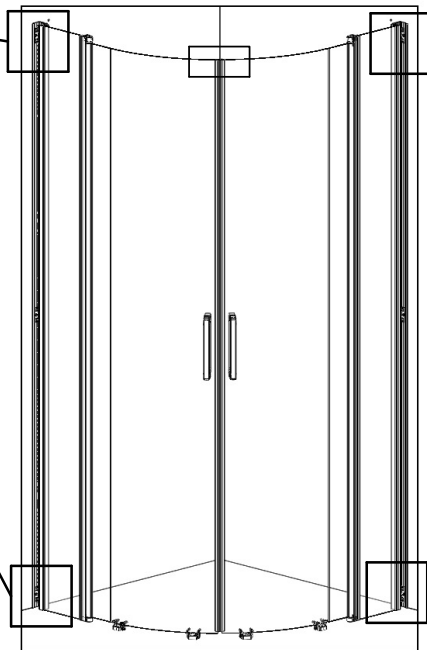
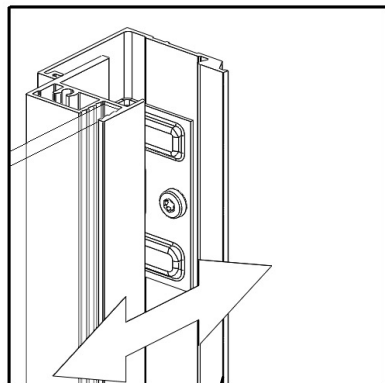
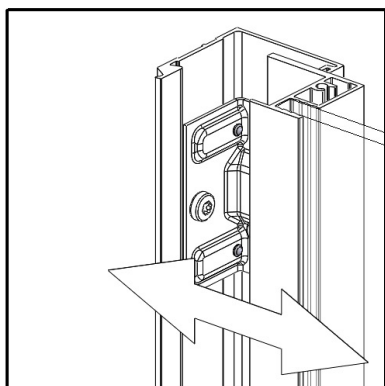
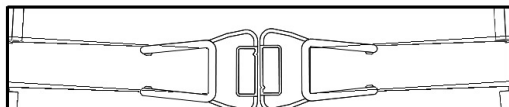

- F Ajuster si necessaire, puis resserrer
- GB Adjust if necessary, then tighten again
- I regolare se necessario poi serrare
- NL Stel af indien nodig, en draai dan vast
- D Gegebenenfalls nachjustieren, dann nachziehen

R/U

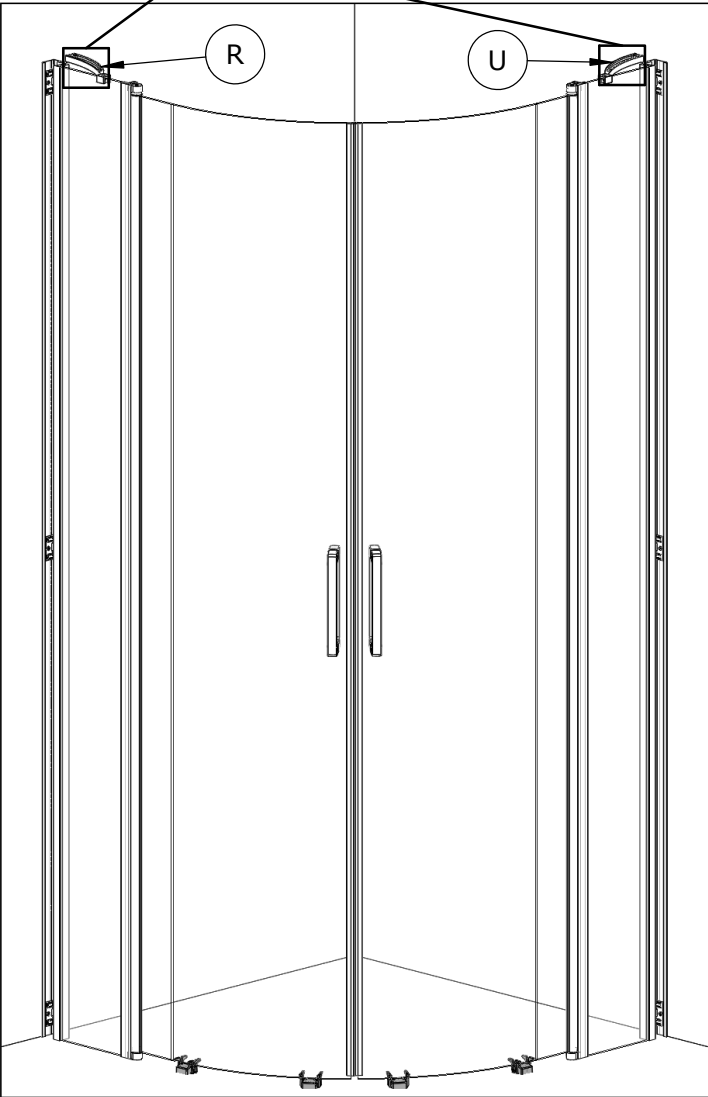
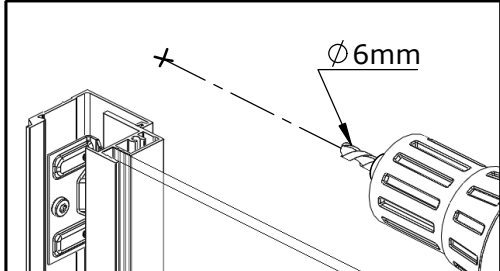
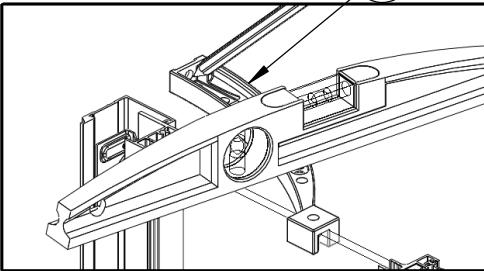

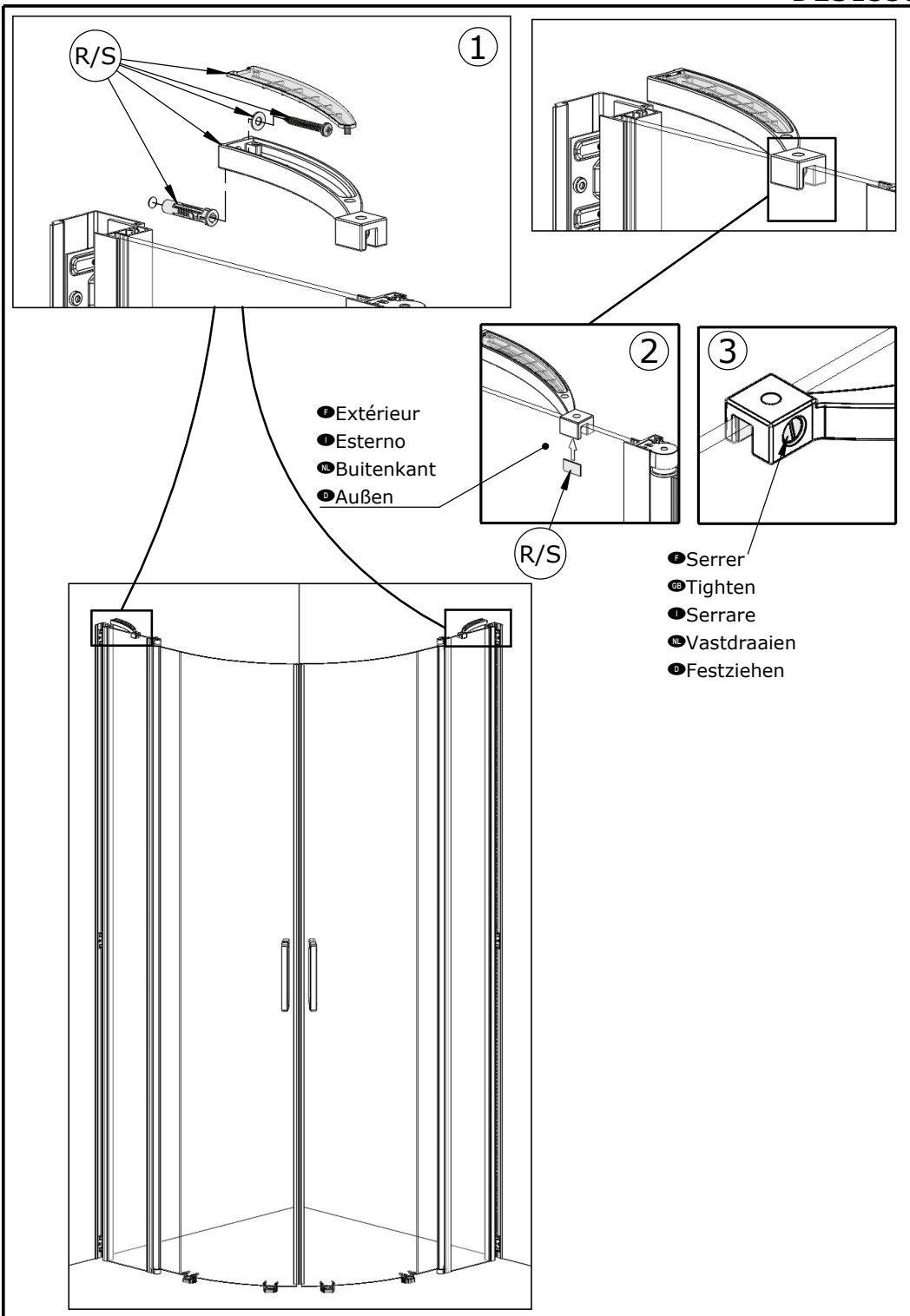

- F Ajuster puis serrer
- GB Fit then tighten
- I Regolare e poi serrare
- NL Stel af en draai vast
- D Anpassen dann anziehen

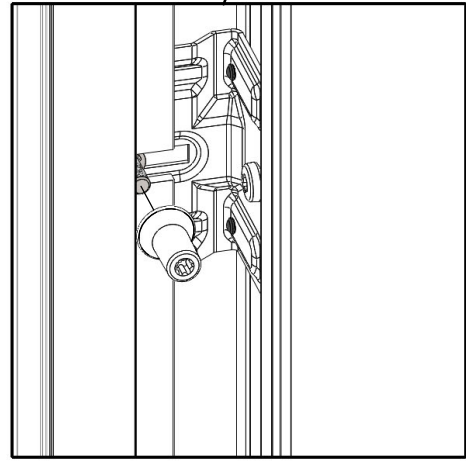
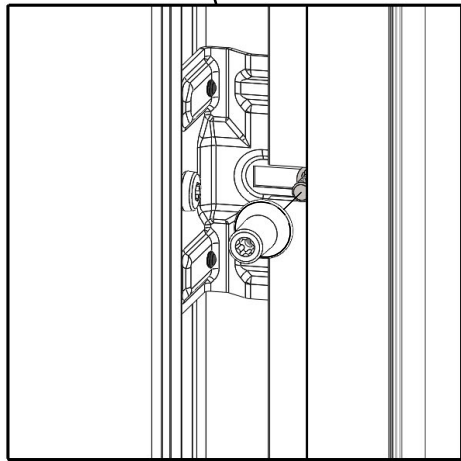
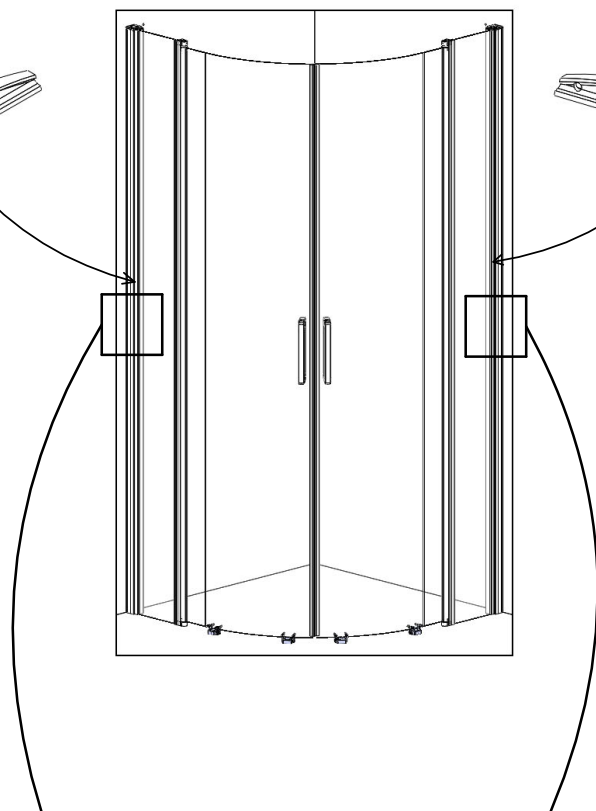
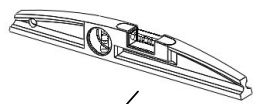
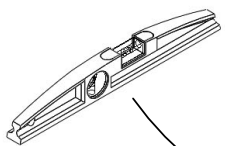
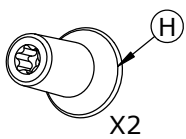

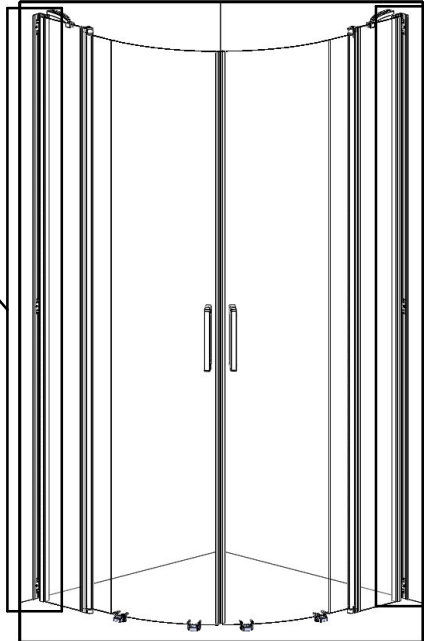
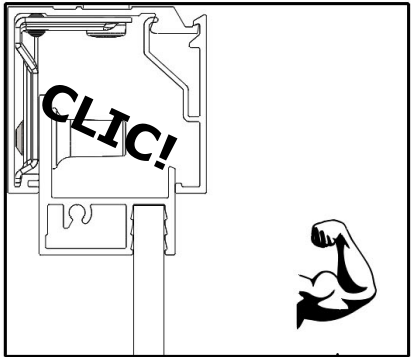
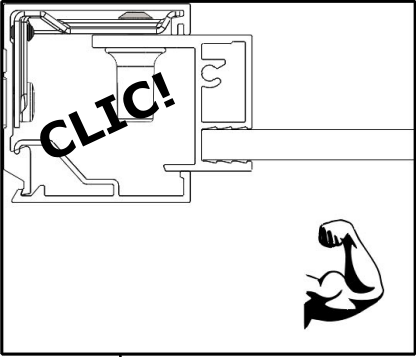
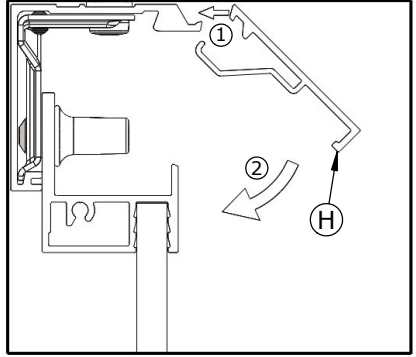
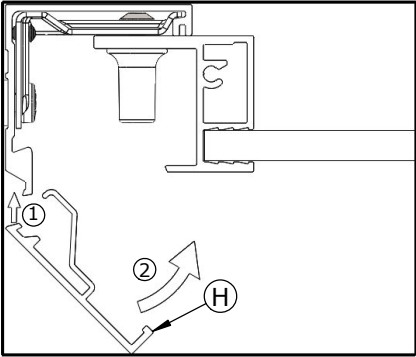

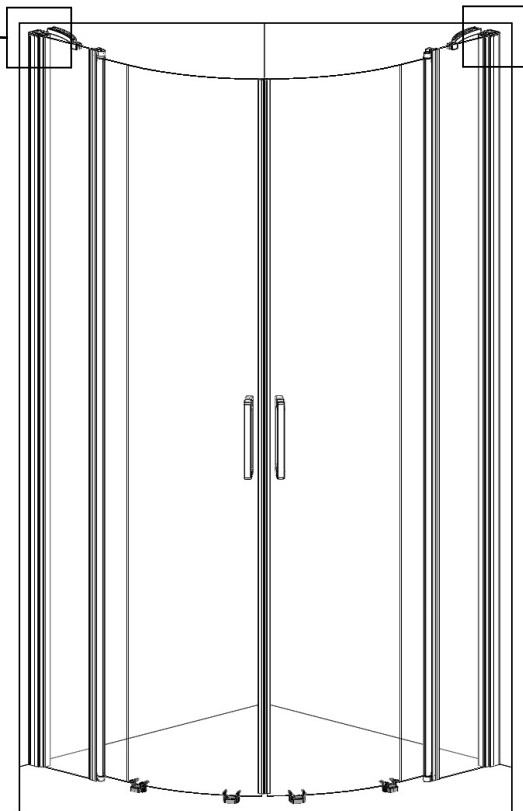
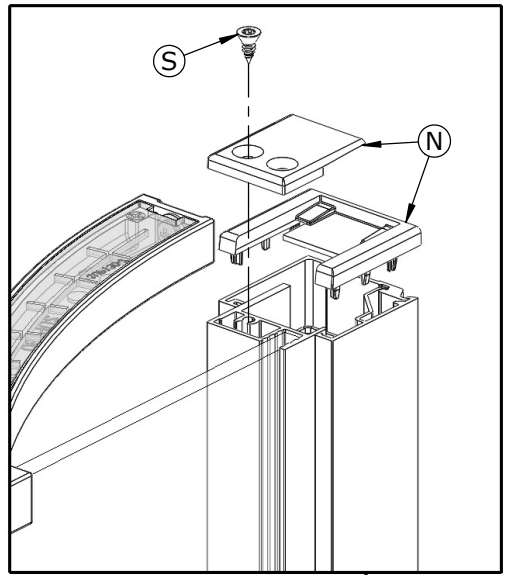
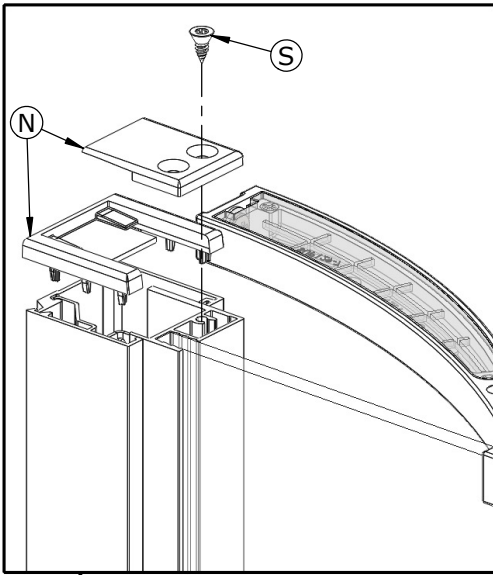

- Retirer (T) ● Remove (T) ● Togliere (T)  
● Verwijderen (T) ● Entfernen (T)

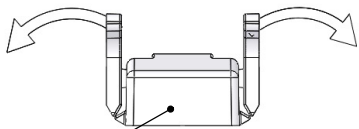

T

X4

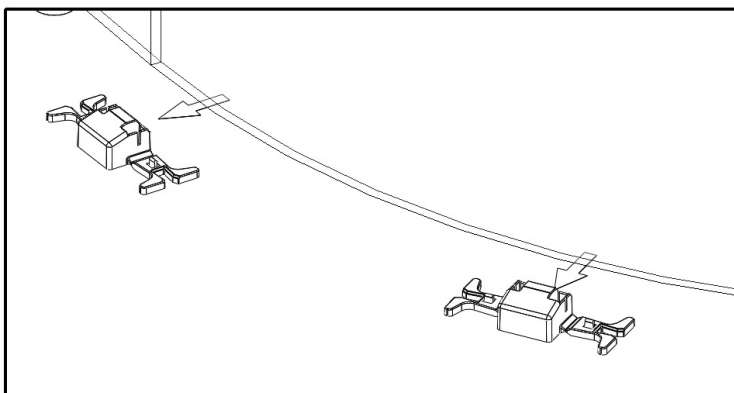
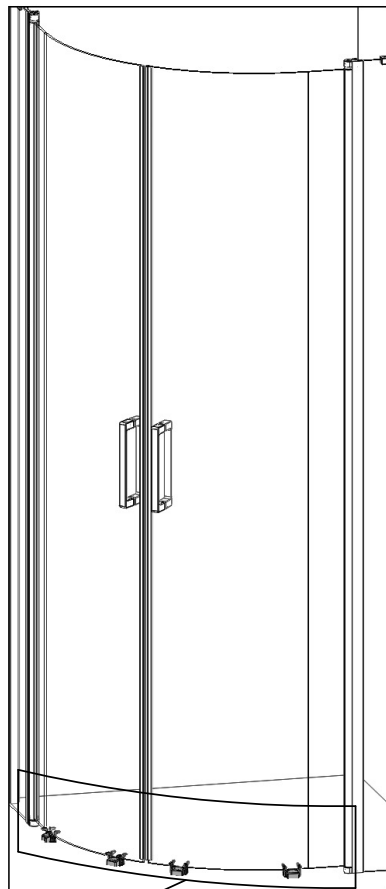
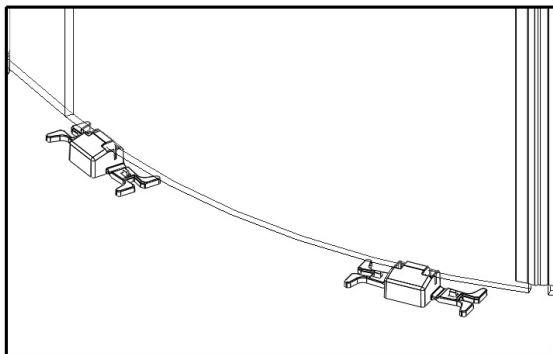

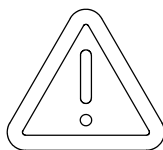
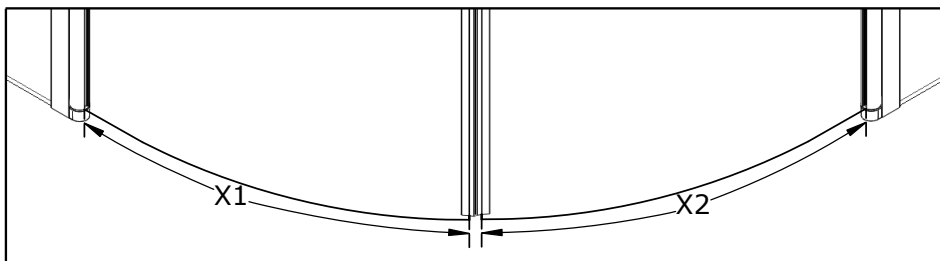

● Intérieur ● Interior  
 ● Interno  
 ● Binnenzijde ● Innen

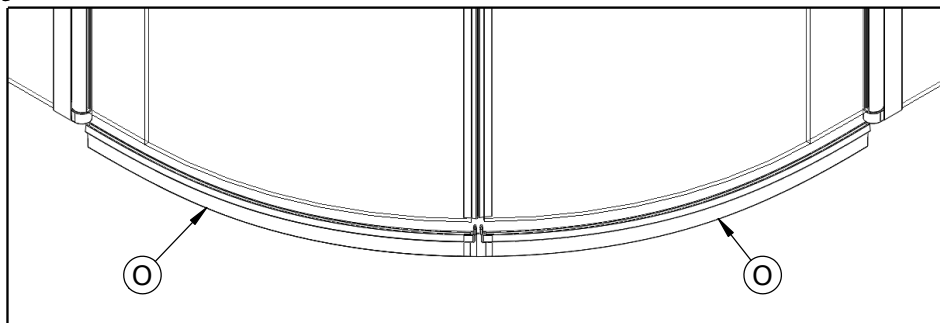
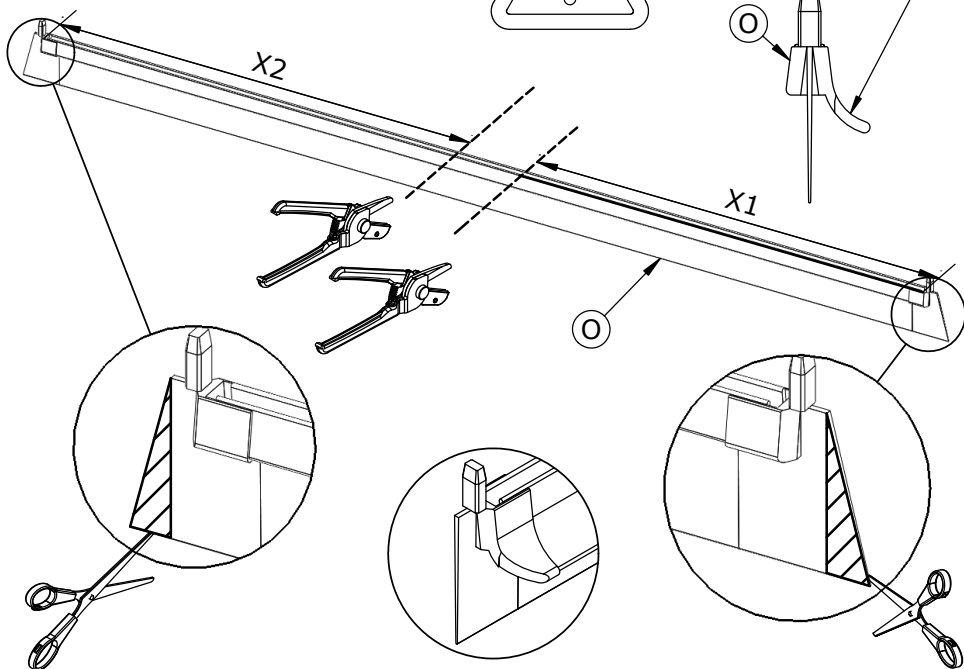

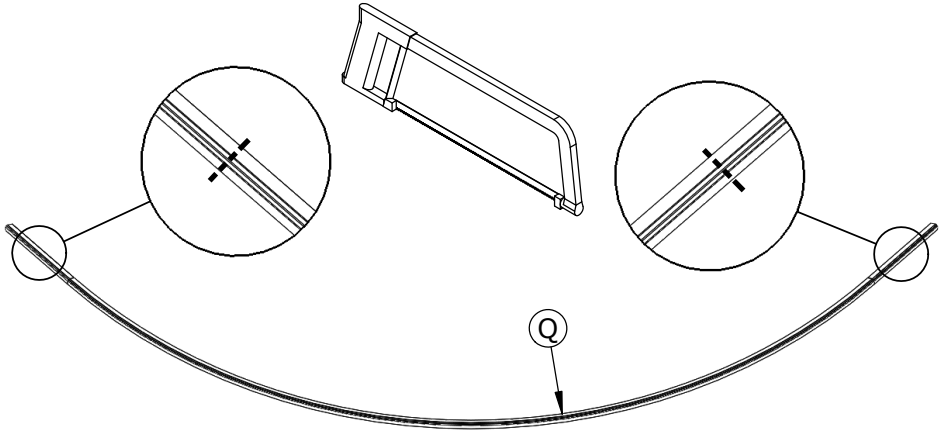
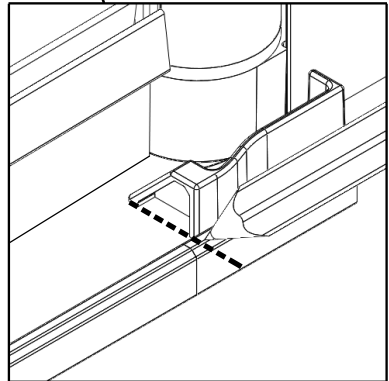
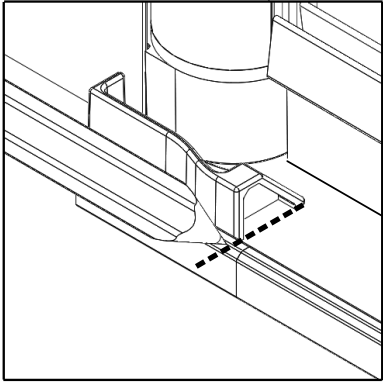
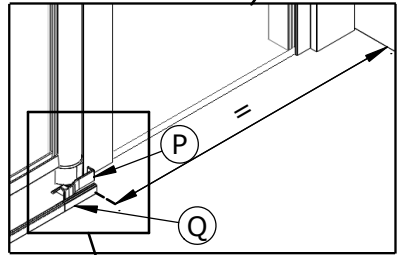
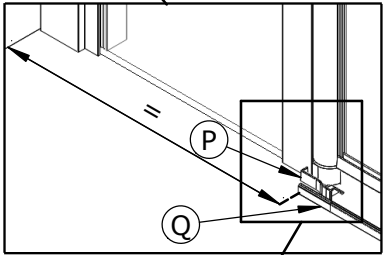
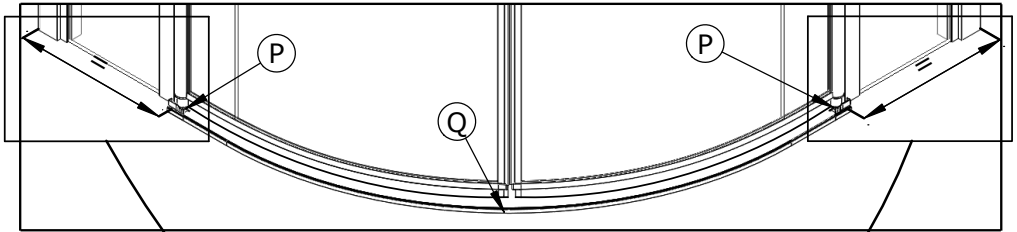

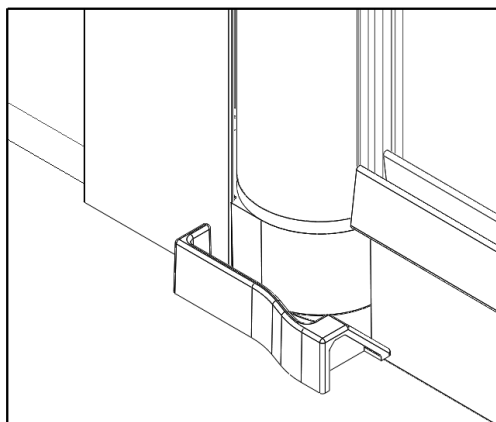
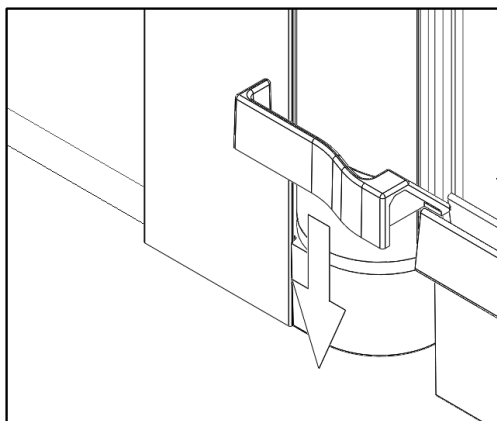
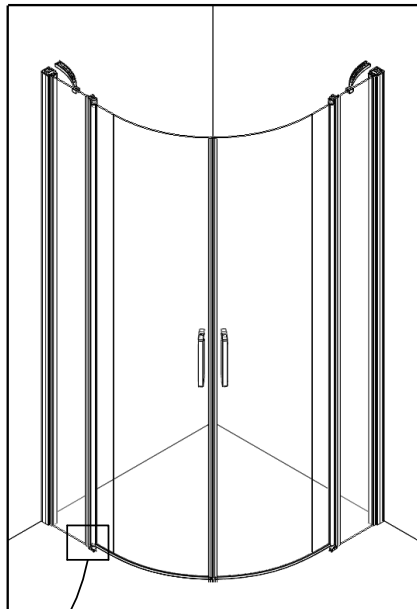
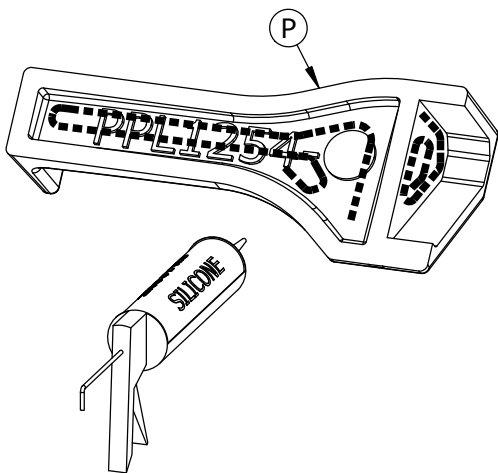

● Extérieur ● Outside ● Esterno  
 ● Buitenkant ● Außen

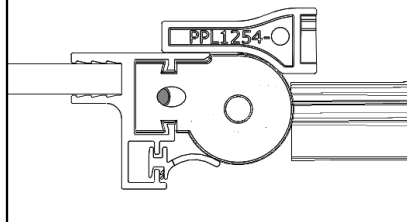

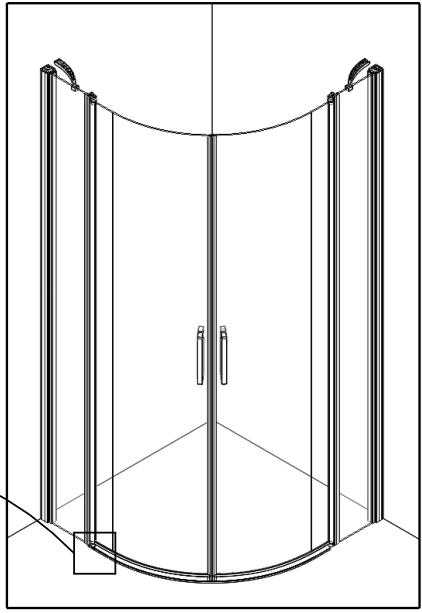
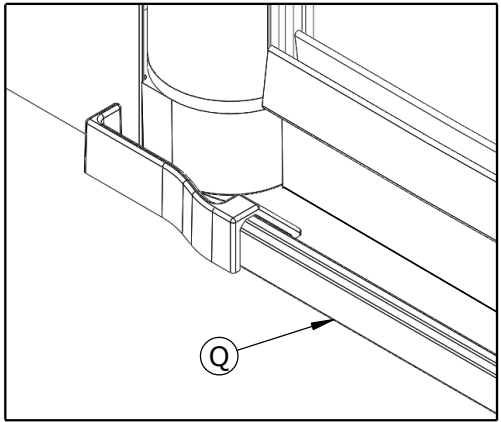
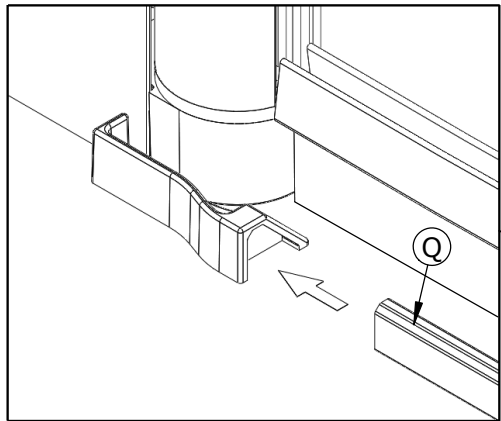
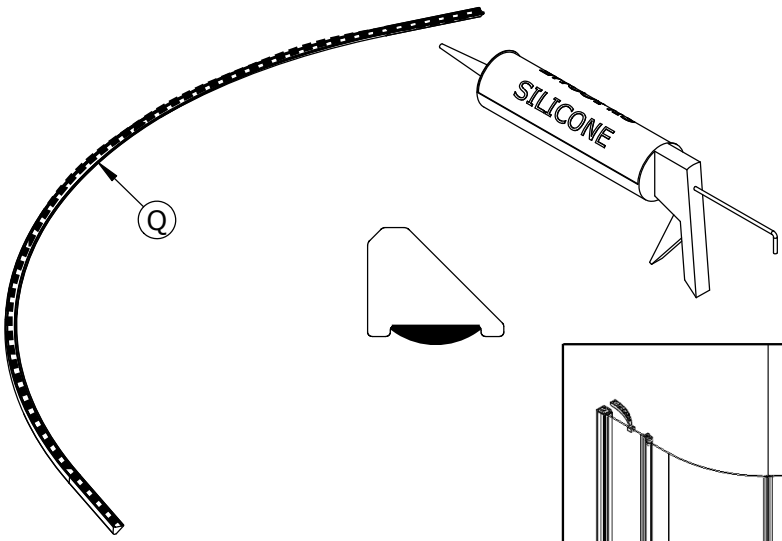

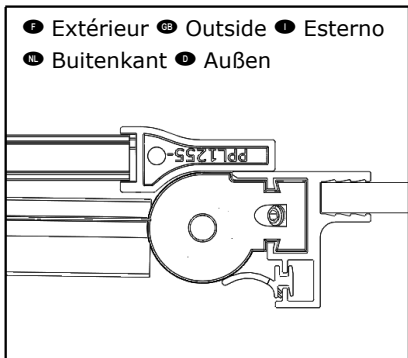
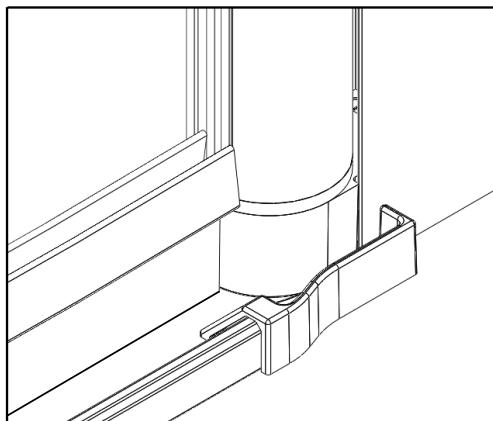
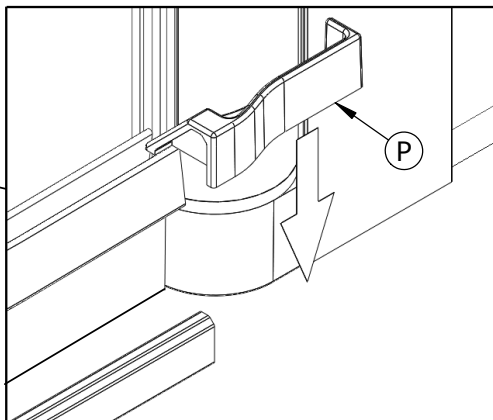
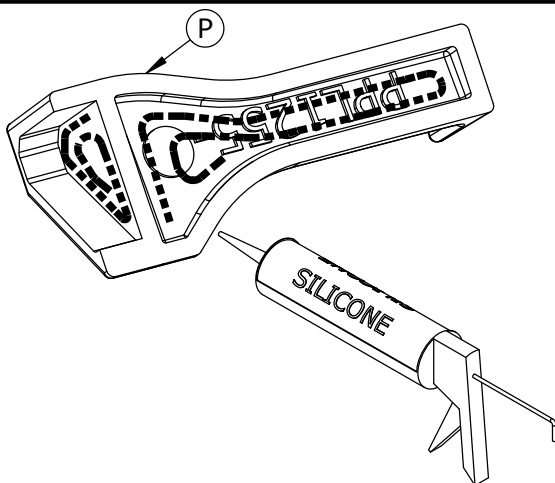
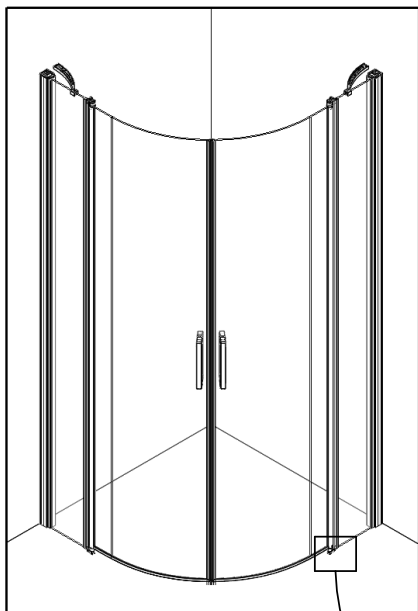

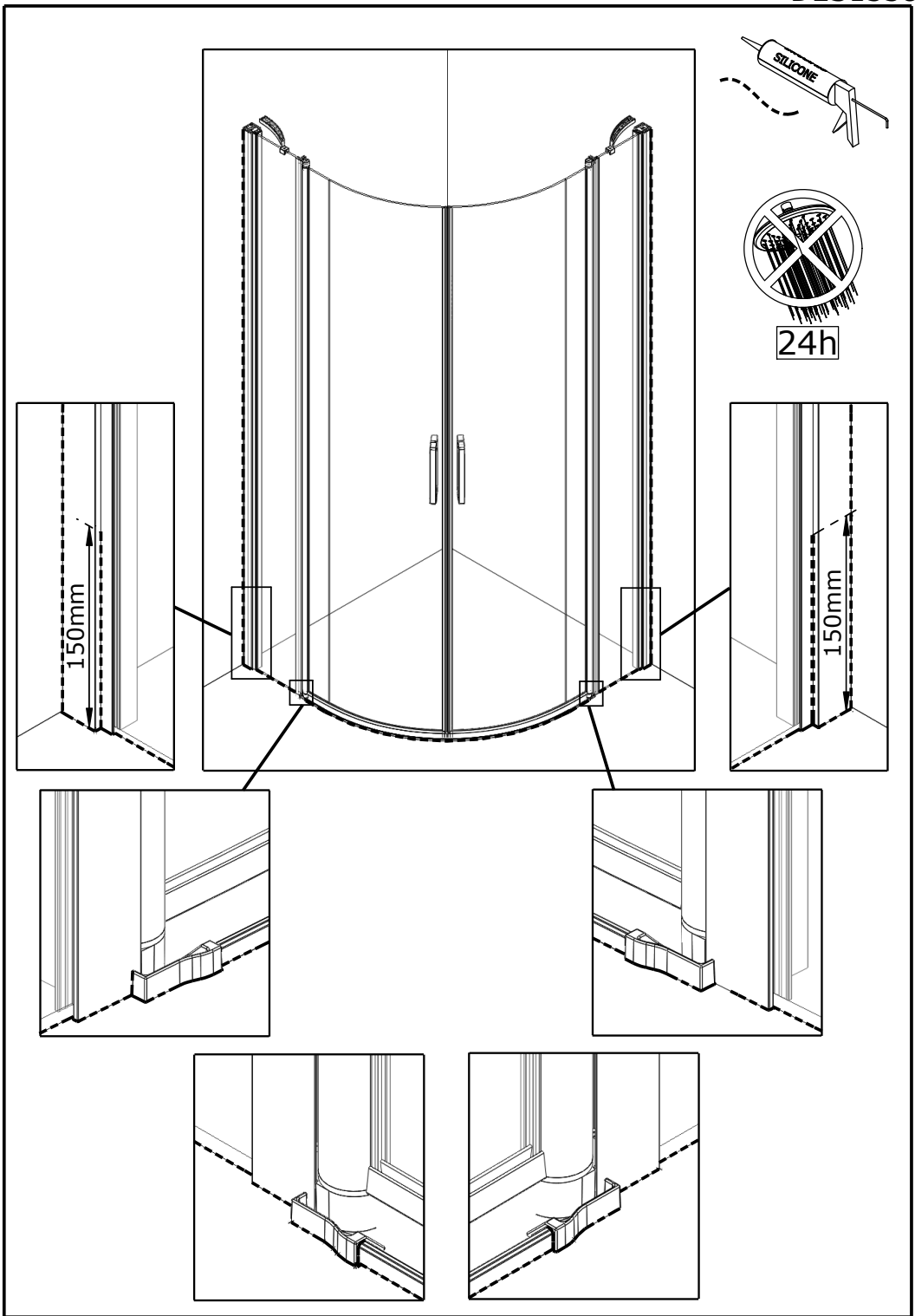



**SAV**  
**SERVICE HELPLINES**  
**ASSISTENZA POST-VENTITA**  
**SERVICIO POSTVENTA**

**FRANCE**

02 40 21 29 45

**UK**

020 8842 0033

**IRELAND**

04697 33102

**DEUTSCHLAND**

+49 (0) 6074 / 30928 0

**ITALIA**

(0382) 6181

**OSTEREICH**

+43 1 710 60 70

**SCHWEIZ**

(01) 748 17 44

**ESPAÑA**

93 544 60 76

**NEDERLAND**

+31 475 487 100

**BELGIE**

+31 475 487 100

**BELGIQUE**

+31 475 487 100

**РОССИЯ**

963 19 40, 773 67 22



AQUAPRODUCTION, Site industriel,  
 F - 44680 Chaumes-en-Retz

18

**EN 14428**

Paroi de douche, fabriquée en verre de silicate  
 sodo-calcique de sécurité trempé thermiquement

Aptitude au nettoyage : réussite

Résistance à l'impact/propriétés de fragmentation : réussite

Durabilité : réussite