

● F Notice de montage ● GB Installation instructions
● I Istruzioni di montaggio
● NL Montage-instructies ● D Montageanleitung

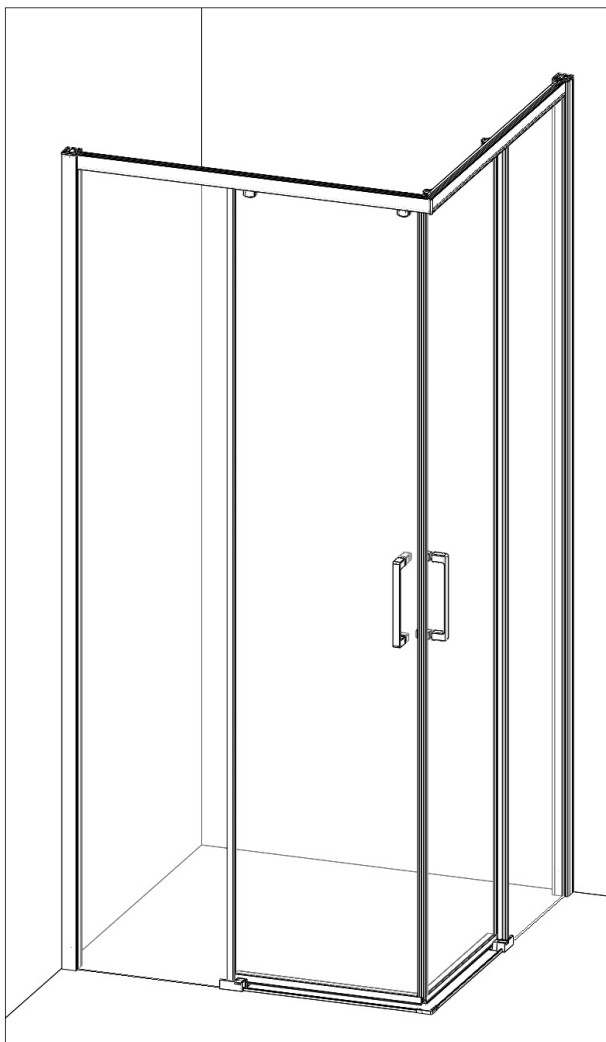







Notre service technique est
à votre écoute aux numéros
qui sont au dos de cette
notice d'installation

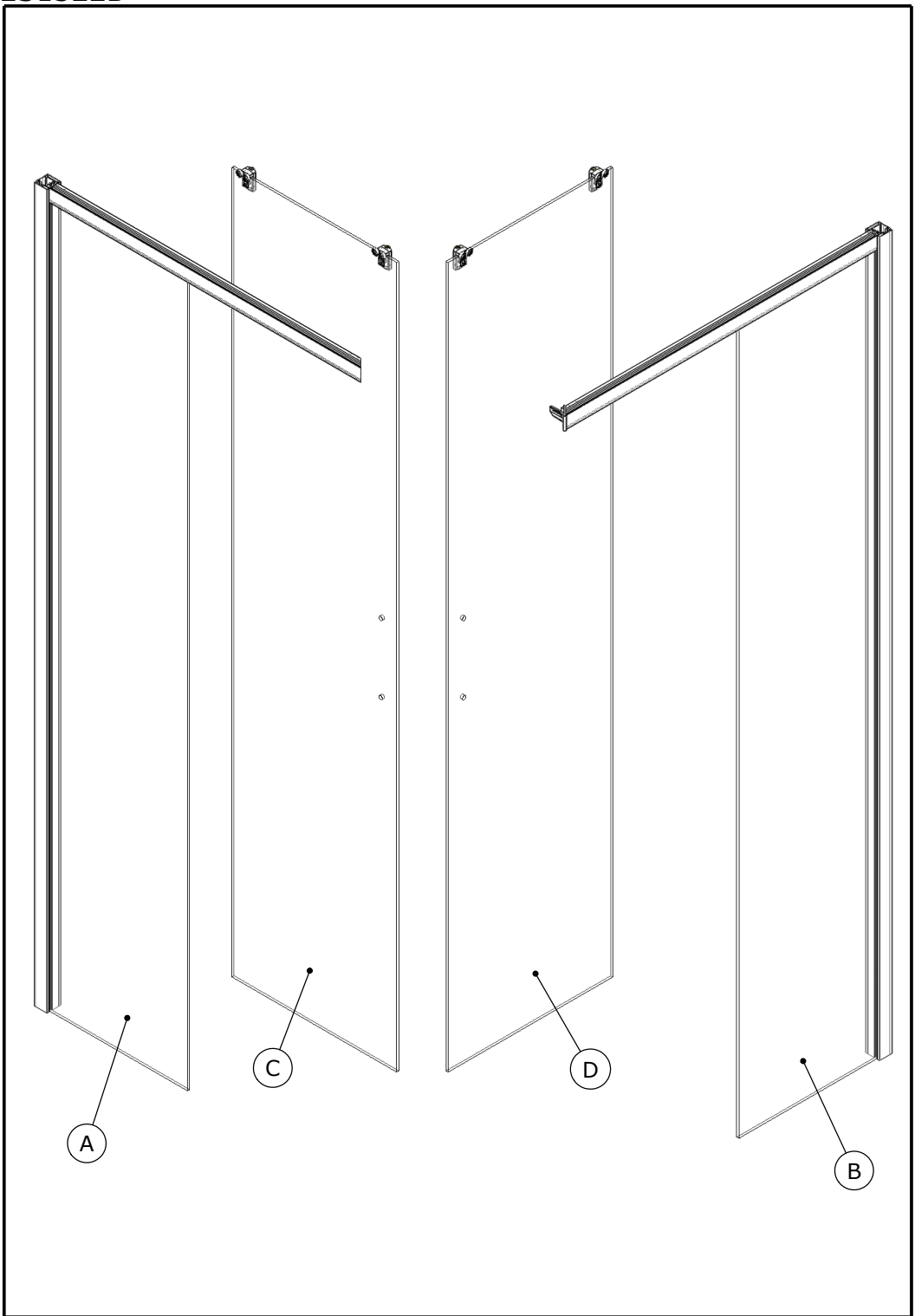

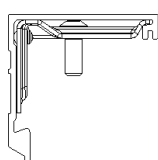
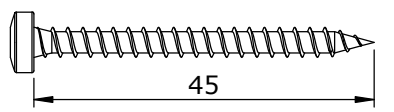
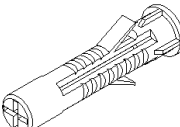
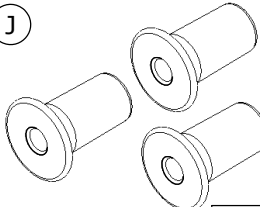
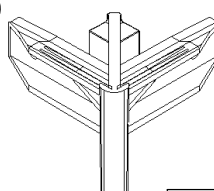
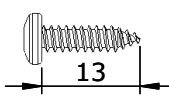
- F Attention aux étapes :
- GB Check installation steps :
- I Attenzione ai passi :
- NL Aandacht voor de stappen :
- D Achtung vor den Schritten :

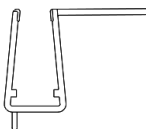
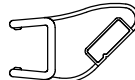
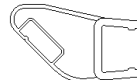
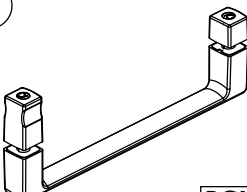
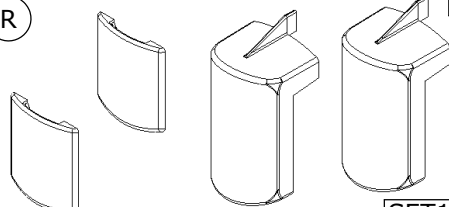
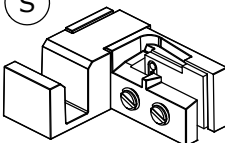
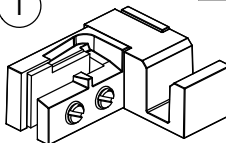
P. 5 - 11 - 26

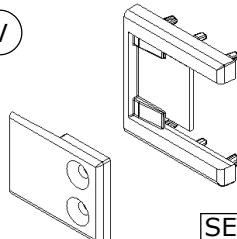

<p>G x2</p>  <p style="text-align: right;">6268</p>	<p>H Ø4 x6</p>  <p style="text-align: right;">VIS231</p>	
<p>I x6</p>  <p style="text-align: right;">CHE02</p>	<p>J x2</p>  <p style="text-align: right;">SET134</p>	<p>K x1</p>  <p style="text-align: right;">PPL1244</p>
<p>L Ø3.5 x4</p>  <p style="text-align: right;">VIS217</p>	<p>M x2</p>  <p>Lg=1966mm J787</p>	<p>N x2</p>  <p>Lg=1946mm J781</p>
<p>O x1</p>  <p>Lg=1949mm AI172</p>	<p>P x1</p>  <p>Lg=1949mm AI173</p>	<p>Q x2</p>  <p style="text-align: right;">PGN50</p>
<p>R x2</p>  <p style="text-align: right;">SET135</p>	<p>S x1</p>  <p style="text-align: right;">SET130</p>	<p>T x1</p>  <p style="text-align: right;">SET131</p>
<p>U x2</p>  <p style="text-align: right;">6270</p>	<p>V x2</p>  <p style="text-align: right;">SET137</p>	<p>W Ø3.5 x2</p>  <p style="text-align: right;">VIS261</p>

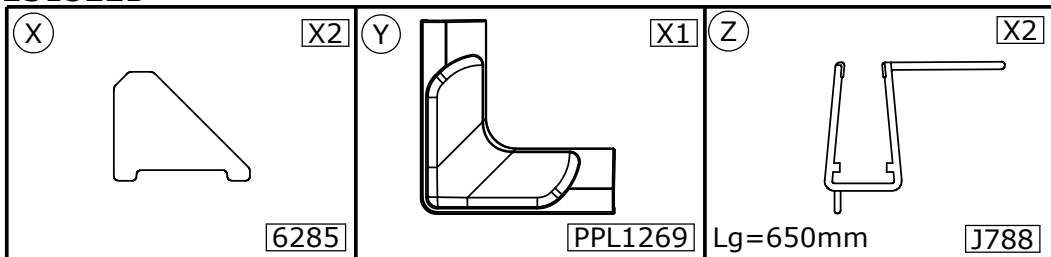

- Les quantités données sont les quantités utiles au montage. les sachets fournis contiennent des pièces supplémentaires.
 - The quantities given are what are required for the installation. There may be some surplus in the package provide.
- Las cantidades indicadas son las cantidades necesarias para el montaje. Las bolsitas incluidas contienen piezas suplementarias.
 - Le quantità fornite sono le quantità necessarie al montaggio. I sacchetti forniti contengono pezzi supplementari.
 - De aangegeven aantallen zijn vereist voor de montage. De verpakking bevat extra onderdelen.
 - Die Mengenangaben beziehen sich auf die für die Montage nötigen Teile. Eventuell weitere beige packte Teile ignorieren.

•Outillage nécessaire•Tools required

•Attrezzatura necessaria•Benodigde gereedschap•Werkzeuge erforderlich

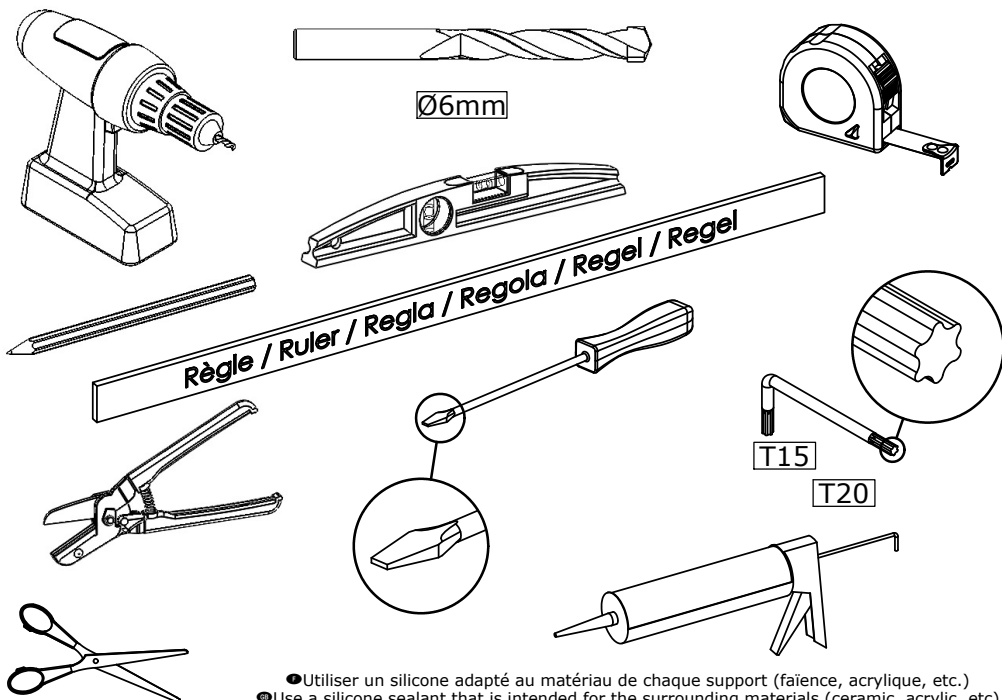

- Utiliser un silicone adapté au matériau de chaque support (faïence, acrylique, etc.)
- Use a silicone sealant that is intended for the surrounding materials (ceramic, acrylic, etc.)
- Utilizzare un silicone adatto a qualsiasi materiale (ceramica, acrilico, ecc.)
- Gebruik siliconenkit die geschikt is voor iedere ondergrond (tegelwerk, acryl, etc.)
- Für das jeweilige Trägermaterial (Stein, Acryl usw.) geeignetes Silikon verwenden.



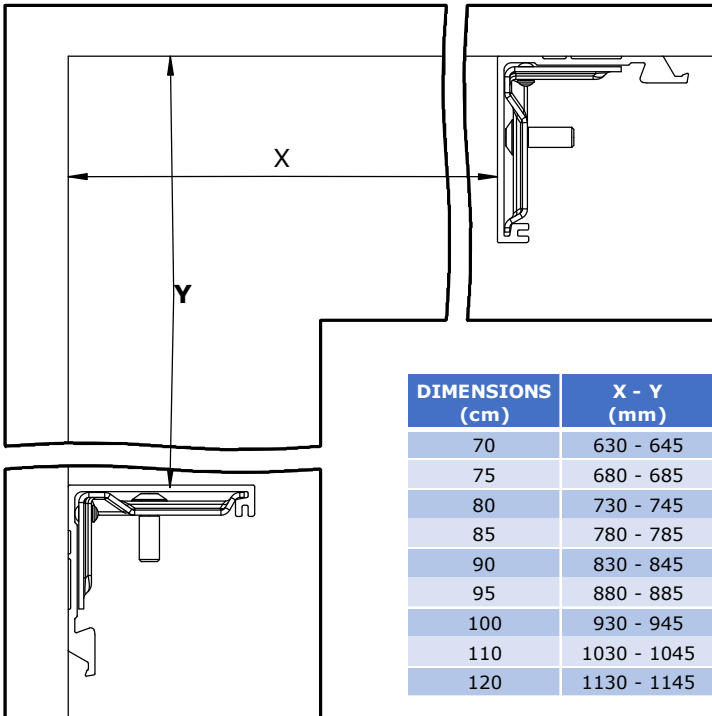
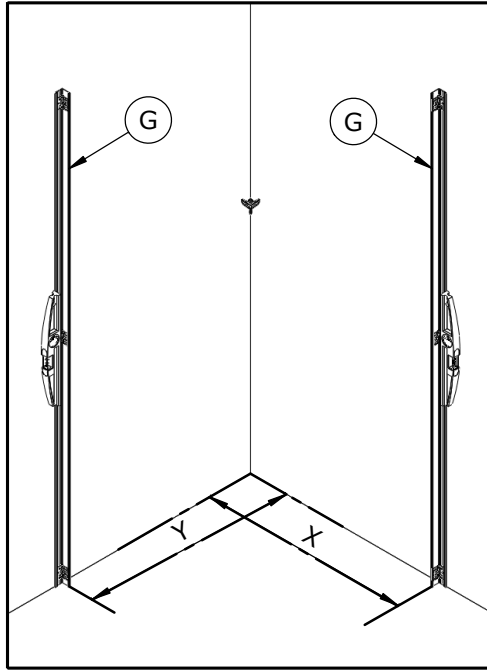

DIMENSIONS (cm)	X - Y (mm)
70	630 - 645
75	680 - 685
80	730 - 745
85	780 - 785
90	830 - 845
95	880 - 885
100	930 - 945
110	1030 - 1045
120	1130 - 1145

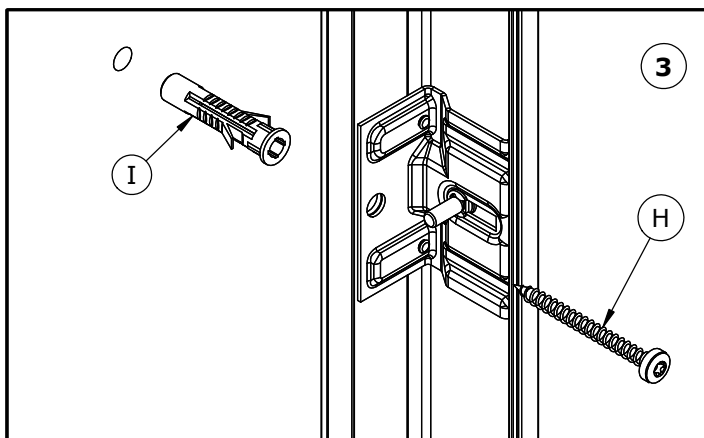
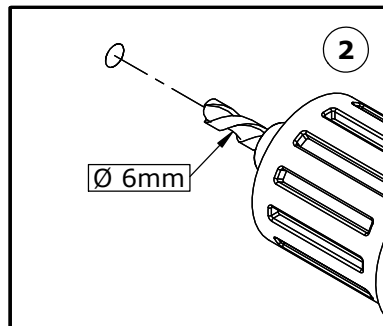
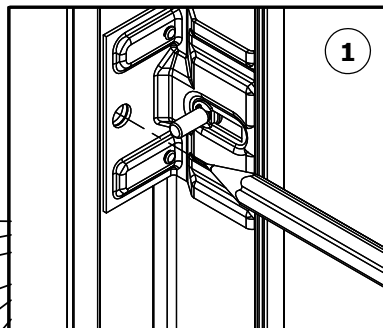
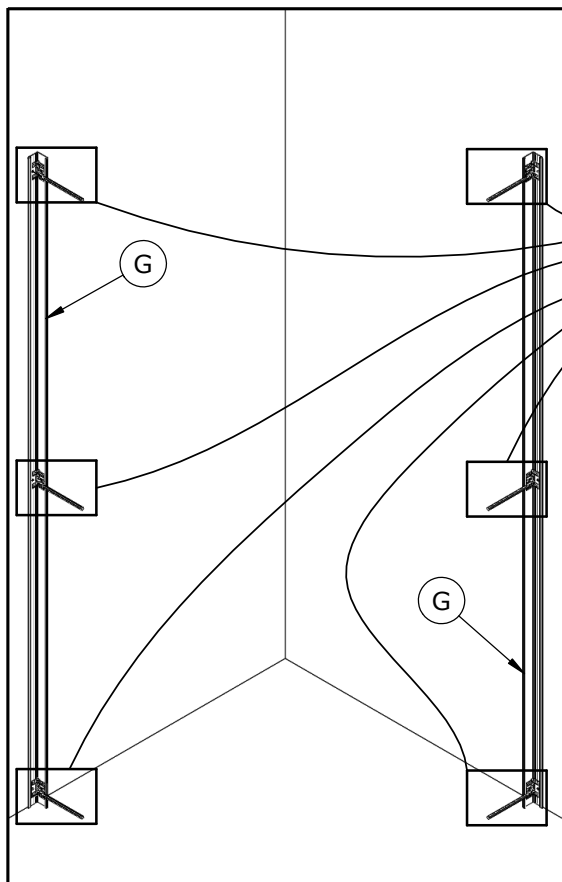

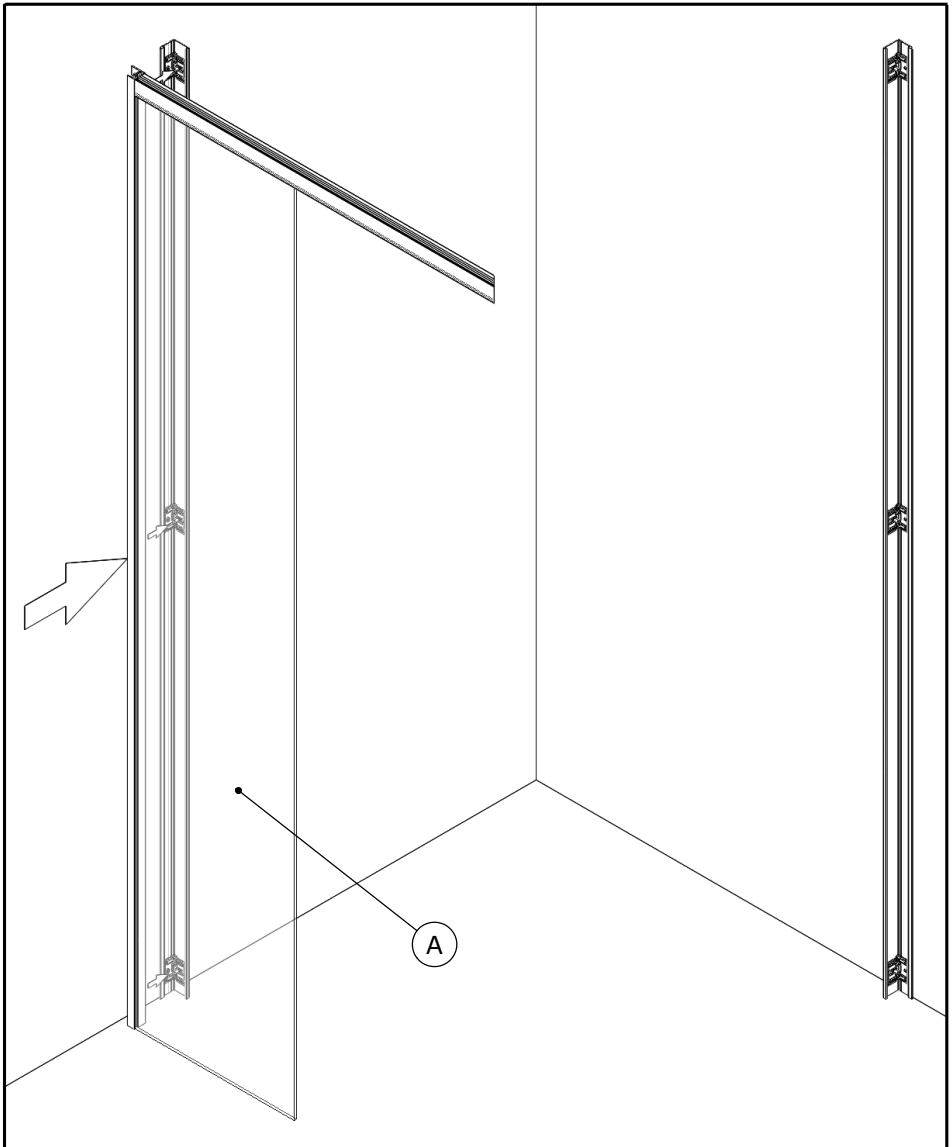

- Ajuster puis serrer ● Fit then tighten
- Regulare e poi serrare
- Stel af en draai vast ● Anpassen dann anziehen

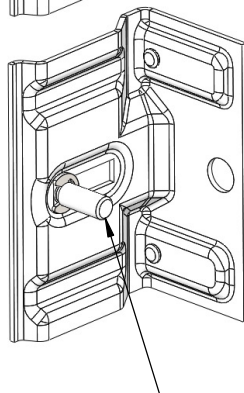
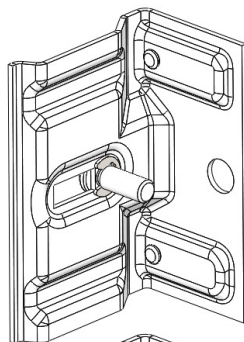

- Si nécessaire, desserrer, régler puis resserrer
- If necessary, loosen, adjust and retighten
- Se necesario, allentare, regulare e stringere
- Draai los, indien nodig, stel af en draai vervolgens weer vast
- Falls erforderlich, lösen, einstellen und wieder festziehen

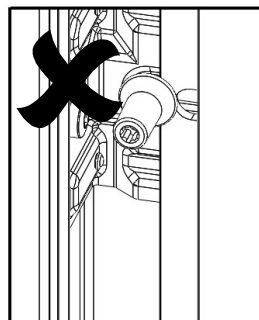
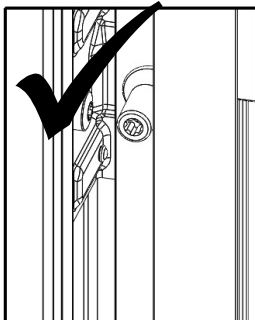
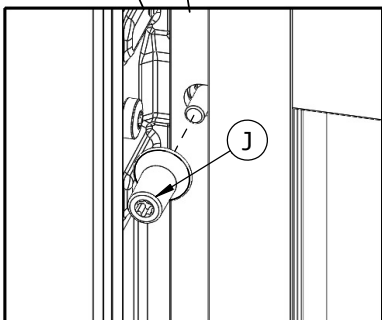
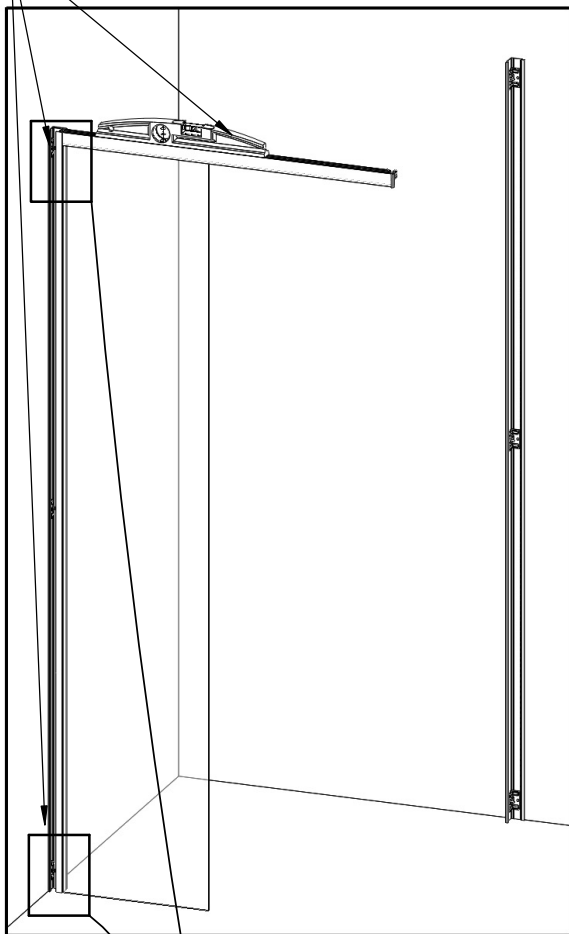

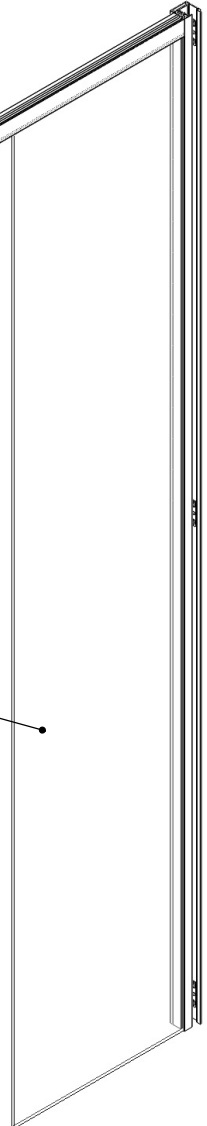
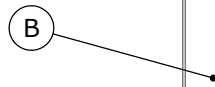
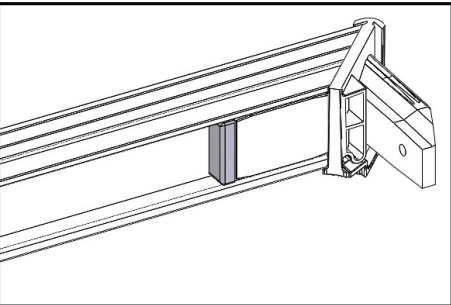
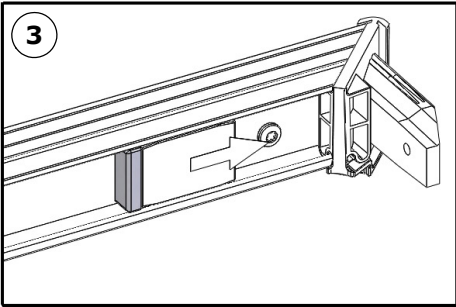
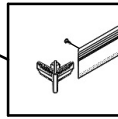
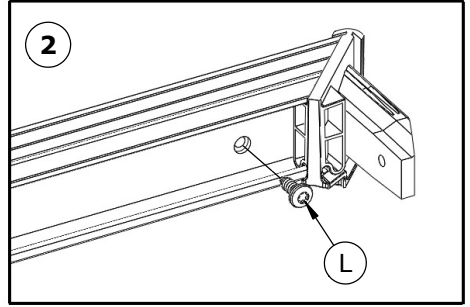
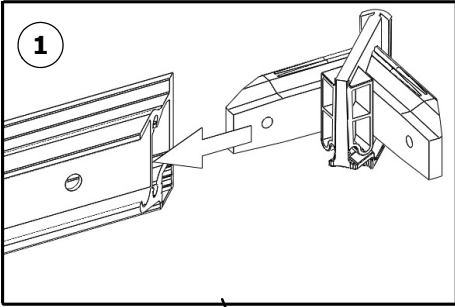

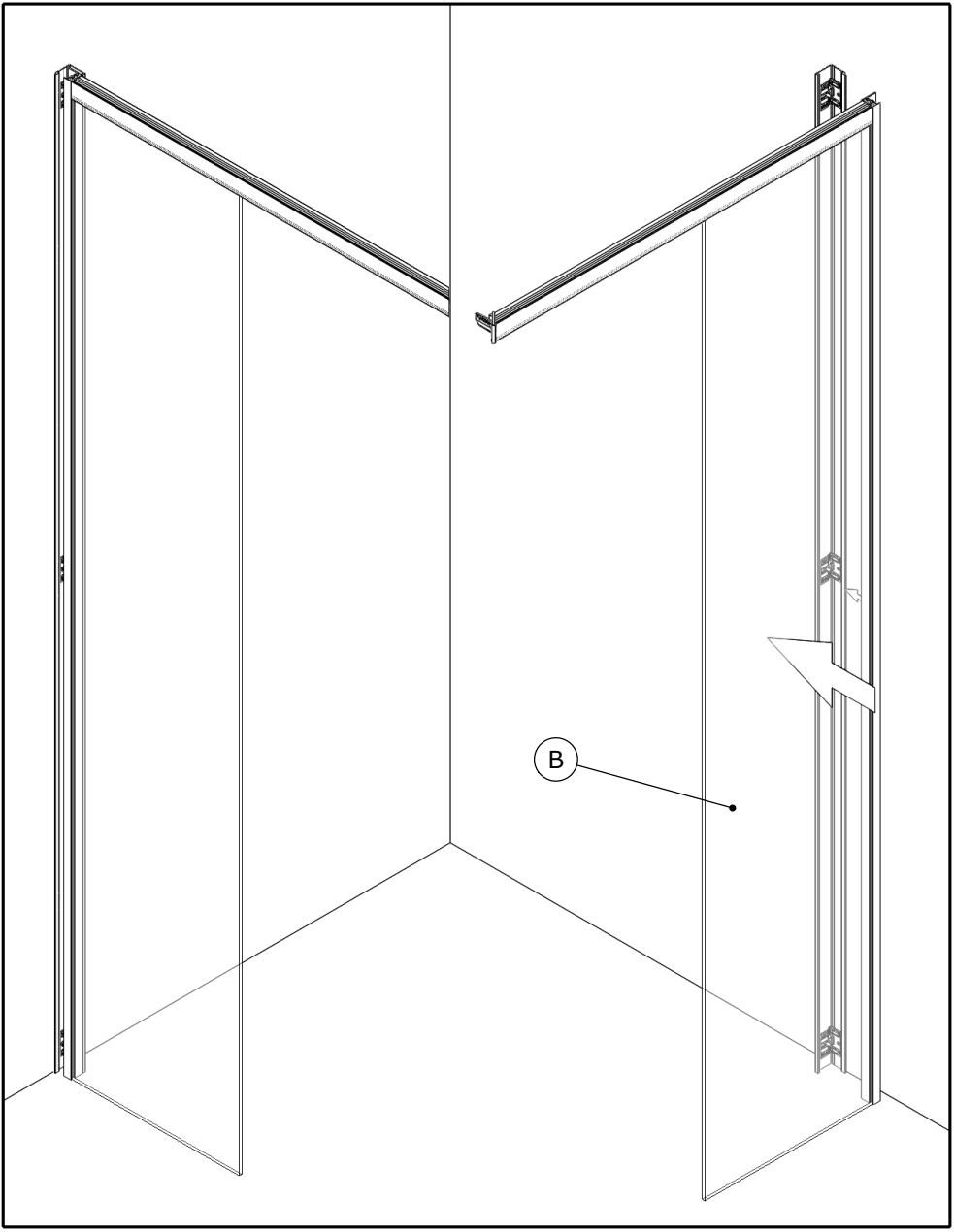

- Adjuster puis serrer ● Fit then tighten
- Regolare e poi serrare
- Stel af en draai vast ● Anpassen dann anziehen

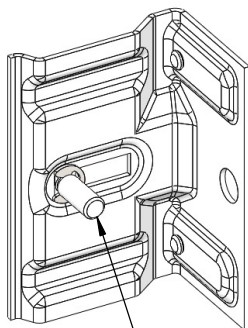
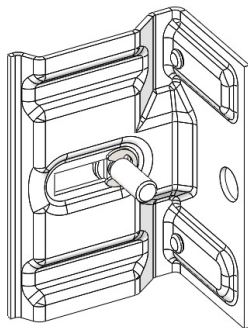
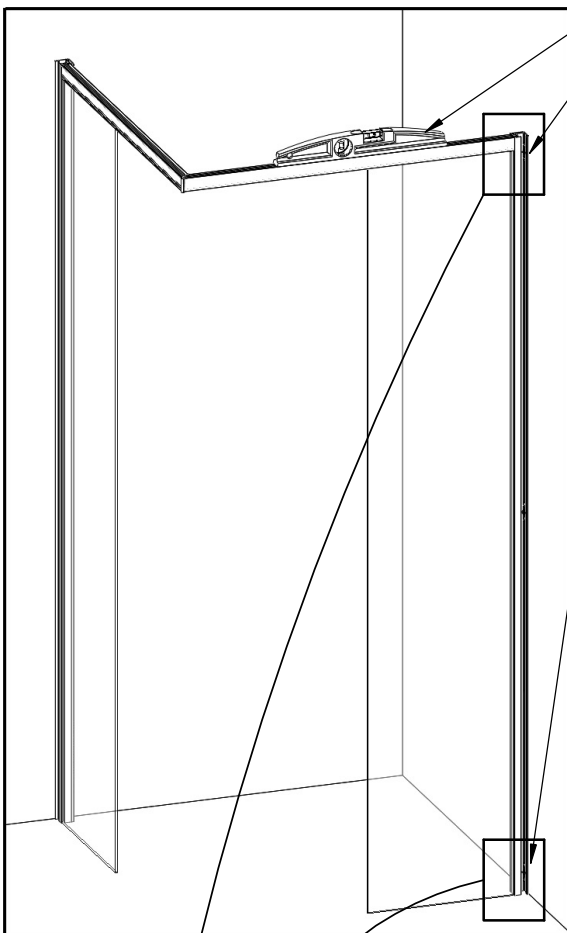

- Si nécessaire, desserrer, régler puis resserrer
- If necessary, loosen, adjust and retighten
- Se necesario, allentare, regular e stringere
- Draai los, indien nodig, stel af en draai vervolgens weer vast
- Falls erforderlich, lösen, einstellen und wieder festziehen

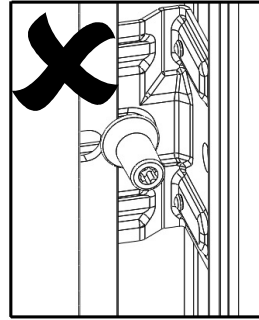
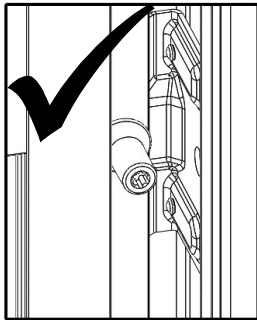
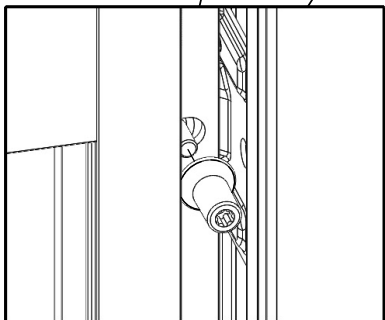

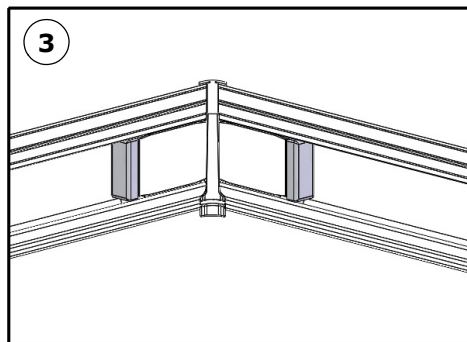
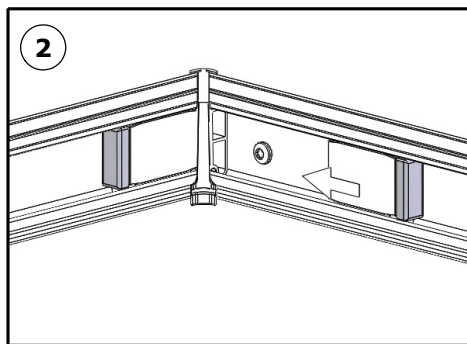
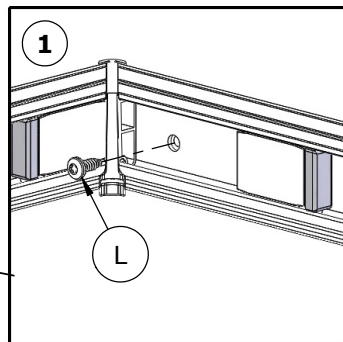
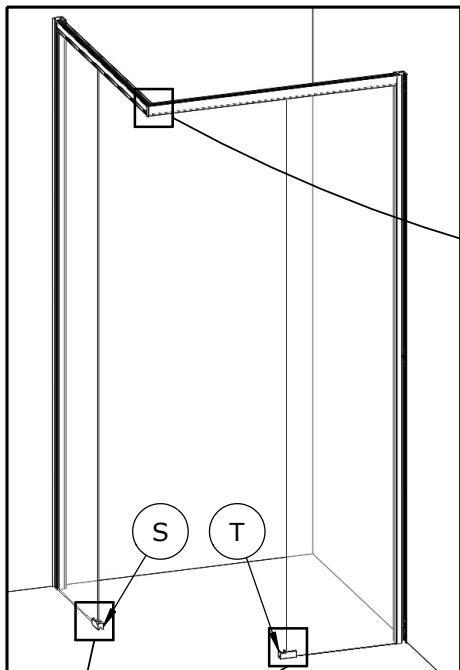

- Retirer
- Remove
- Togliere
- Verwijderen
- Entfernen

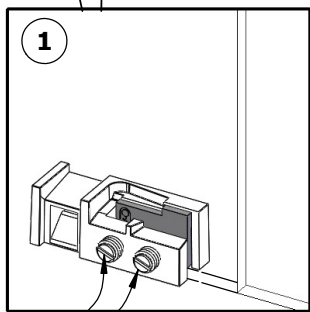

- Desserer ● Loosen
- Allentare
- Losdraaien ● Abschrauben

- Serrer ● Tighten
- Serrare
- Vastdraaien ● Festziehen

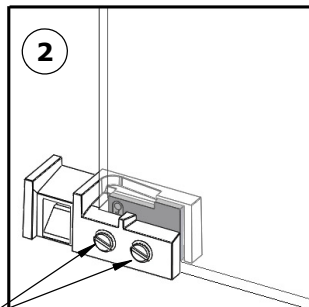

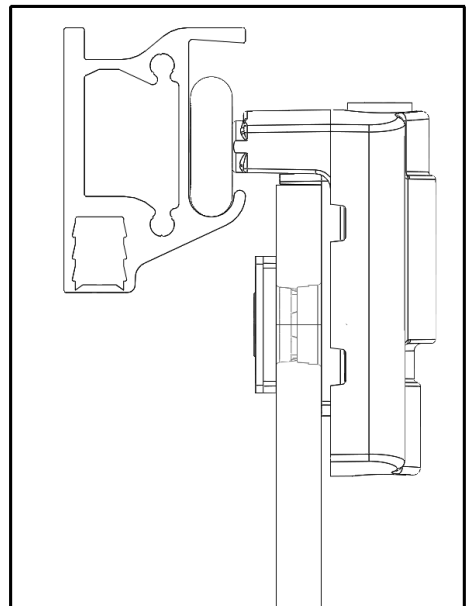
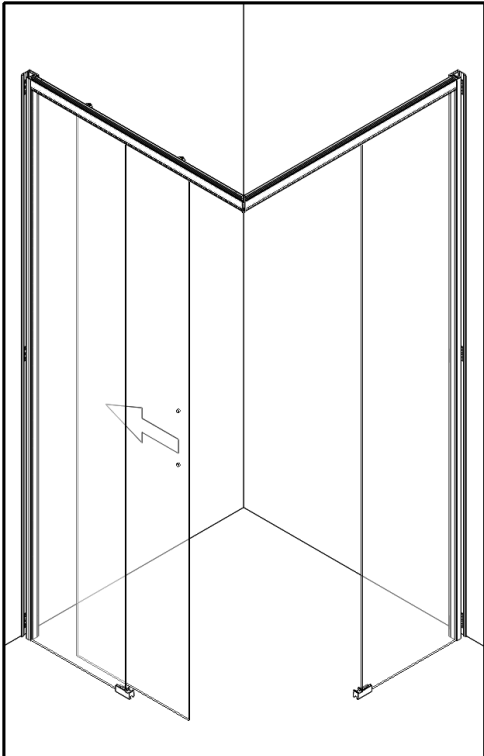
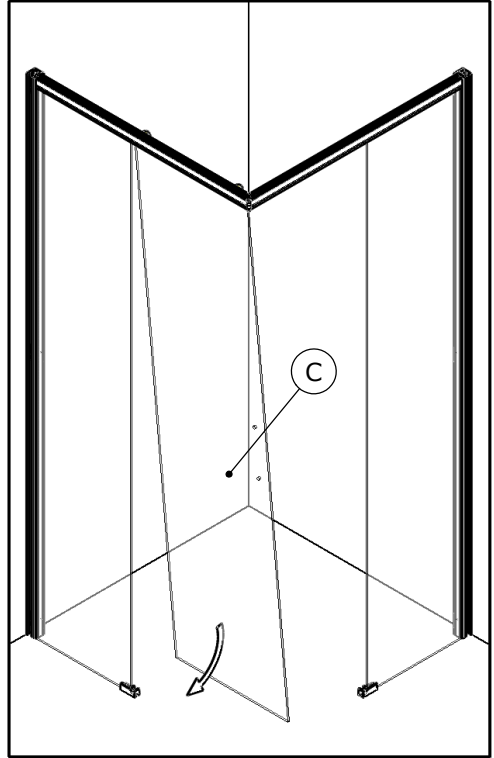
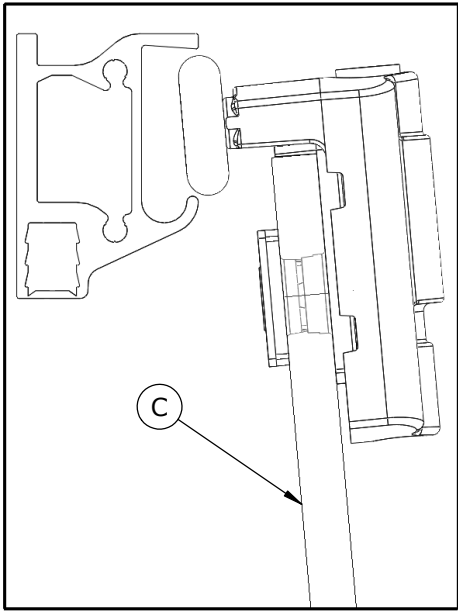

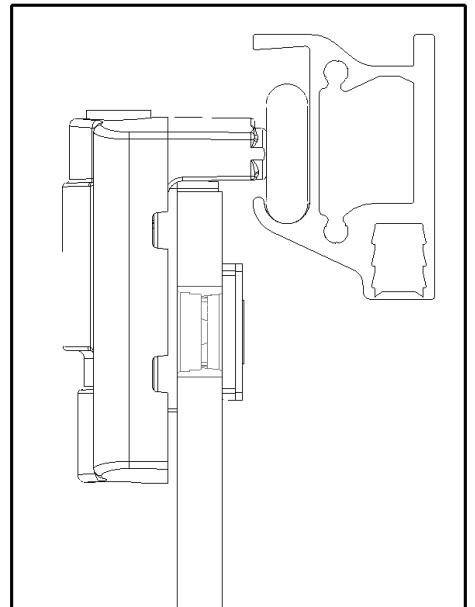
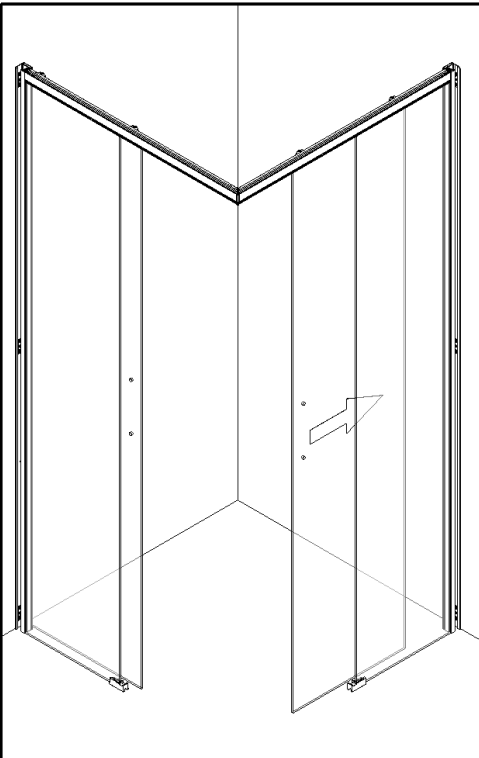
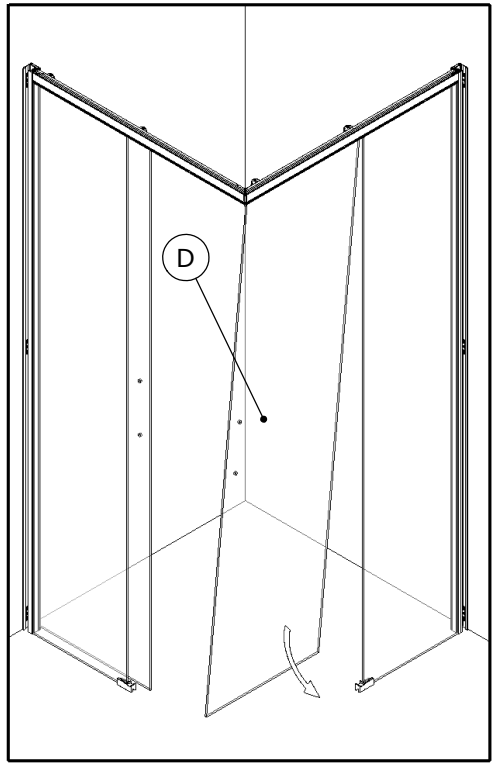
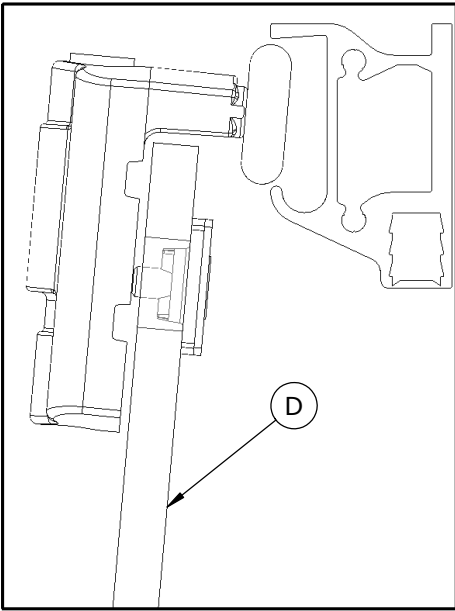

● Intérieur ● Inside
 ● Interior ● Interno
 ● Binnenkant ● Innen

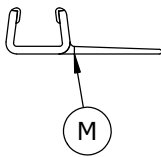

● Extérieur ● Outside
 ● Externo ● Esterno
 ● Buitenkant ● Außen



- Couper (M) en partie haute
- Cut (M) at the top
- Corte (M) en la parte superior
- tagliare (M) in alto
- Snijden (M) in het bovenste deel
- Schnitt (M) im oberen Bereich

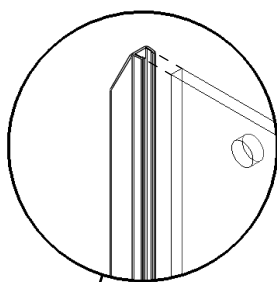

M

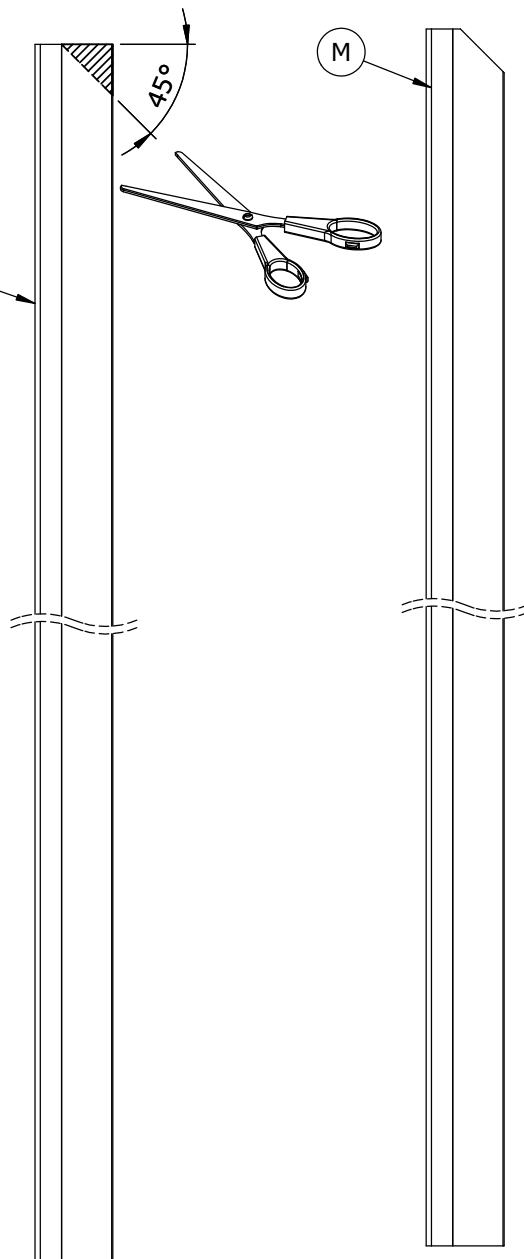

● Extérieur ● Outside
 ● Externo ● Esterno
 ● Buitenkant ● Außen

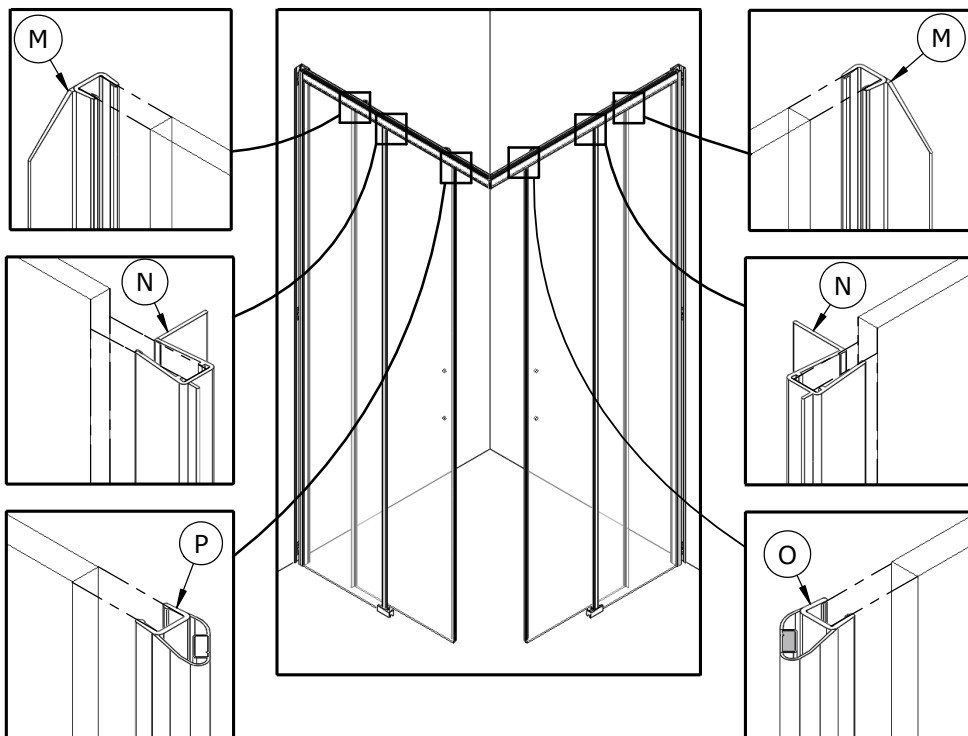

● Couper si nécessaire ● Cut if necessary

● Tagliare si necessario

● Snijden indien nodig ● Bei Bedarf zuschneiden

● Intérieur ● Inside

● Interno

● Binnenkant ● Innen

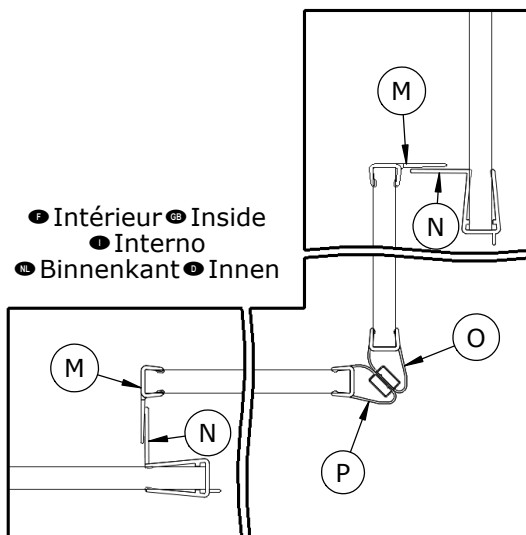

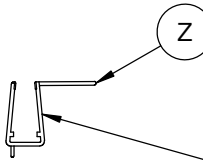
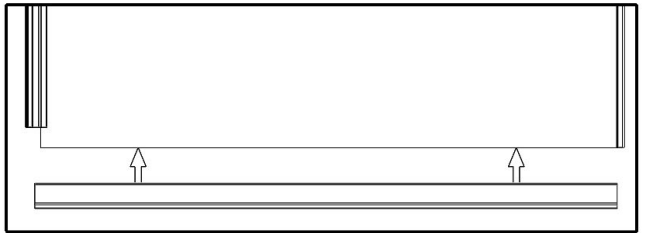
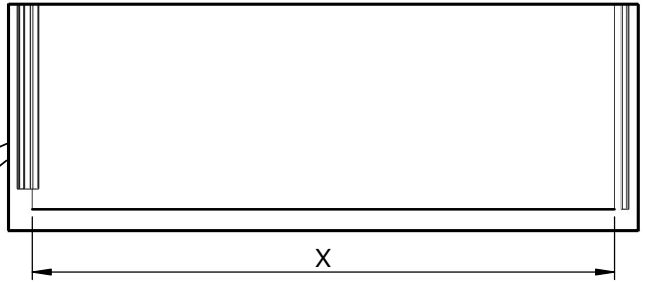
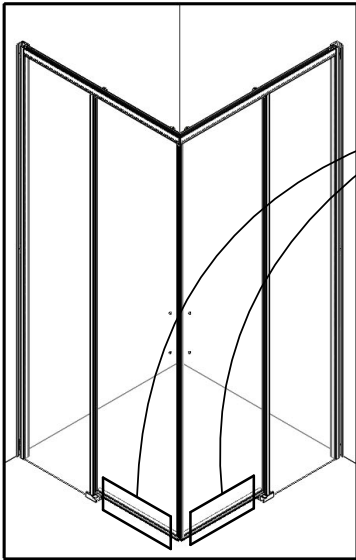

● Intérieur ● Inside
 ● Interno
 ● Binnenkant ● Innen

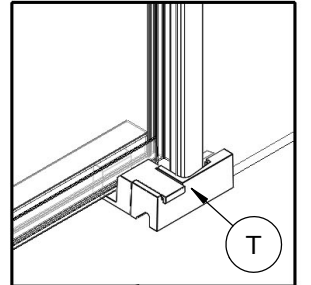
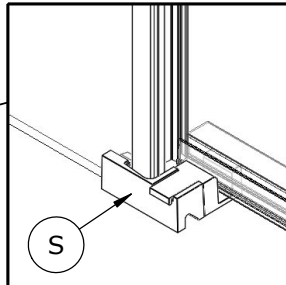
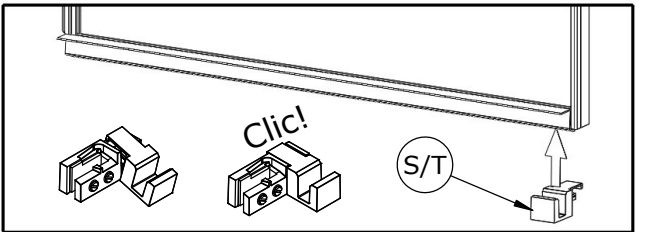
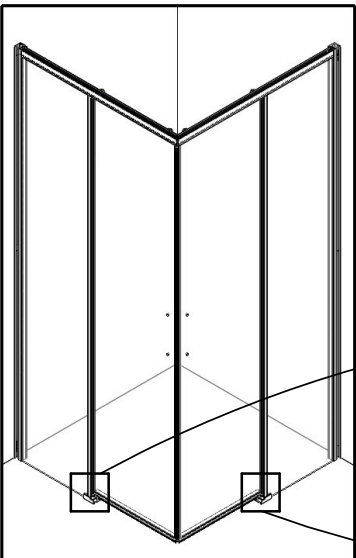

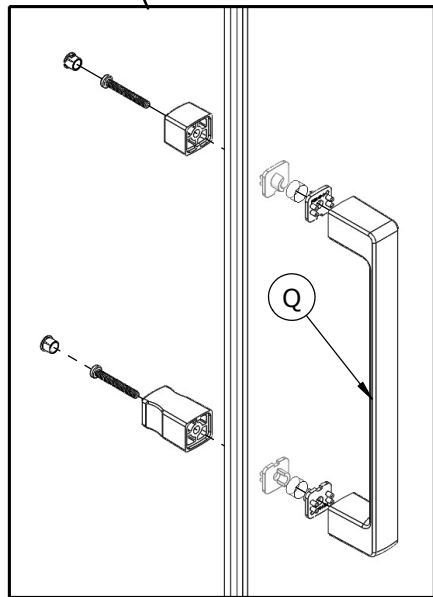
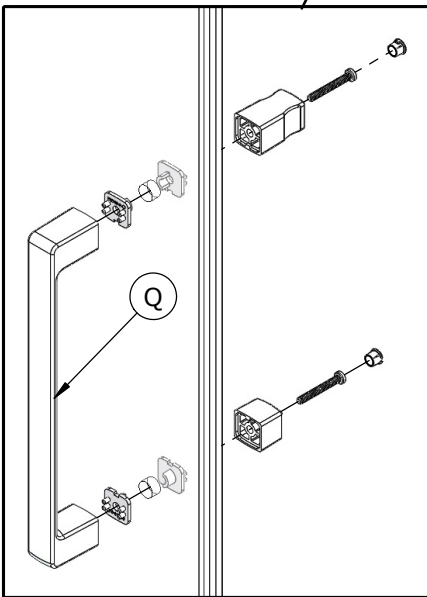
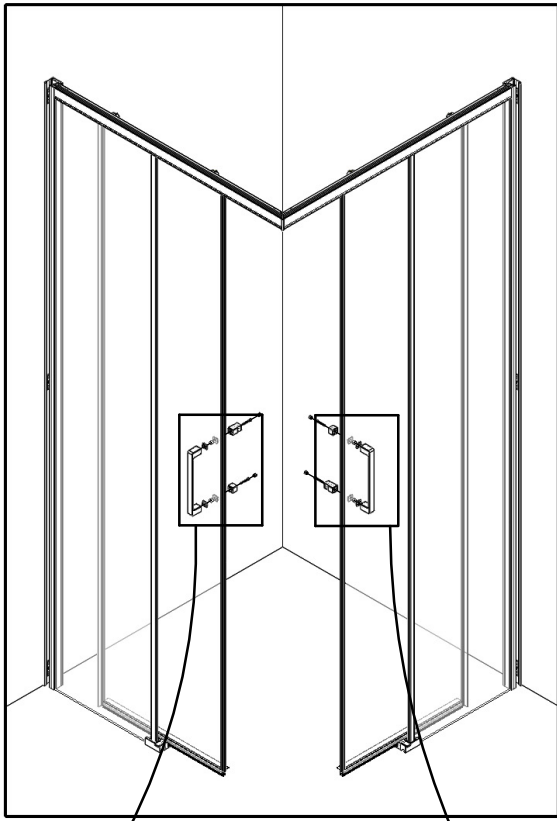

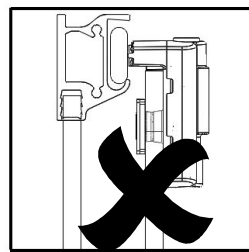
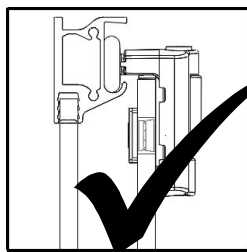
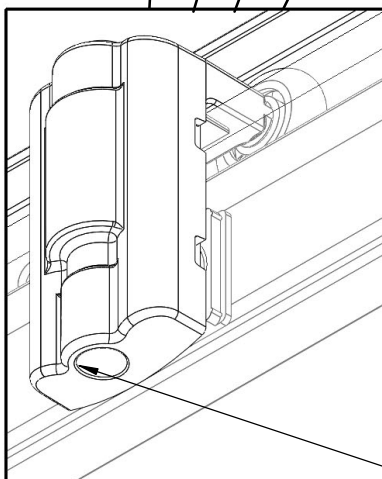
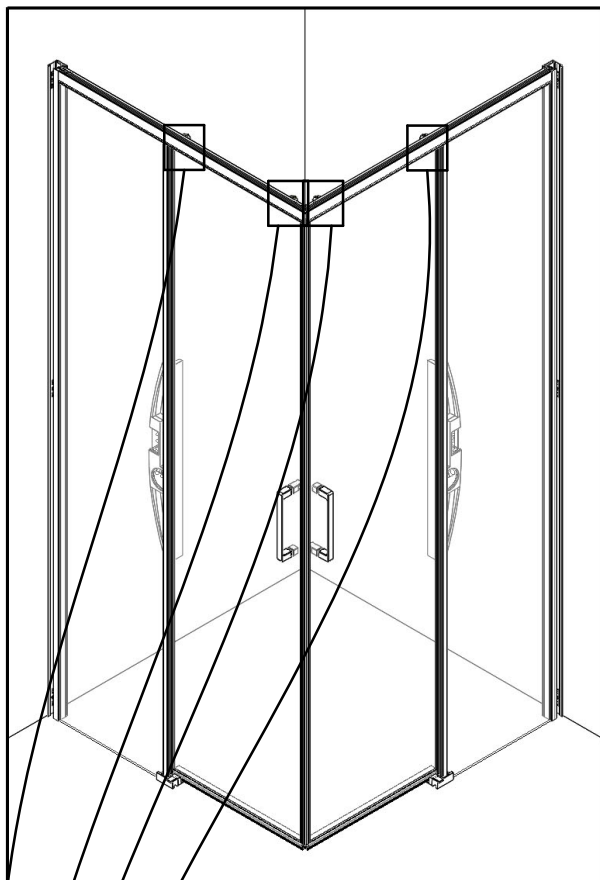

- Régler les porte afin qu'elles soient de niveau
- Adjust the doors so that they are level
- Regolare le porte in modo che siano in bolla
- Stel de deuren zodanig af zodat ze waterpas staan
- Türen waagrecht ausrichten

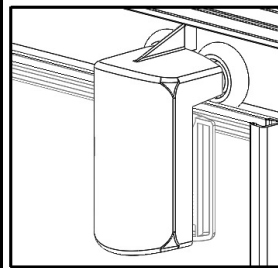
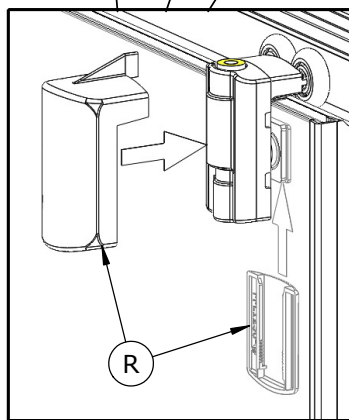
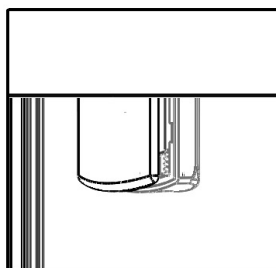
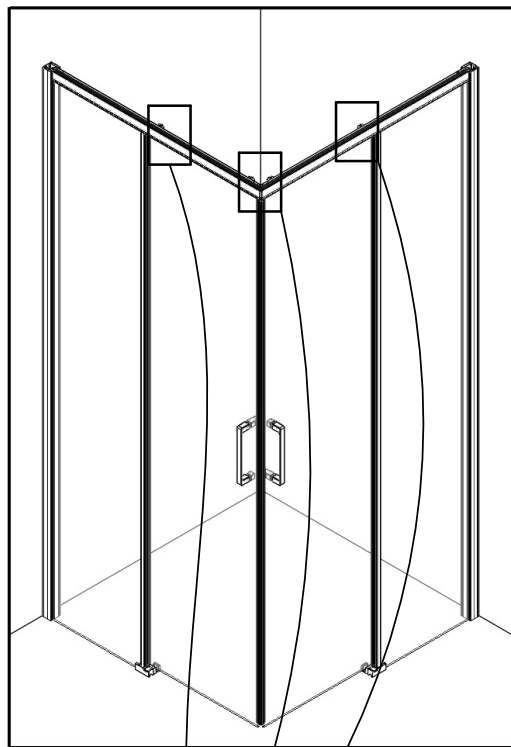

● Extérieur ● Outside
 ● Esterno
 ● Buitenkant ● Außen

● Intérieur ● Inside
 ● Interno
 ● Binnenkant ● Innen

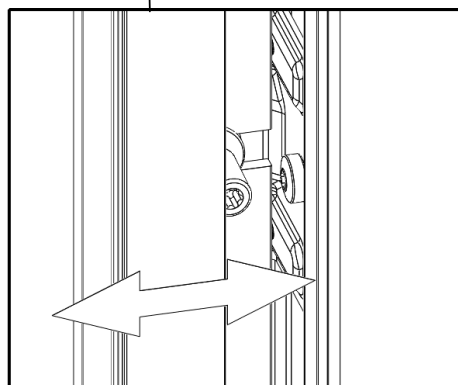
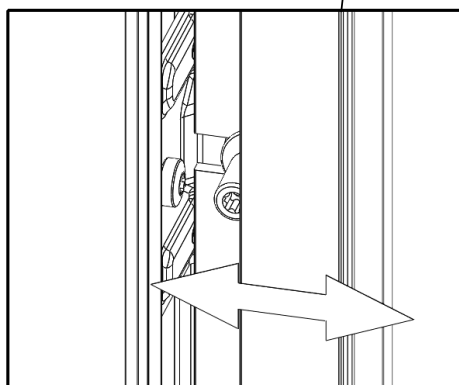
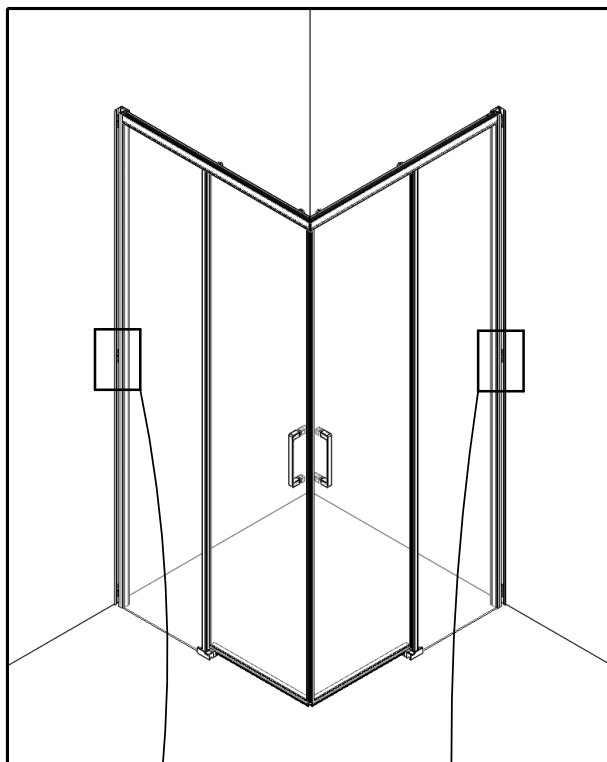

- Si nécessaire, desserrer, régler puis resserrer
- If necessary, loosen, adjust and retighten
- Se necesario, allentare, regular e stringere
- Draai los, indien nodig, stel af en draai vervolgens weer vast
- Falls erforderlich, lösen, einstellen und wieder festziehen

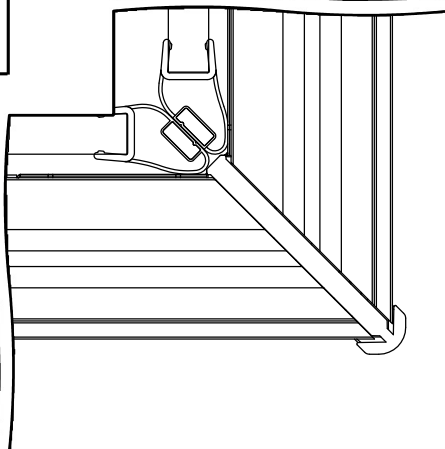
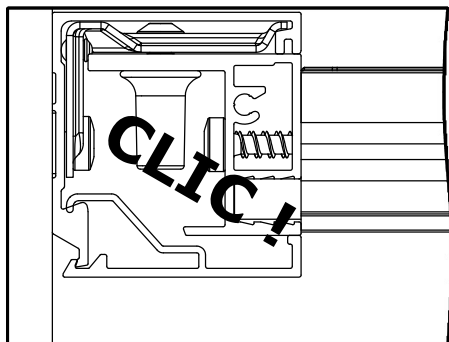
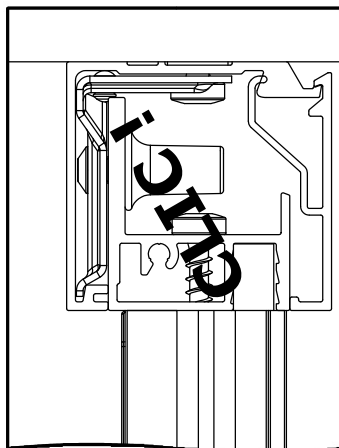
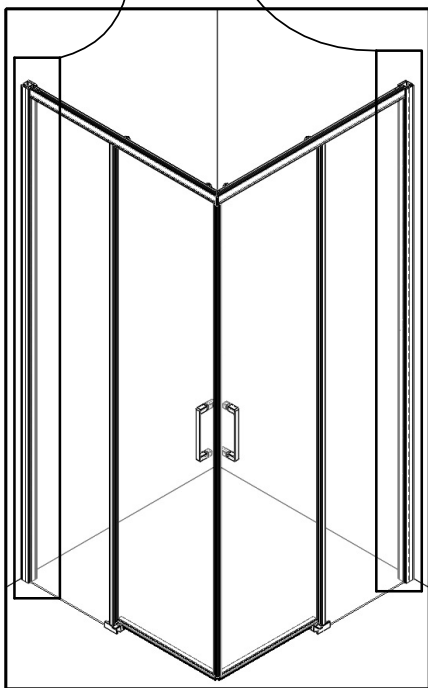
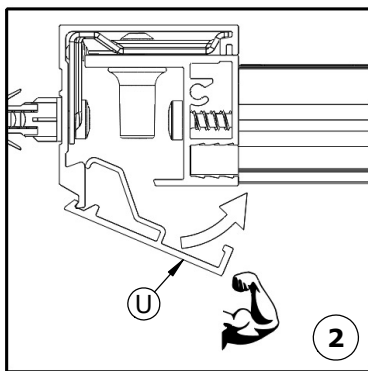
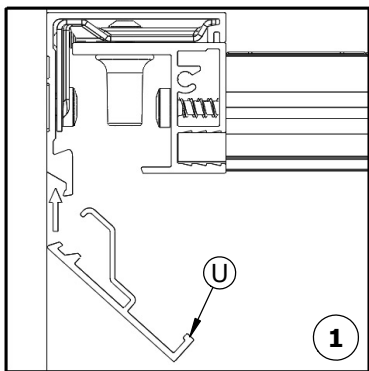

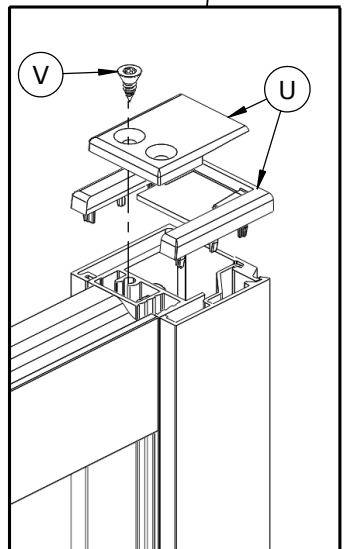
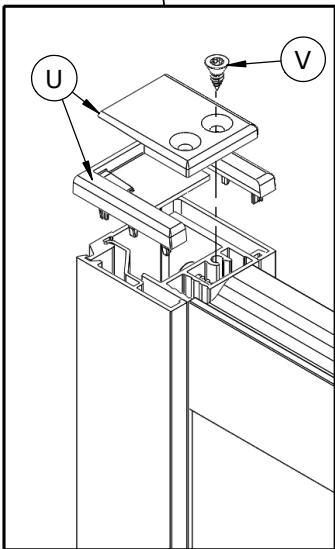
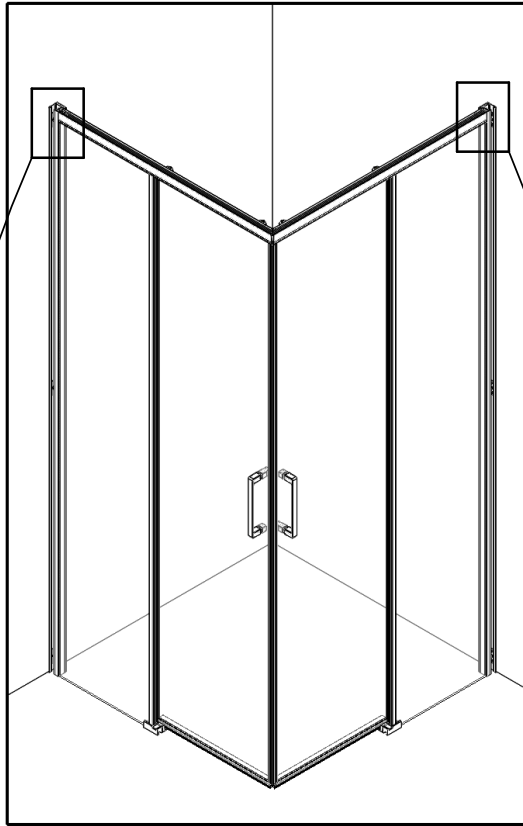

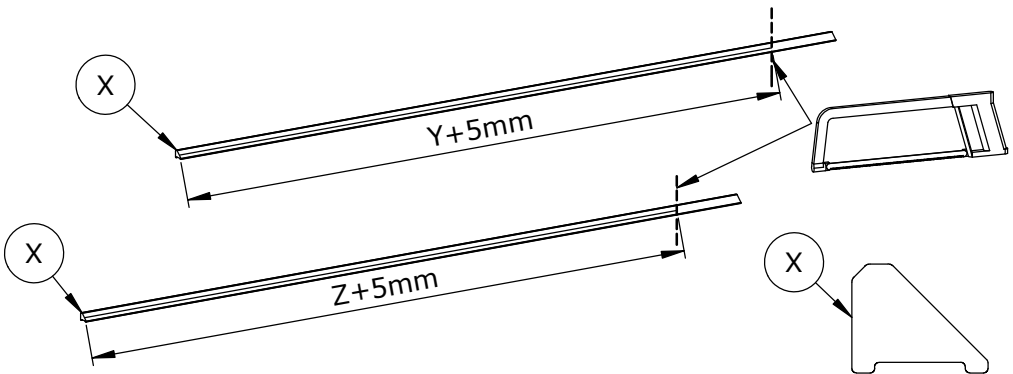
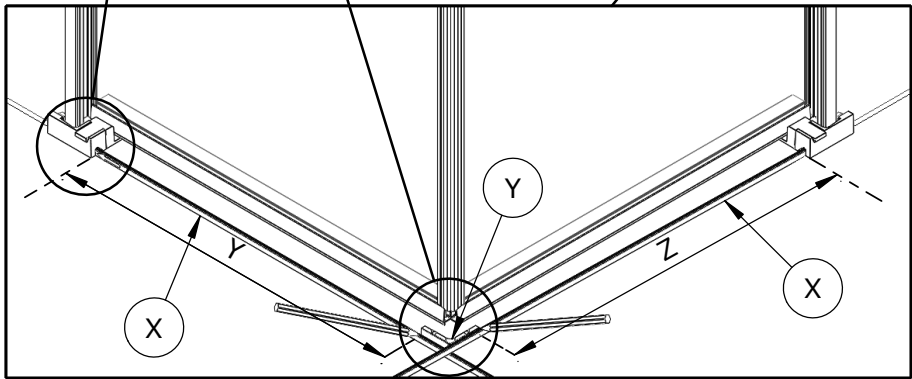
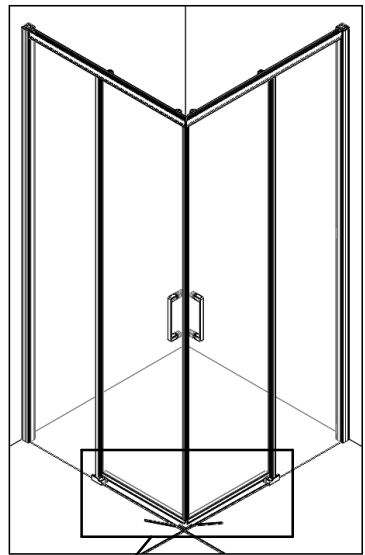
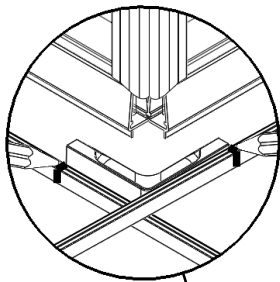
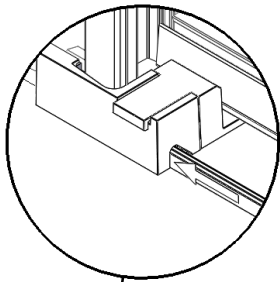

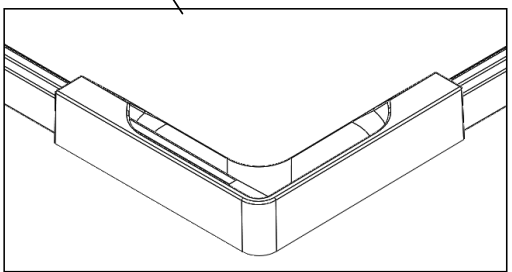
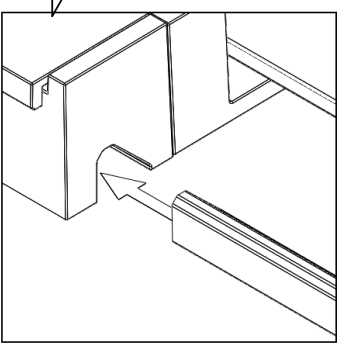
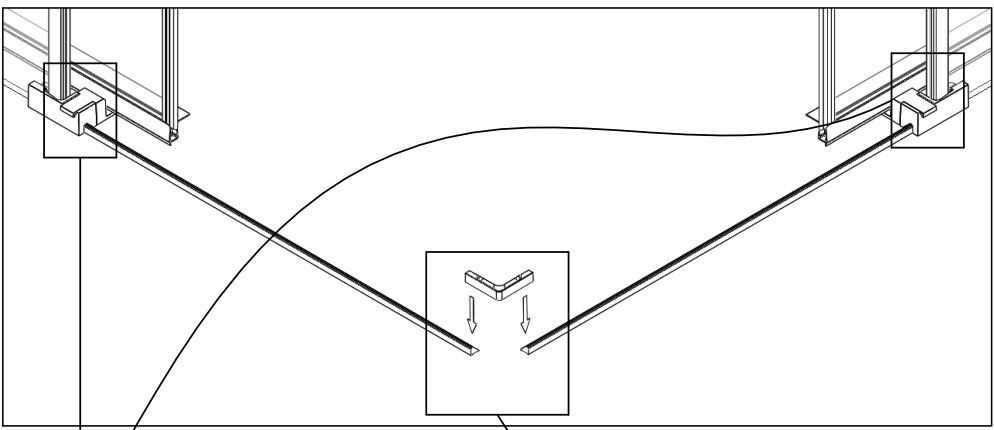
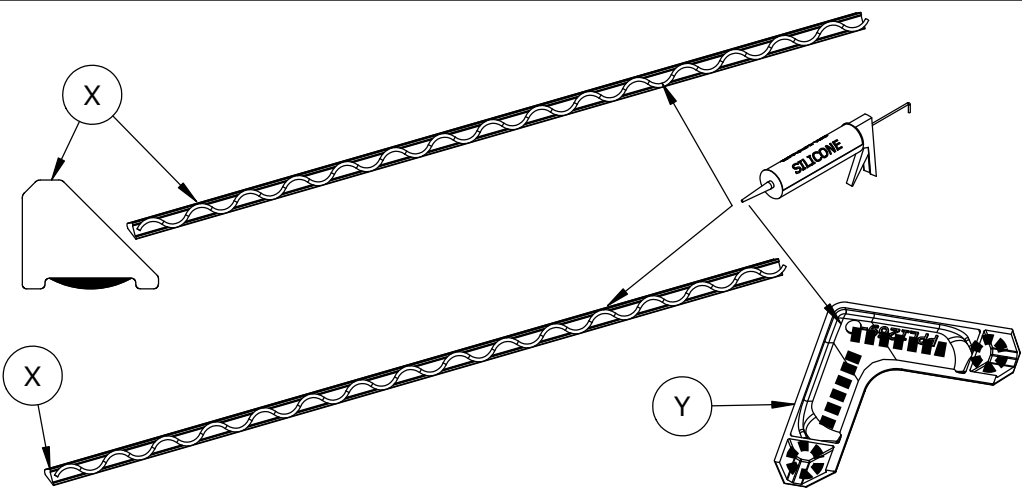

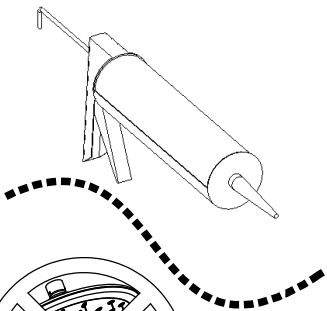

24H

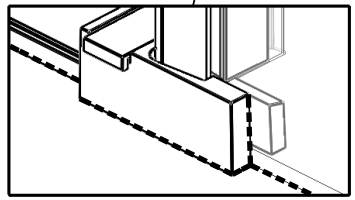
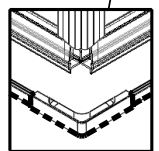
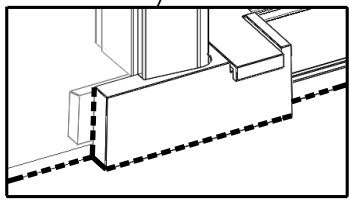
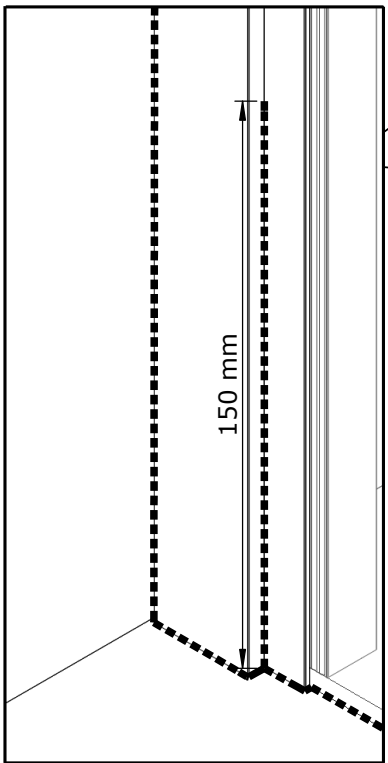
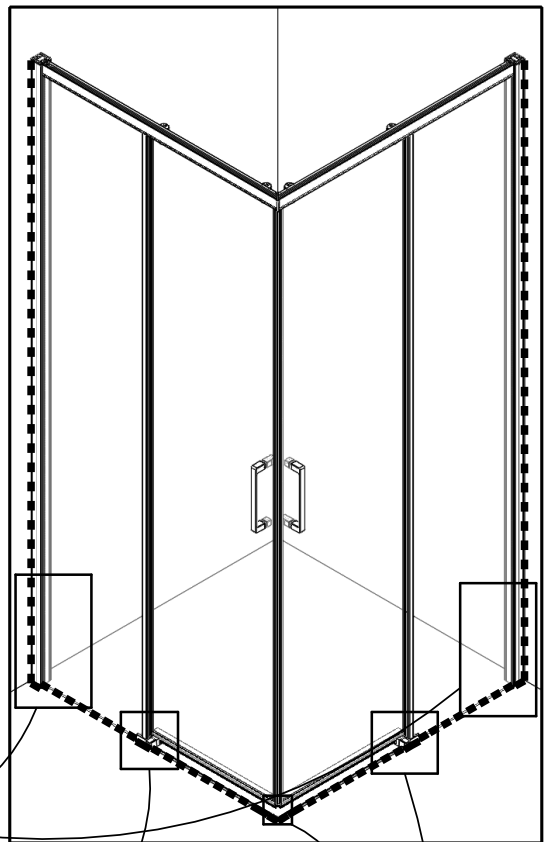

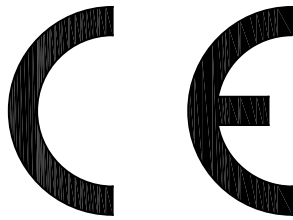

AQUAPRODUCTION, Site industriel,
F - 44680 Chaumes-en-Retz

18

EN 14428

Paroi de douche, fabriquée en verre de silicate
sodo-calcique de sécurité trempé thermiquement

Aptitude au nettoyage : réussite

Résistance à l'impact/propriétés de fragmentation : réussite

Durabilité : réussite



SAV
SERVICE HELPLINES
ASSISTENZA POST-VENDITA
SERVICIO POSTVENTA

FRANCE

02 40 21 29 45

SCHWEIZ

(01) 748 17 44

UK

020 8842 0033

ESPANA

93 544 60 76

IRELAND

04697 33102

NEDERLAND

+31 475 487 100

DEUTSCHLAND

+49 (0) 6074 / 30928 0

BELGIE

+31 475 487 100

ITALIA

(0382) 6181

BELGIQUE

+31 475 487 100

OSTEREICH

+43 1 710 60 70

РОССИЯ

963 19 40, 773 67 22