

- F NOTICE DE MONTAGE (VERSION PIVOTANTE)
- GB INSTALLATION INSTRUCTIONS (PIVOTING VERSION)
- E MANUAL DE INSTALACION (VERSION GIRATORIA)
- I ISTRUZIONI DI MONTAGGIO (VERSIONE GIREVOLE)
- NL INSTALLATIE VOORSCHRIFTEN (DRAAIBARE VERSIE)
- D INSTALLATIONSANLEITUNG (SCHWINGTÜR)

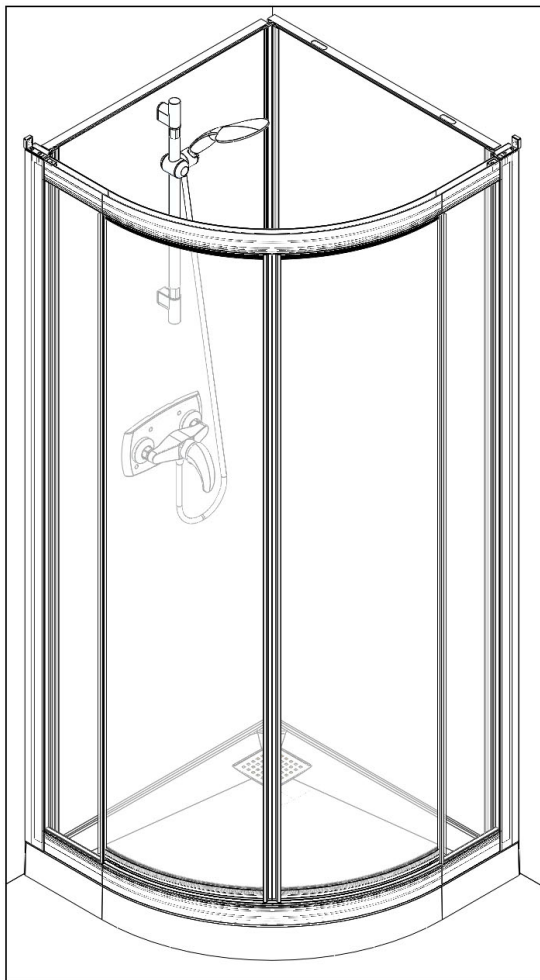

- Attention aux étapes :
- Check installation steps :
- Atención a los pasos :
- Attenzione ai passi :
- Aandacht voor de stappen :
- Achtung vor den Schritten :

P. 10 - 13 - 15

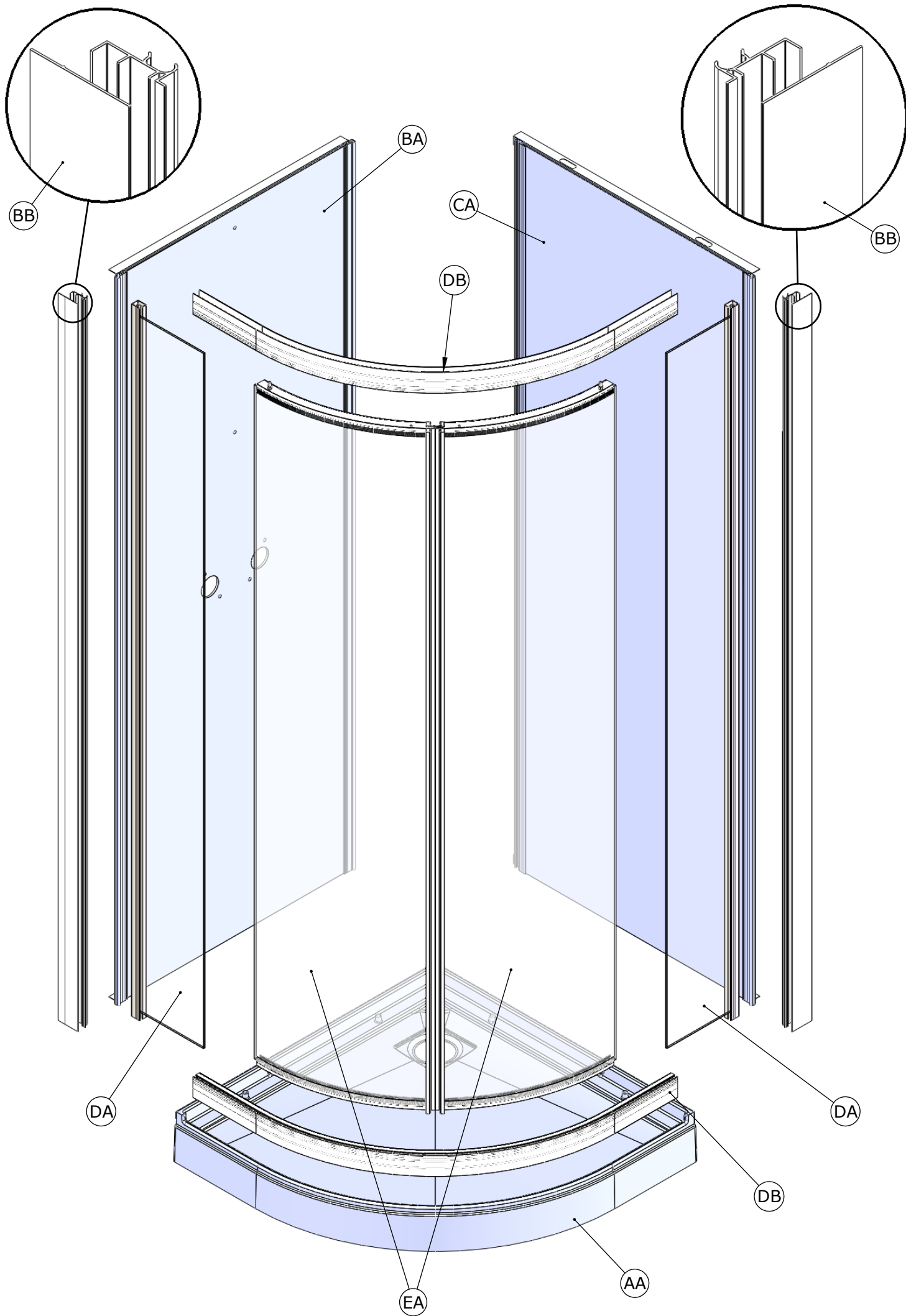

F PIECES DETACHEES **GB** SPARE PARTS **E** PIEZAS DE REPUESTO
I PEZZI DI RICAMBIO **NL** ONDERDELEN **D** ERSATZTEILE

Rep	80R		90R		Qté
	BAS/LOW	HAUT/HIGH	BAS/LOW	HAUT/HIGH	

COLIS 1					
AA	REC415	REC421	REC416	REC422	1
AB	BOND14				1
AC	TOL54				1
AD	TUY62				1
AE	JOI292				1

COLIS 2					
BA	CP369	CP371			1
BB	5003B01				2
BC	S1555-A				1

COLIS 3					
CA	CP368	CP370			1

COLIS 4					
DA	C8388	C9030			2
DB	4194				2
DC	VIS41				8
DD	JOI236				4
DE	JOI231				2
DF	MOU25 / MOU26				4
DG	S2125				1

COLIS 5					
EA	C8368				2
EB	JOI233				2
ED	FIX18				4
EE	PPL608				4
EF	PPL774				4
EG	VIS149				4
EH	RON48				2

BOITE					
FA	Mitigeur MECA	MIT68			1
	Mitigeur THERMO	MIT14			1
	FB	TUY60			1
	FC	TUY61			1
	FD	ECR77			6
	FE	VIS200			6
	FF	CAP18G			4
	FG	KIT109			1
	FH	KIT212			1
	FI	FLEX05			1

Colis 1

S1552

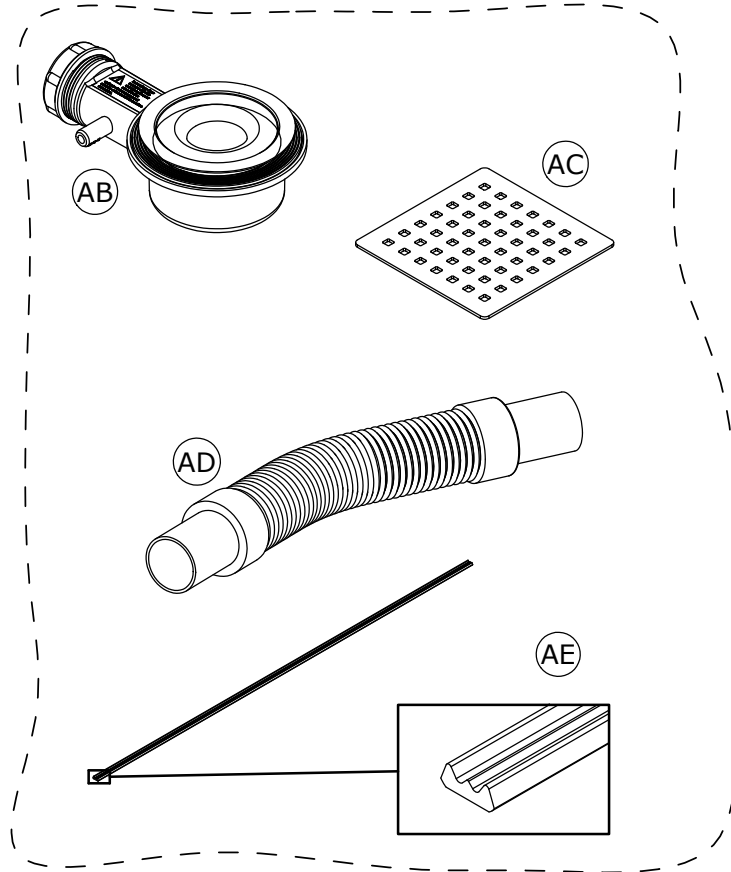
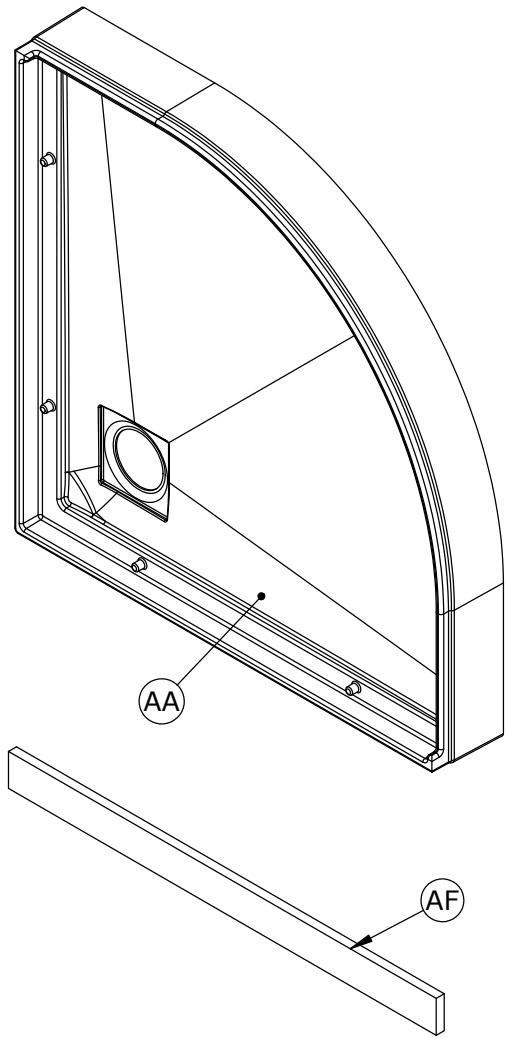

Colis 2

S1555-A

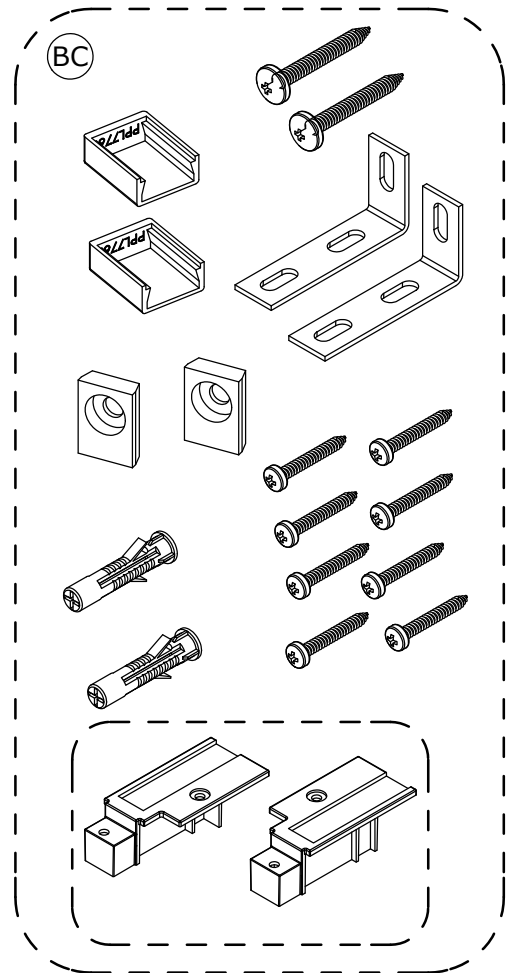
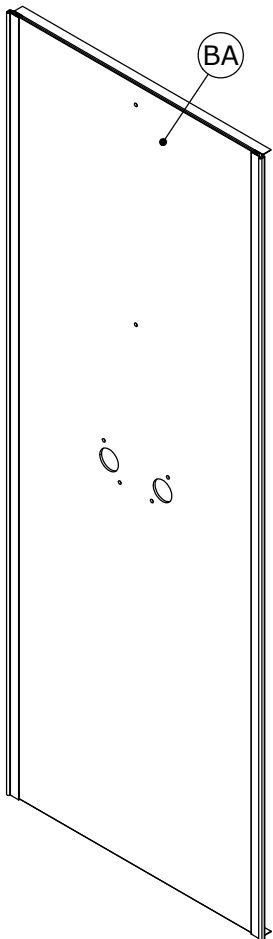

Colis 3

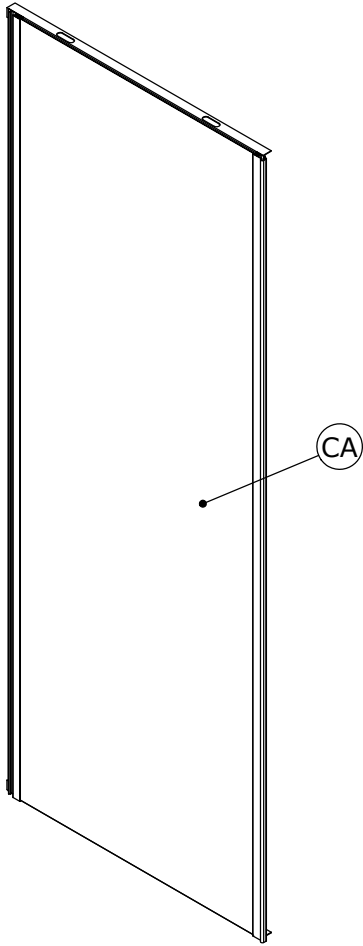

Colis 4

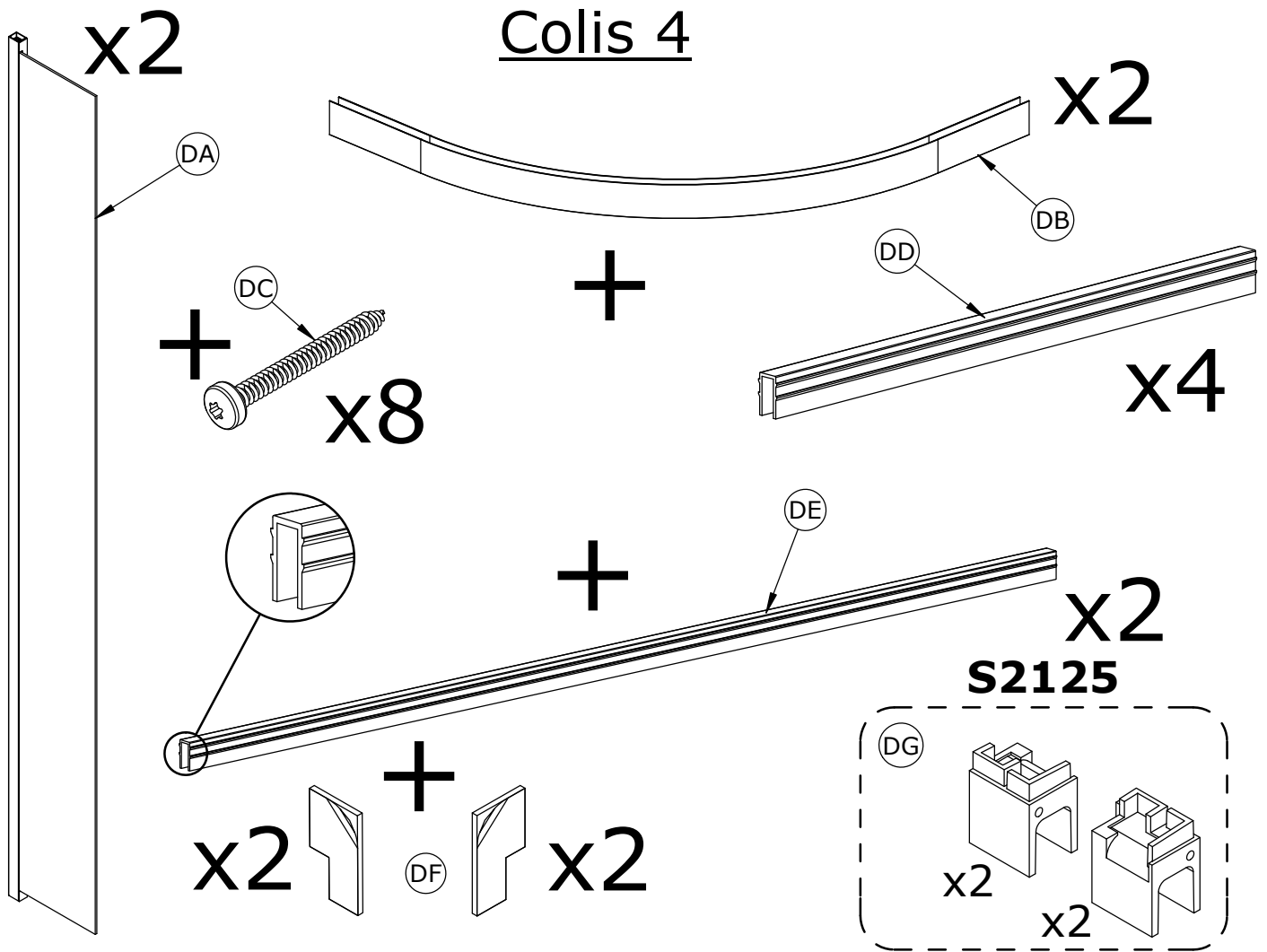

Colis 5

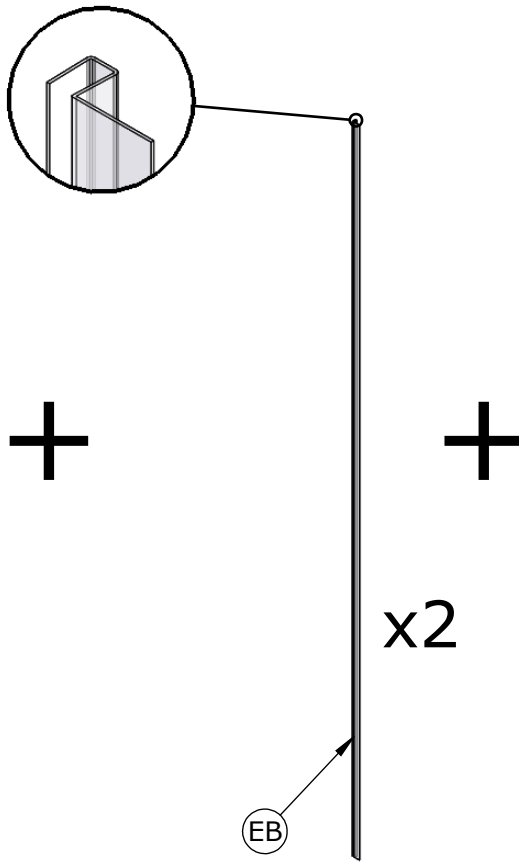
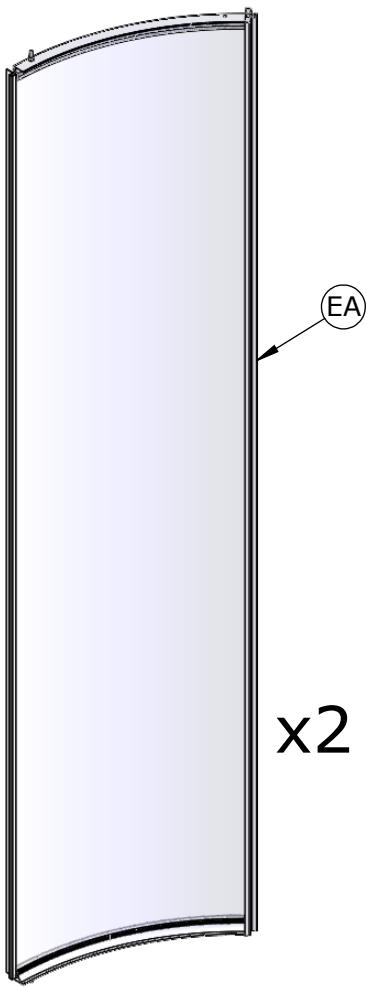

S1557

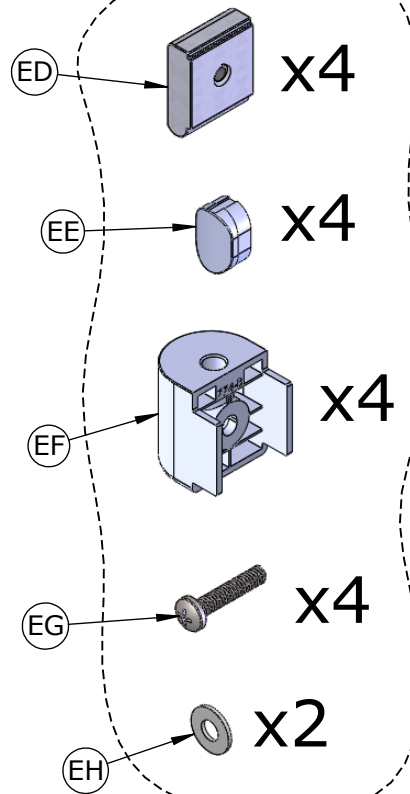

BOITE

Mitigeur MECA

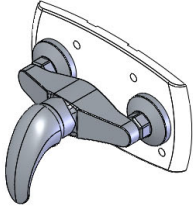

OU

Mitigeur THERMO

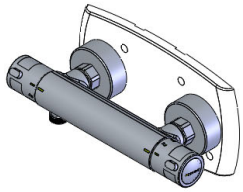

(FA)

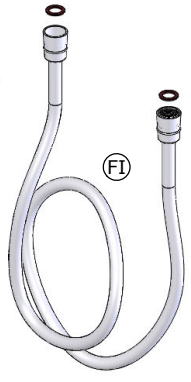
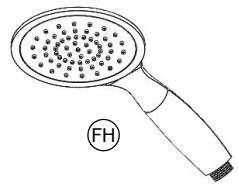
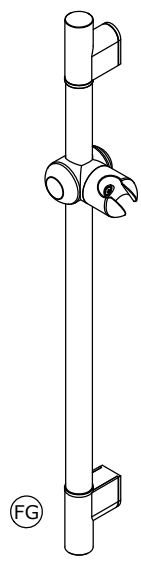
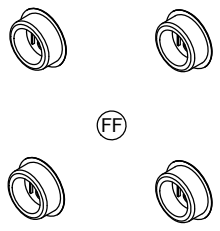
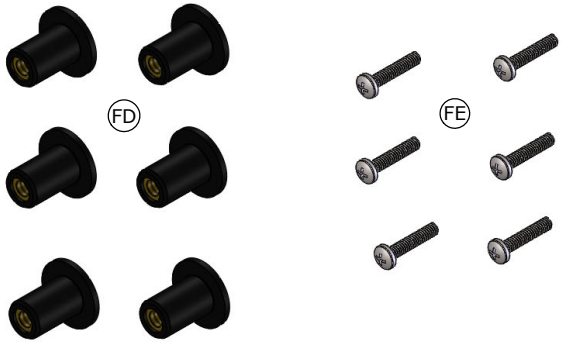
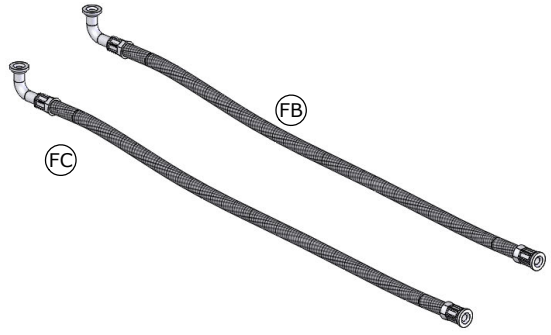

● **F** Matériel nécessaire ● **GB** Tools required ● **E** Herramientas necesarias
● **I** Materiale necessario ● **NL** Benodigd gereedschap ● **D** Werkzeuge erforderlich

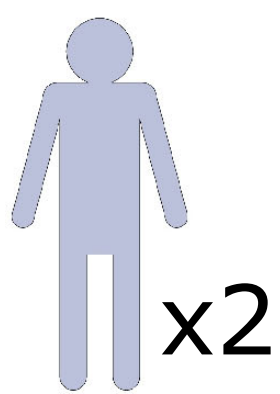
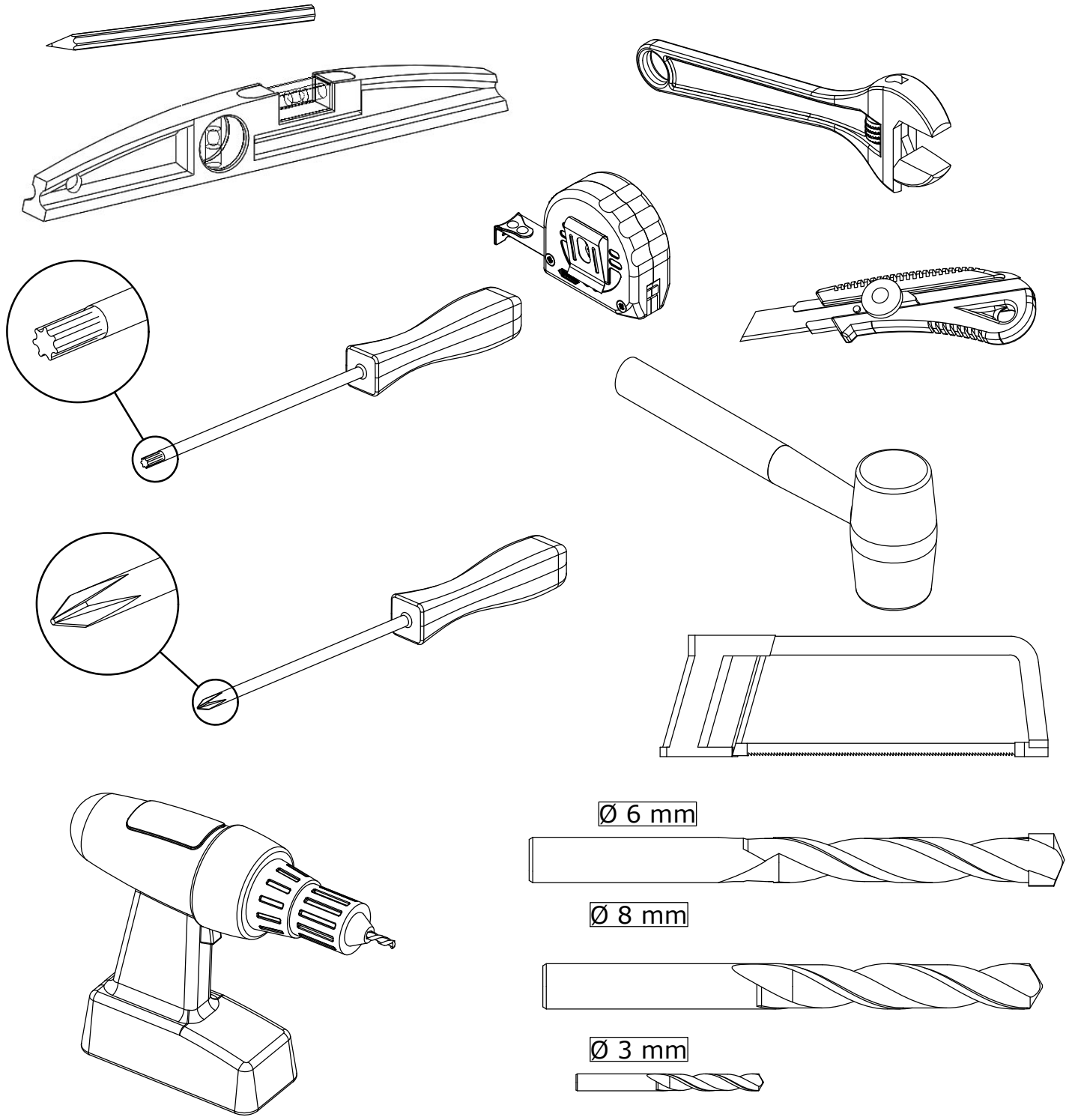

●REVERSIBILITE ●REVERSIBILITY ●REVERSIBILIDAD
 ●REVERSIBILITA ●OMKEERBAARHEID ●WAHLWEISE MONTAGE

- MONTAGE A GAUCHE
 ●LEFT HAND
 ●MONTAJE A LA IZQUIERDA
 ●MONTAGGIO A SINISTRA
 ●MONTAGE LINKS
 ●MONTAGE LINKS

- MONTAGE A DROITE
 ●RIGHT HAND
 ●MONTAJE A LA DERECHA
 ●MONTAGGIO A DESTRA
 ●MONTAGE RECHTS
 ●MONTAGE RECHTS

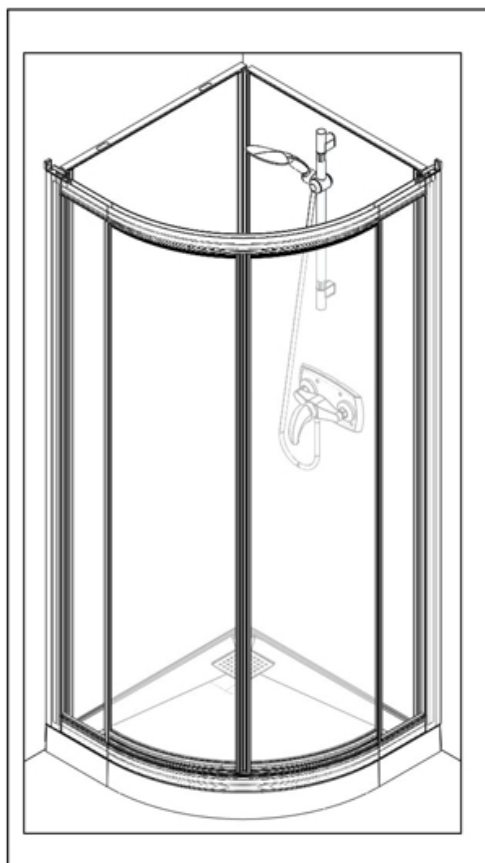
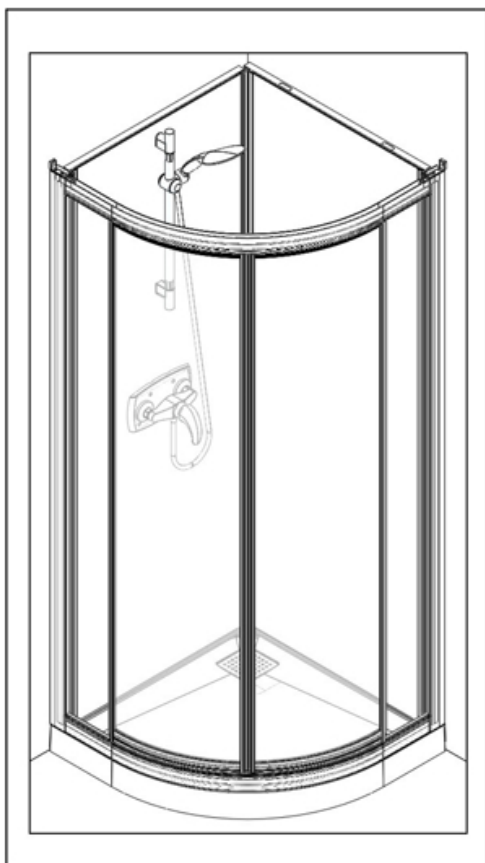

●Vous avez la possibilité de réaliser un montage à droite ou un montage à gauche. Notre notice d'installation décrit un montage à gauche. Si vous voulez réaliser un montage à droite, il vous suffit d'inverser le montage.

●This cubicle can be installed either left or right hand. These installation instructions show a left hand installation.

●Puede realizar un montaje a la derecha o un montaje a la izquierda. Nuestro folleto de instalación describe un montaje a la izquierda. Si desea montar su cabina a la derecha sólo tendrá que realizar el montaje al contrario.

●Avete la possibilità di effettuare il montaggio a destra o a sinistra. Il nostro manuale descrive il montaggio a sinistra. Se volete realizzare il montaggio a destra è sufficiente invertire varie fasi di montaggio.

●U kunt de douchecabine rechts of links monteren. Onze handleiding beschrijft de links montage van de cabine. Keer de montage om als u de cabine rechts wilt monteren.

●Sie haben die Möglichkeit, eine Montage auf der linken Seite oder eine Montage auf der rechten Seite durchzuführen. Unsere Montageanleitung beschreibt eine Montage auf der linken Seite. Wenn Sie die Montage lieber auf der rechten Seite durchführen wollen, müssen Sie nur den Montageprozess umkehren.

01

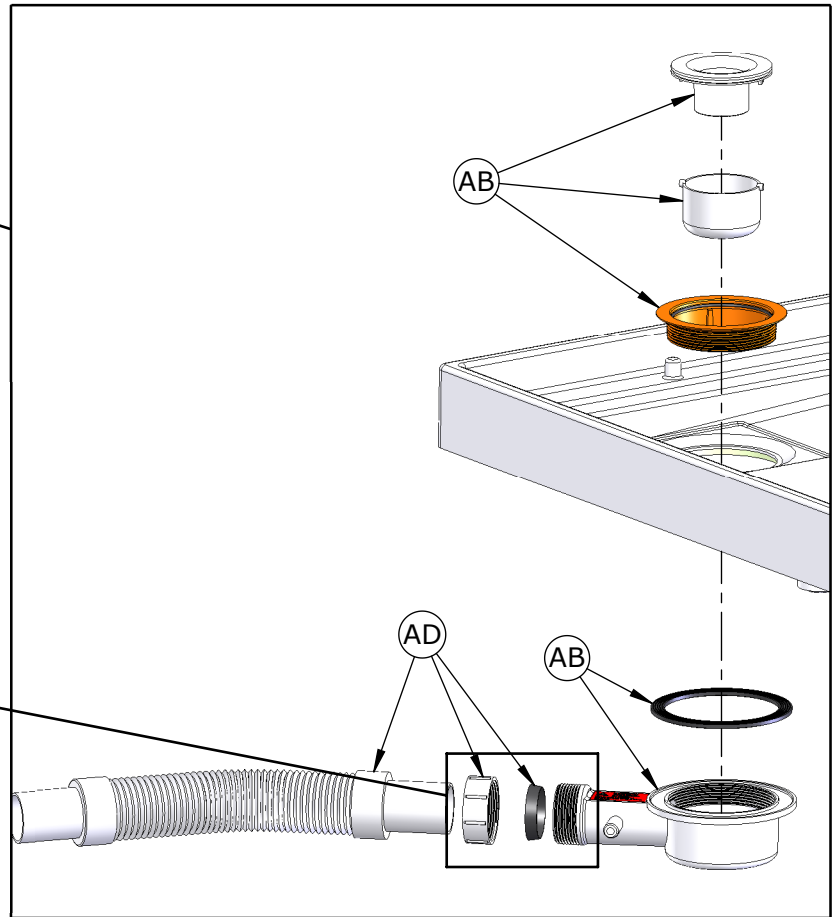
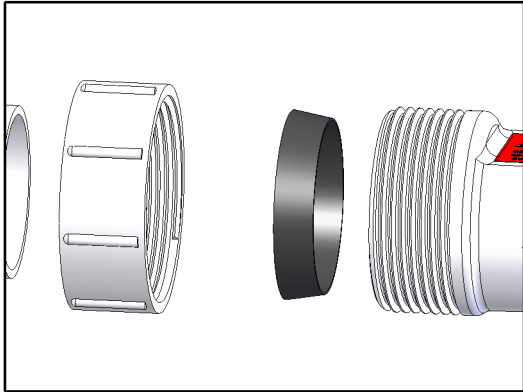
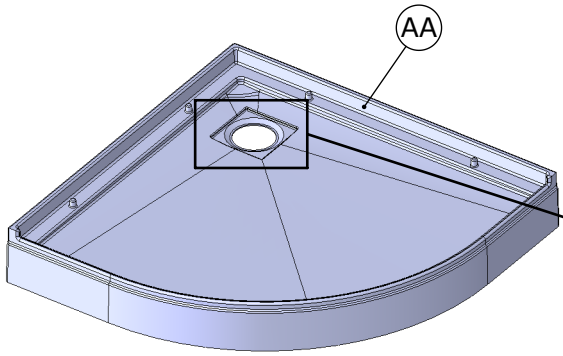

02

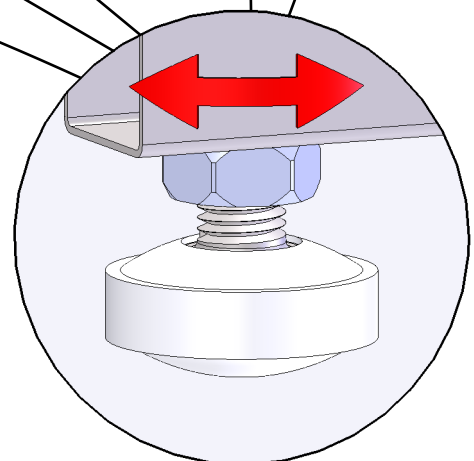
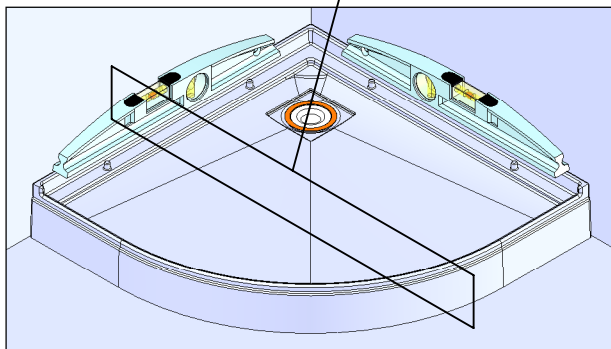
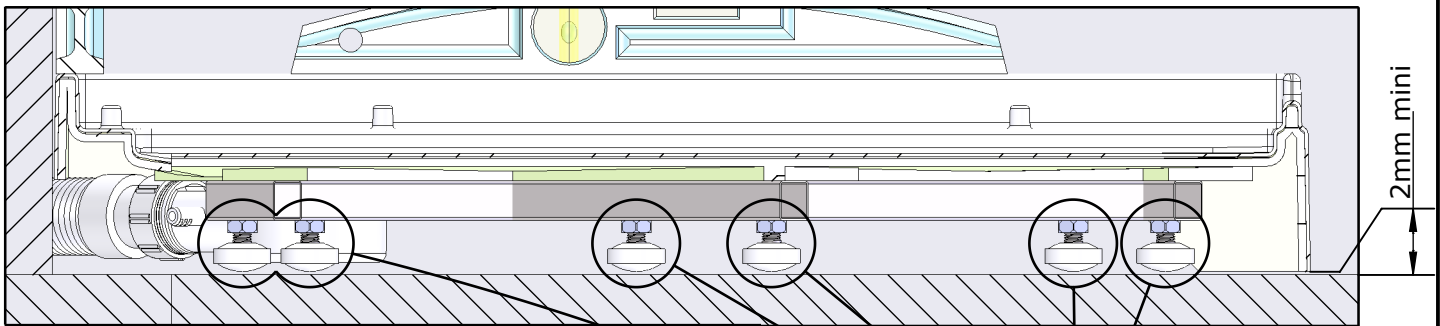

- Pieds en contact avec le sol
- Feet in contact with the ground
- Pies en contacto con el suelo
- Piedi a contatto con il terreno
- Voeten in contact met de grond
- SockelfüÙe im Kontakt mit dem Boden

03

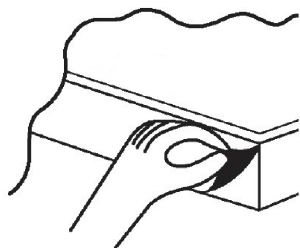
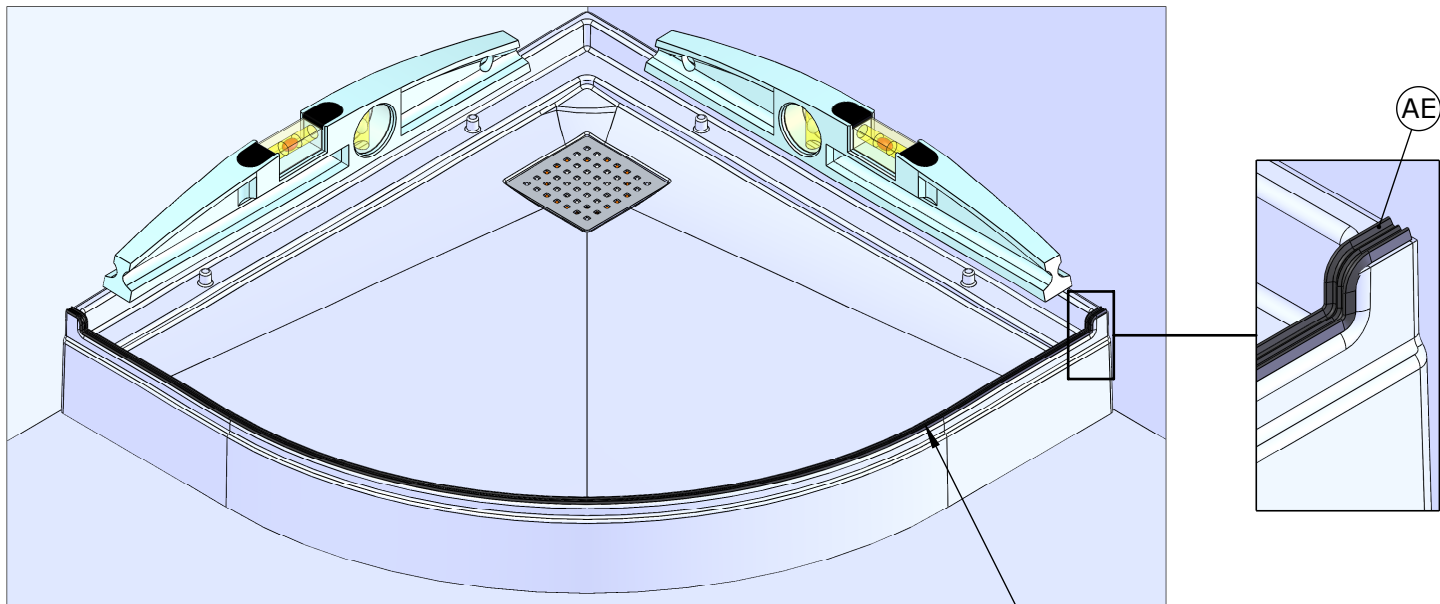

AE

04

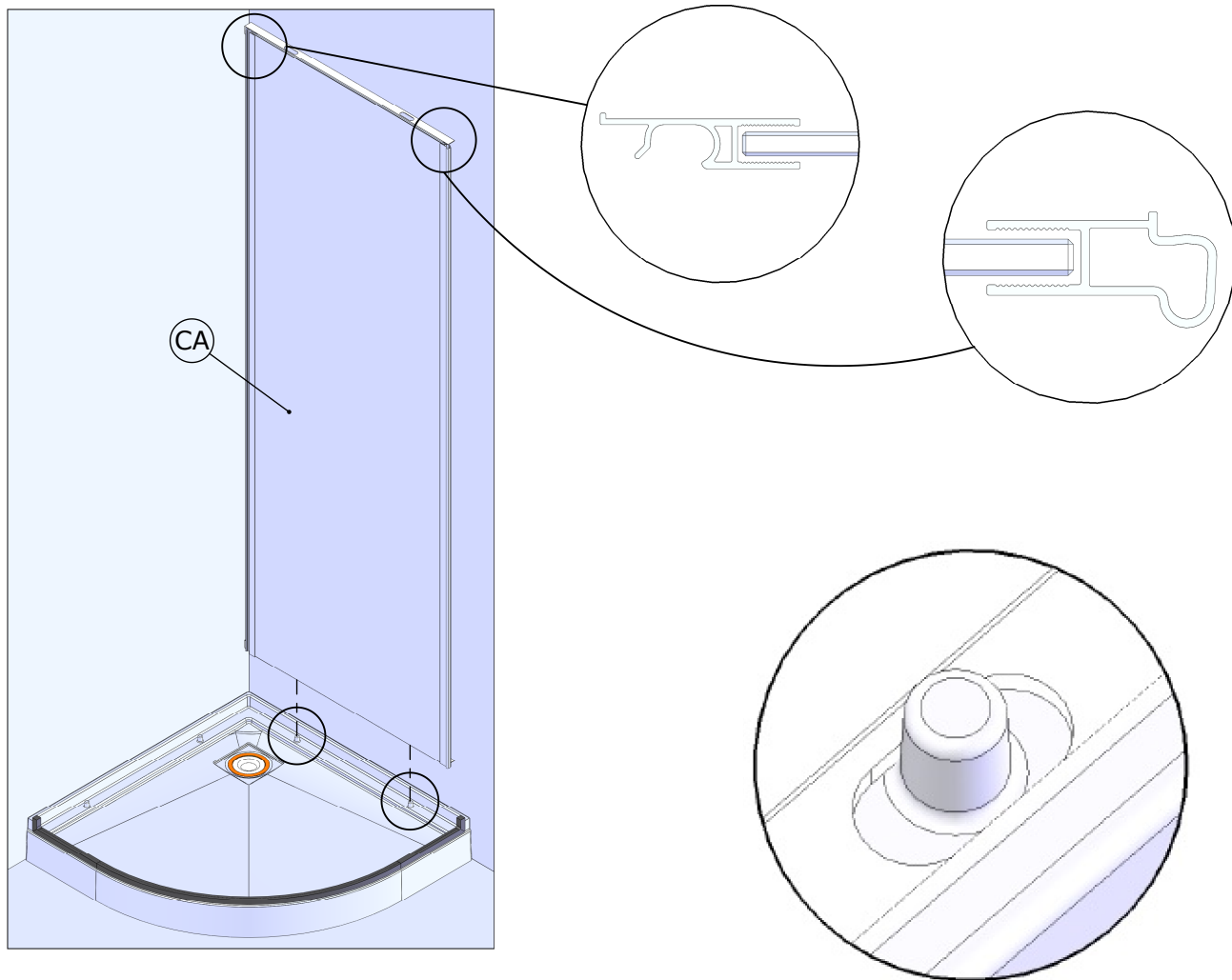

CA

05

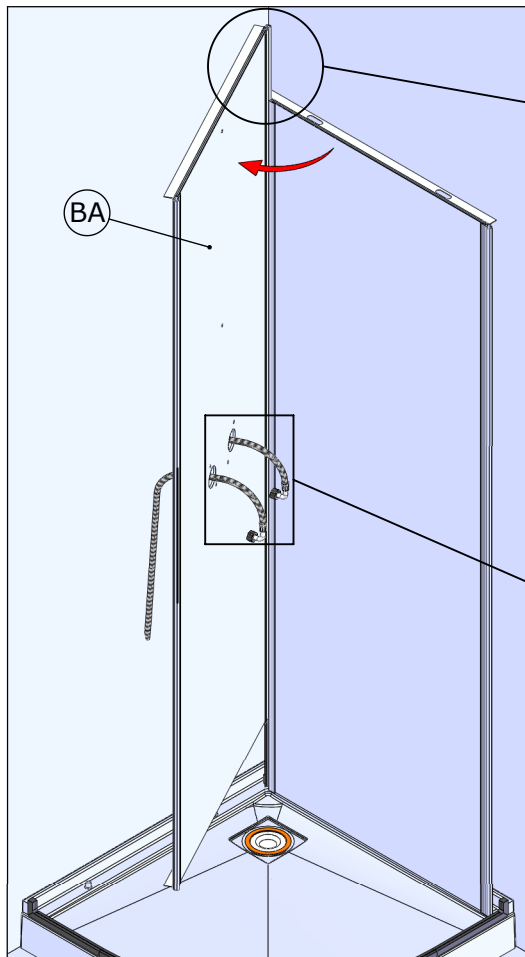

- Raccorder l'arrivée d'eau et la liaison équipotentielle
- Connecting the water inlet and the equipotential link
- Collegare l'ingresso dell'acqua e il collegamento equipotenziale
- Conexión de la entrada de agua y la conexión equipotencial
- Het aansluiten van de watertoevoer en de equipotentiaalverbinding
- Zufluss und Potenzialausgleich anschließen

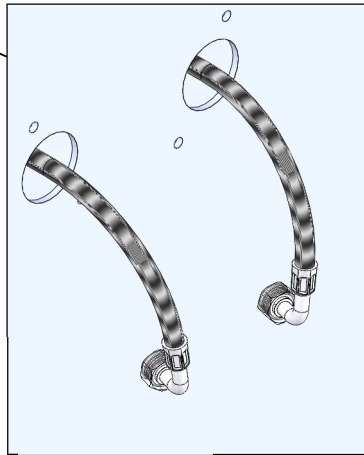

- Passer vos flexibles d'alimentation dans les ouvertures prévues
- Pass your supply hoses in the planned openings
- Pase los flexibles de alimentación en las aperturas previstas
- Passate i tubi flessibili di alimentazione nelle aperture previste
- Geven de flexibele leidingen van voedsel in de voorziene openingen
- Zulaufschläuche durch die vorgesehenen Öffnungen führen

06

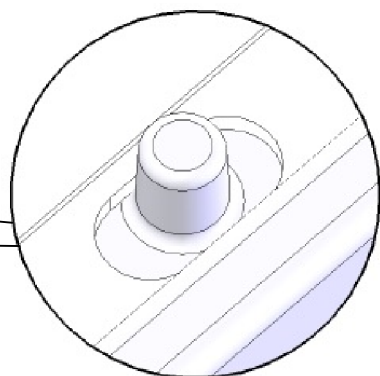
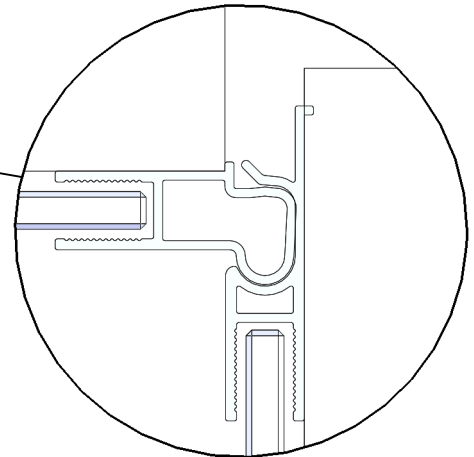
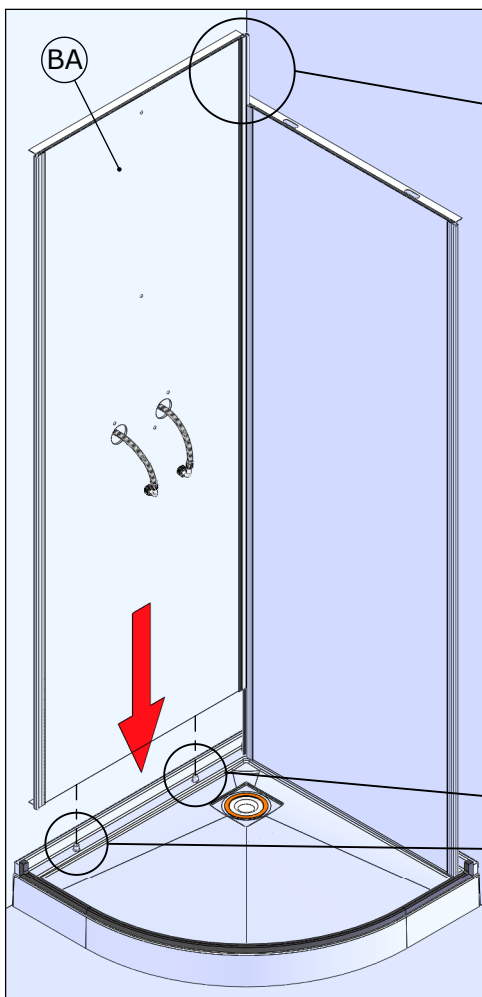

07

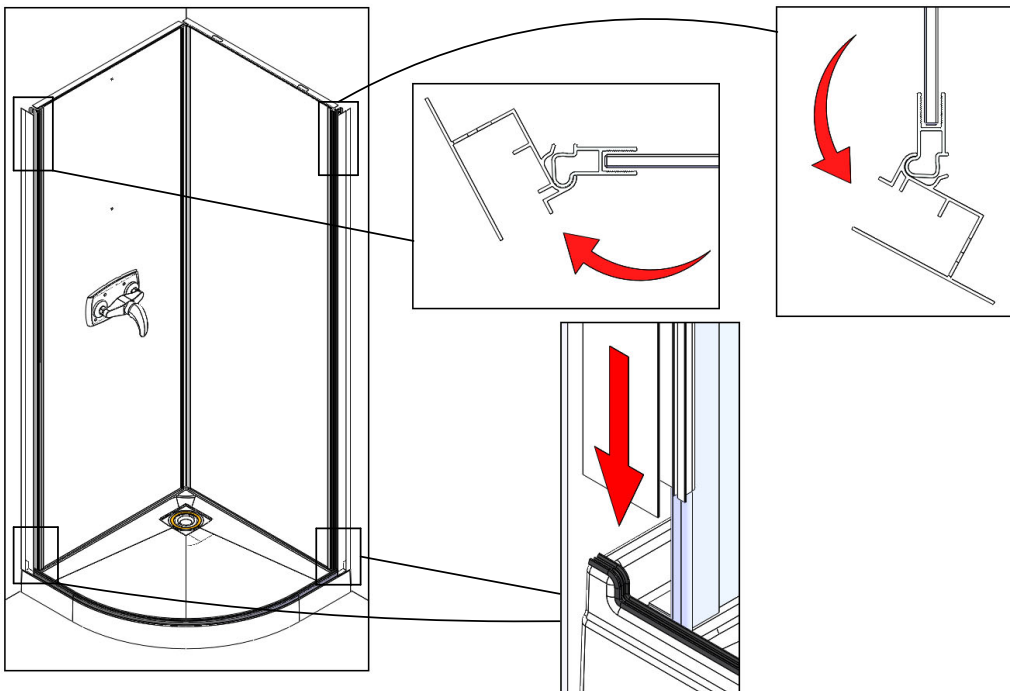

08

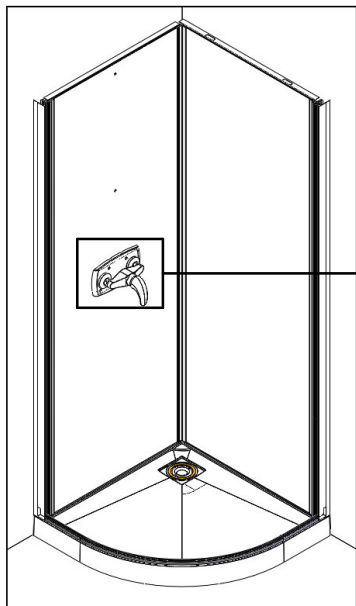

- Raccorder vos flexibles d'alimentation avec votre mitigeur.
- Connect your supply hoses with your mixer.
- Conectar los latiguillos al grifo.
- Raccordare i flessibili di alimentazione al miscelatore.
- Sluit de watertoevoerslangen aan de kraan aan.
- Zulaufschläuche an Mischbatterie anschließen.

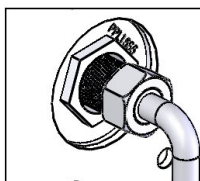
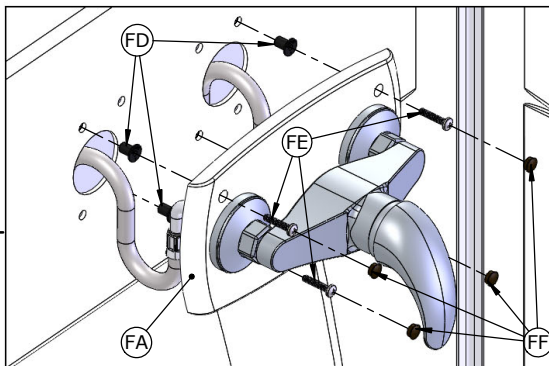

- En fonction de votre version, possibilité mitigeur thermostatique ou pas de mitigeur
- Depending on your version, possibility thermostatic mixer or no mixer
- Según la versión, posibilidad mezclador termostático o no mezclador
- Seconda della versione, possibilità miscelatore termostatico o non miscelatore
- Afhankelijk van de versie, mogelijkheid thermostatische kraan of niet kraan
- Mit oder ohne Mischbatterie, in Abhängigkeit von Ihrer Version

09

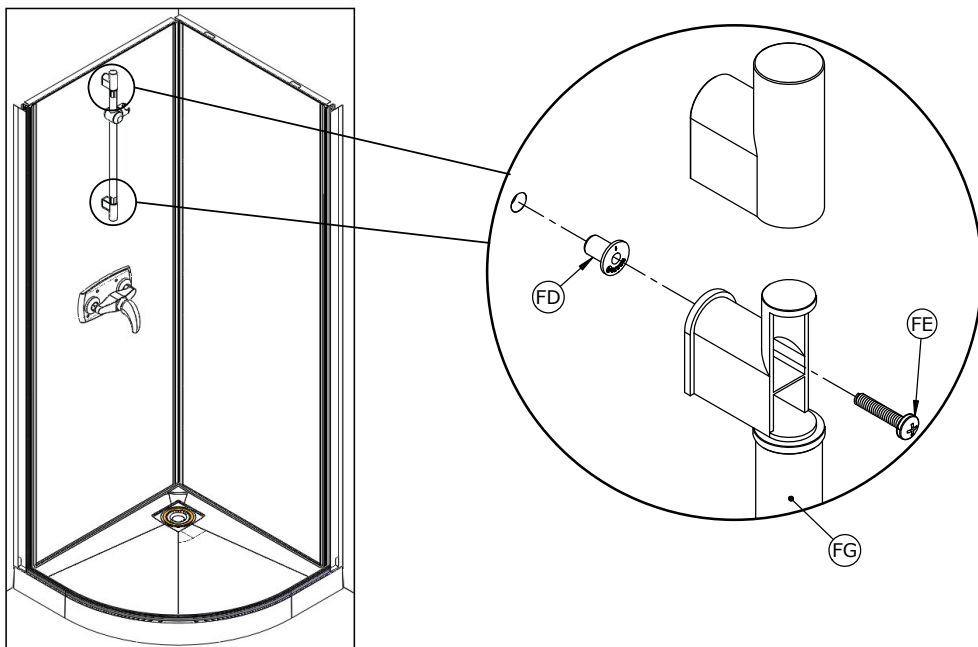

10

FR - En raison du transport et des diverses manipulations du produit, nous vous conseillons vivement de vérifier le bon serrage de chaque connexion, afin d'éviter tout problème de fuite lors de la mise en eau.

EN - Due to transportation and various product handling issues, we strongly recommend that you check that each connection is properly tightened in order to avoid any potential leakage problems when put under pressure.

ES - Debido al transporte y a las distintas manipulaciones del producto, le aconsejamos comprobar que sujeción de cada conexión sea correcta, para evitar los problemas de fuga una vez se conecte con el agua.

IT - A causa del trasporto e delle diverse manipolazioni del prodotto, vi consigliamo vivamente di controllare il buon serraggio di tutti i collegamenti allo scopo di evitare perdite d'acqua.

NL - Door het transport en de diverse logistieke handelingen met het product dient u elke slangconnectie (koppeling/aansluiting) extra te controleren op waterdichtheid alvorens u de douchecabine definitief plaatst. Hiermee vermijdt u mogelijke lekkages nadat het water op druk wordt aangesloten.

D - Nach Transport und Produkt-Handling empfehlen wir Ihnen dringend, jede Verbindung auf Dichtigkeit zu überprüfen, um beim Einlassen des Wassers jegliche Leckagen zu vermeiden.

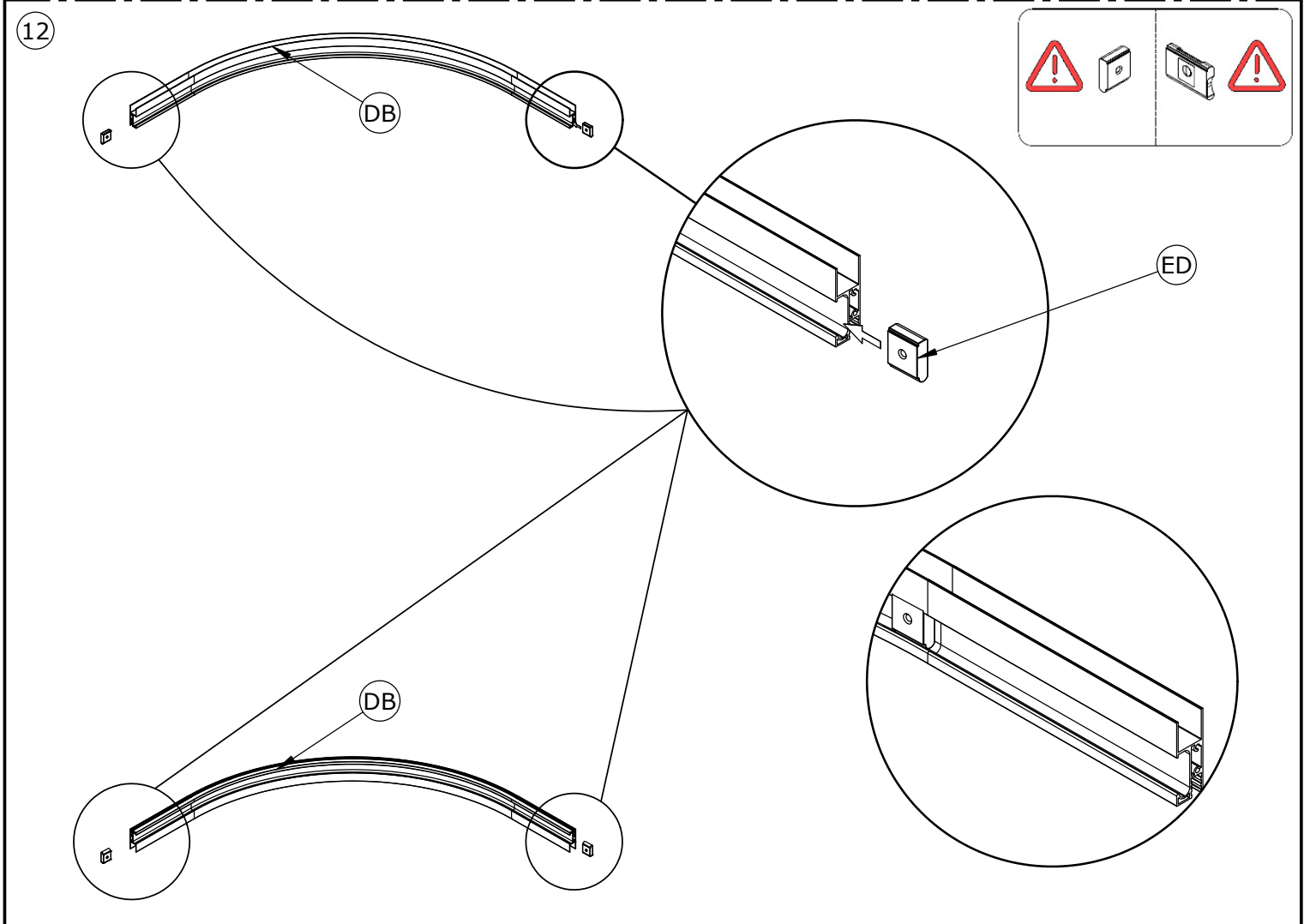
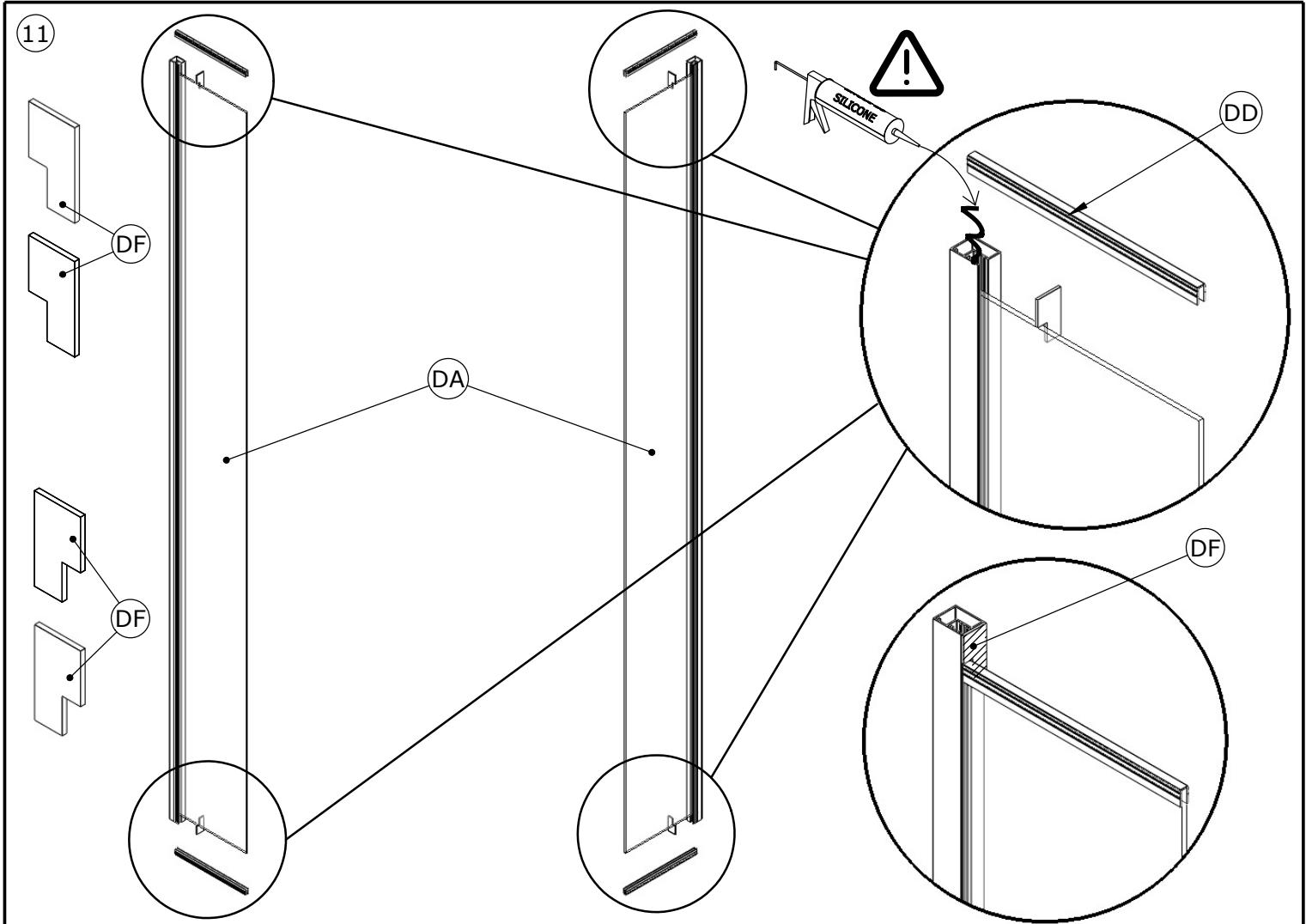

13

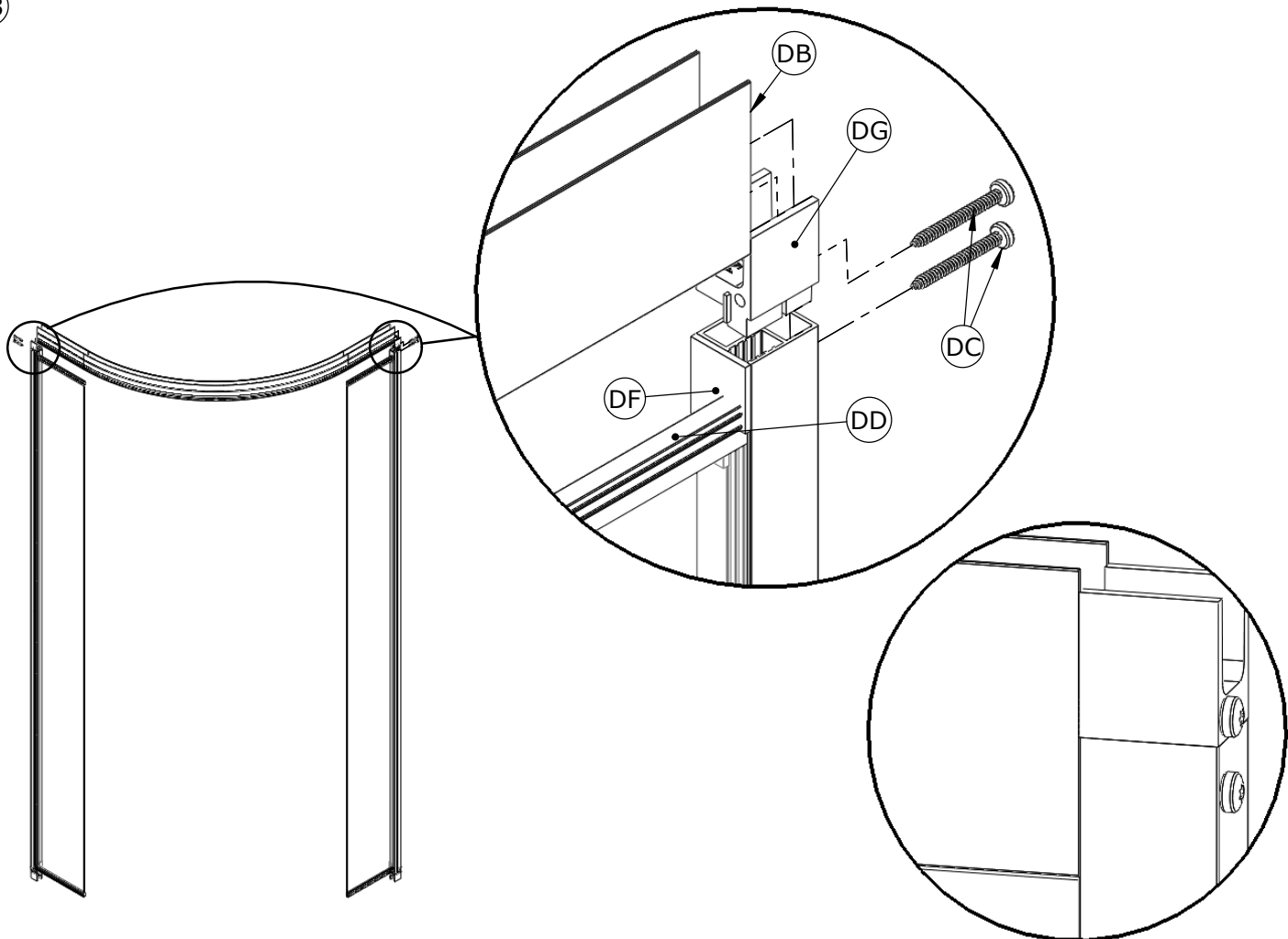

14

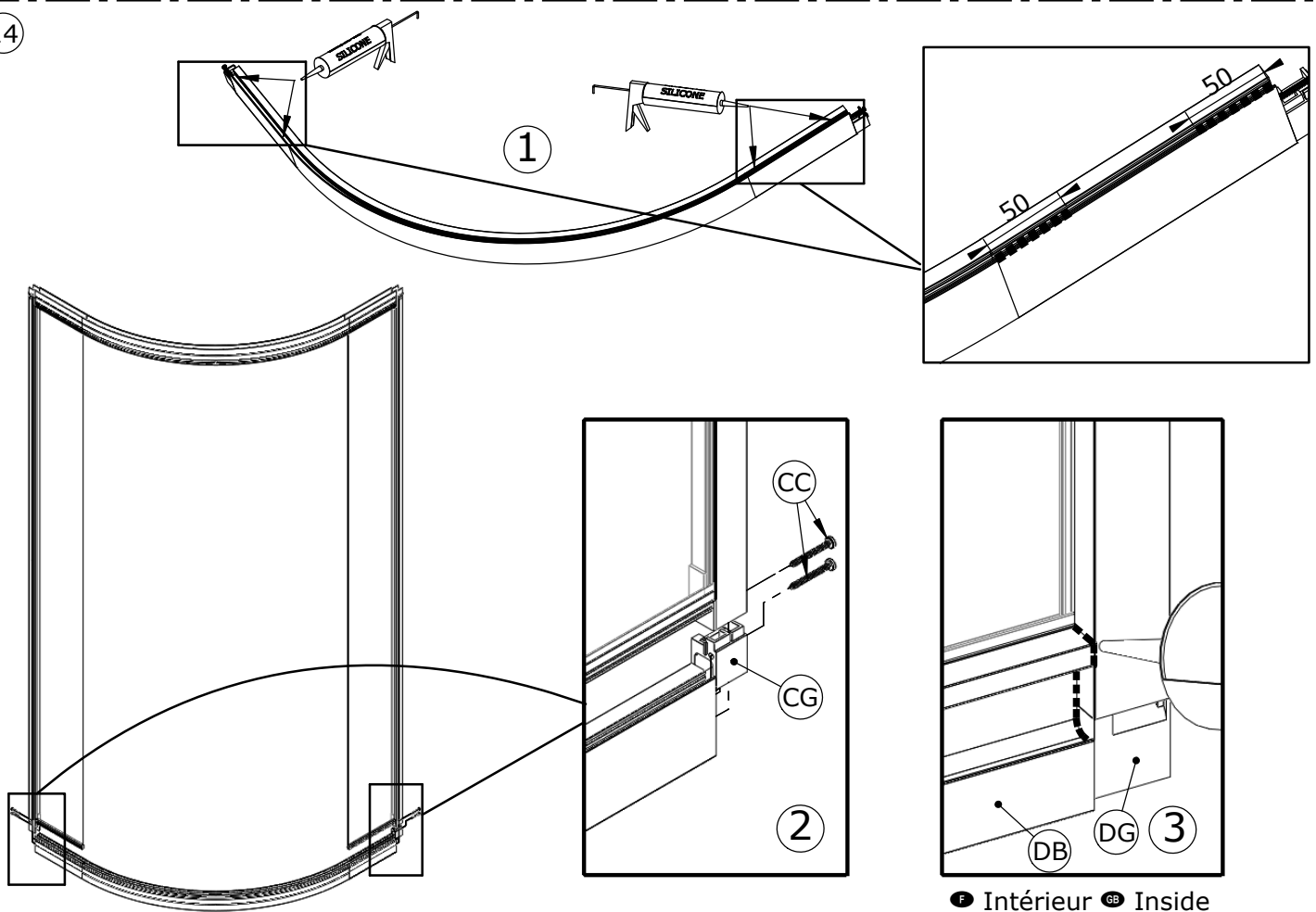

- Intérieur ● GB Inside
- Interno ● Interno
- Binnenkant ● D Innen

13

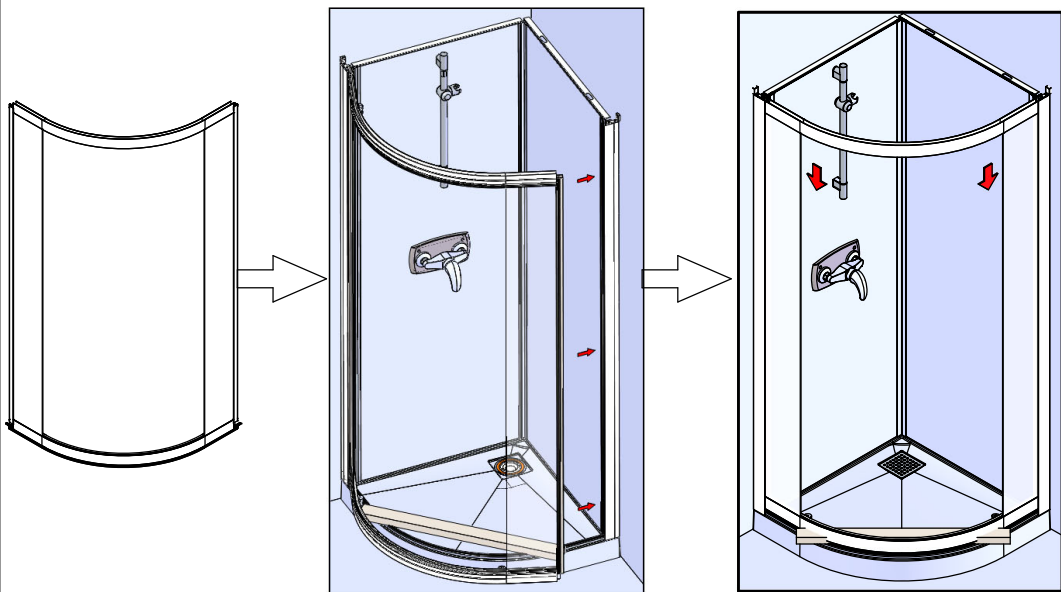

14

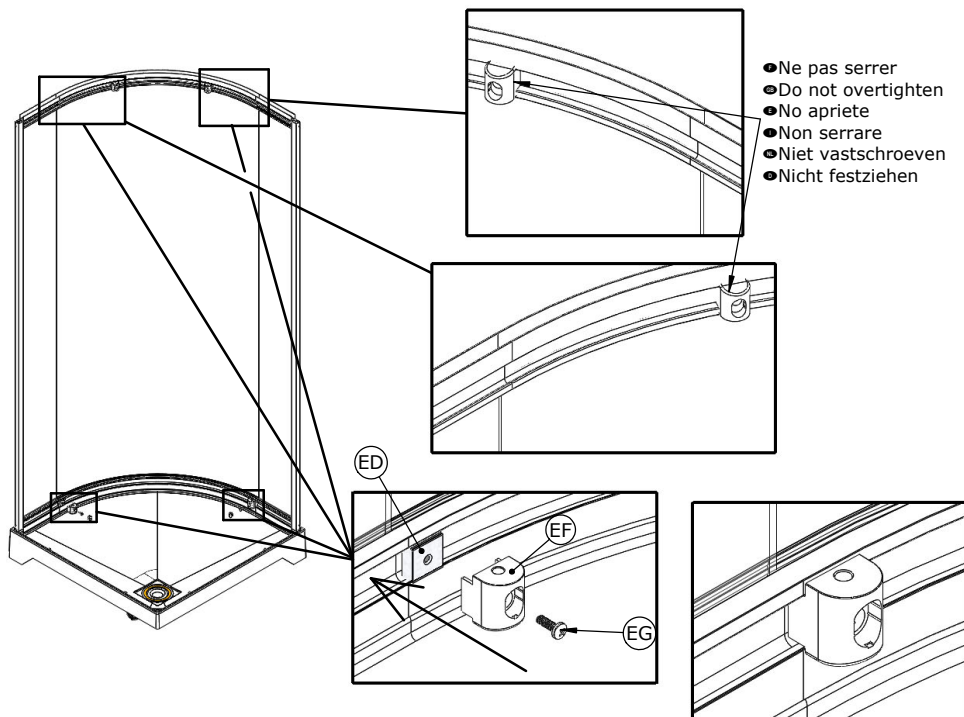

15

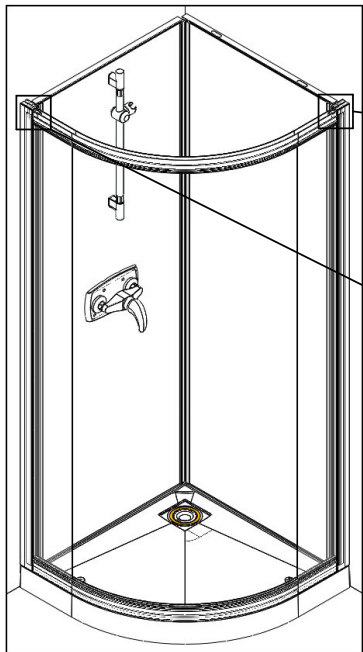

BC

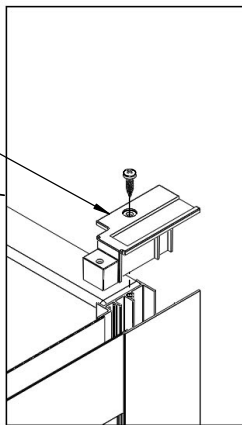

BC

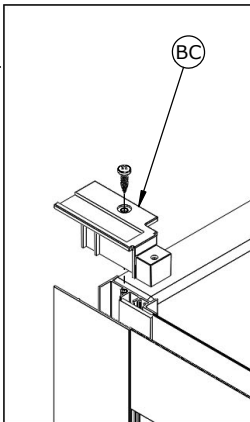

16

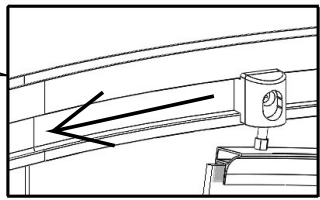
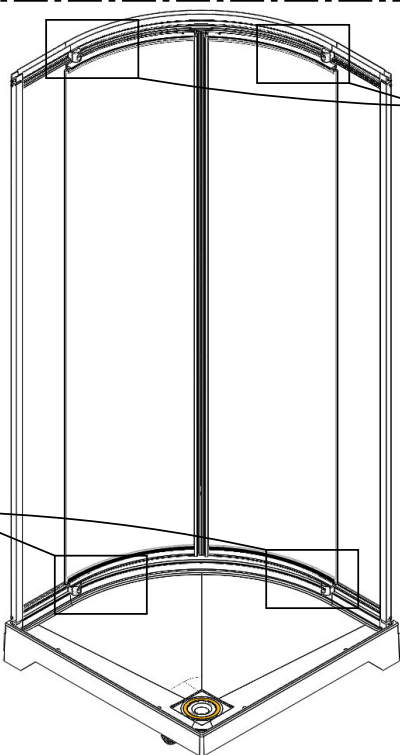

EH

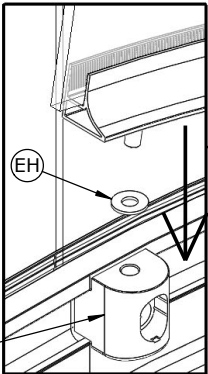

EF

17

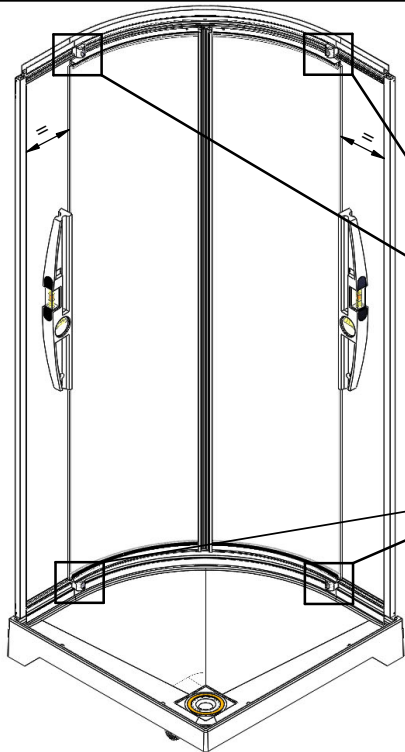

- ① ● Régler les portes afin qu'elles soient centrées et de niveau
 ● Adjust the doors so that they are centered and level
 ● Ajustar las puertas de manera que estén centradas y niveladas
 ● Regolare le porte in modo che siano centrate e in bolla
 ● Stel de deuren zodanig af zodat ze gecentreerd en waterpas staan
 ● Türen zentrieren und waagrecht ausrichten

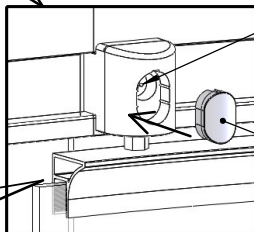

- ② ● Serrer
 ● Tighten
 ● Apriete
 ● Serrare
 ● Vastschroeven
 ● Festziehen

EE

18

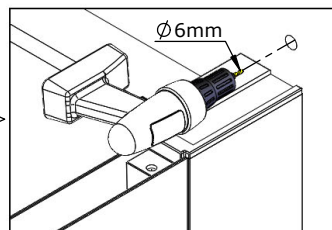
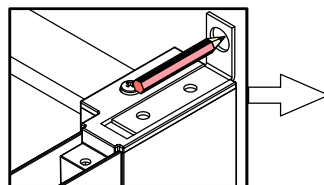
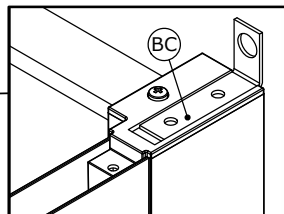
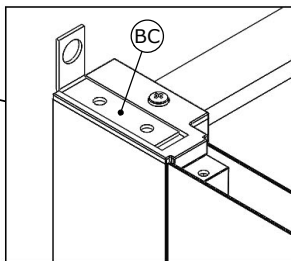
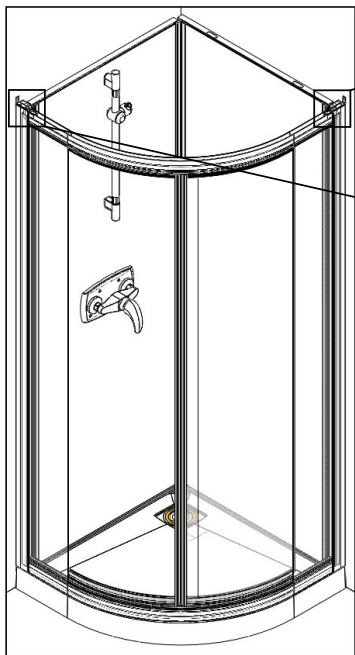

19

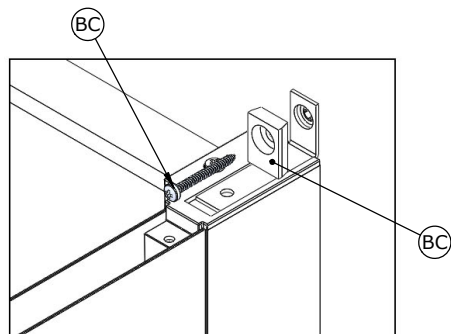
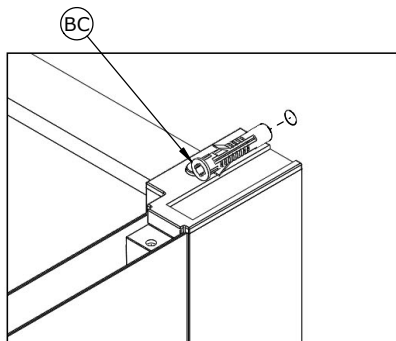
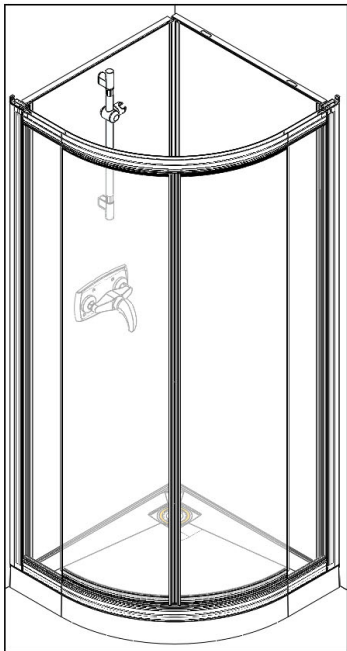

20

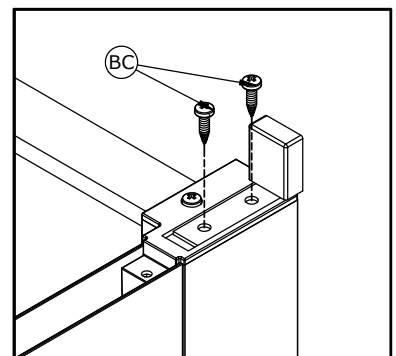
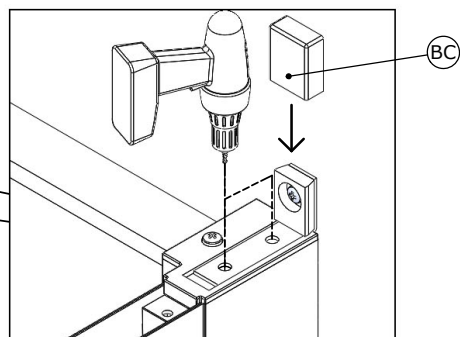
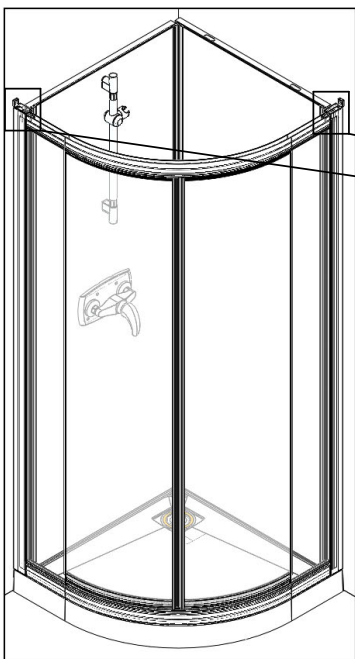

21

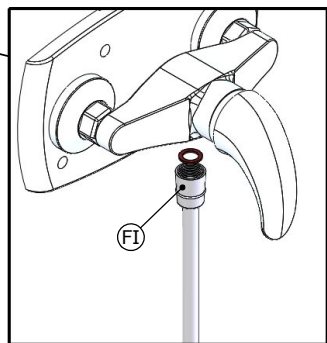
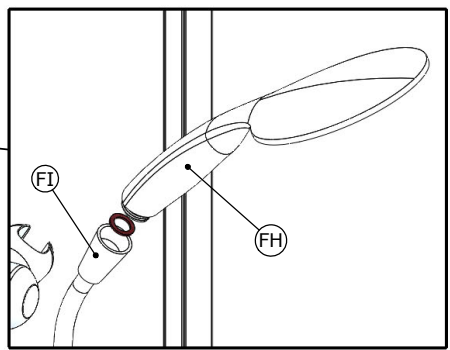
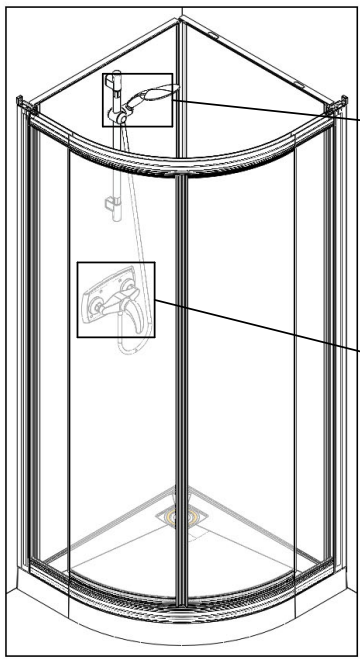

22

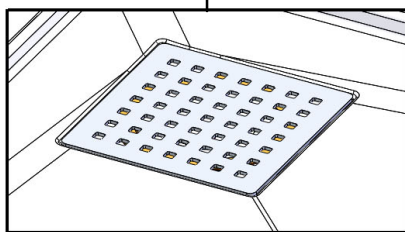
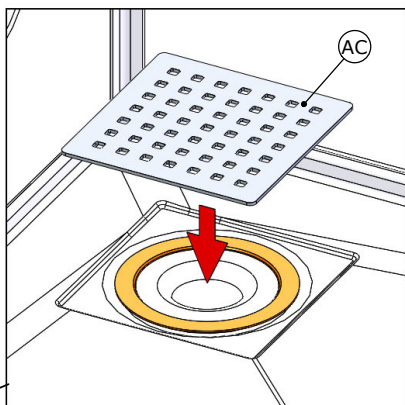
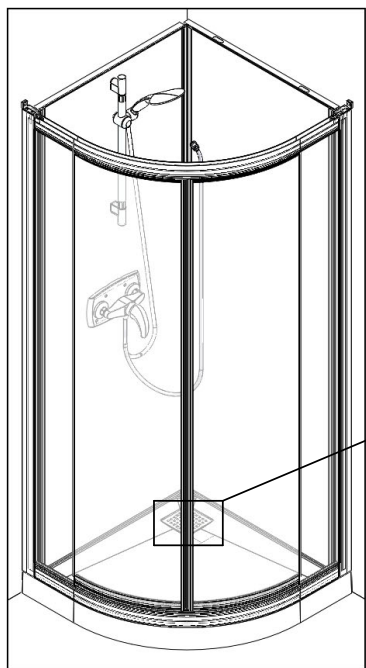

23

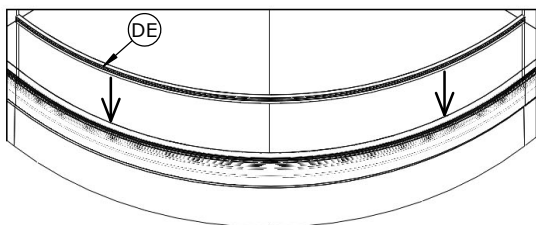
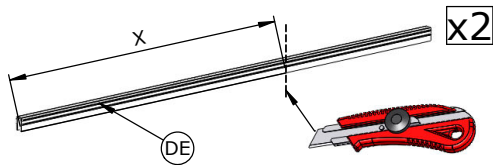
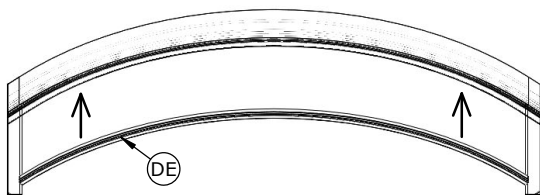
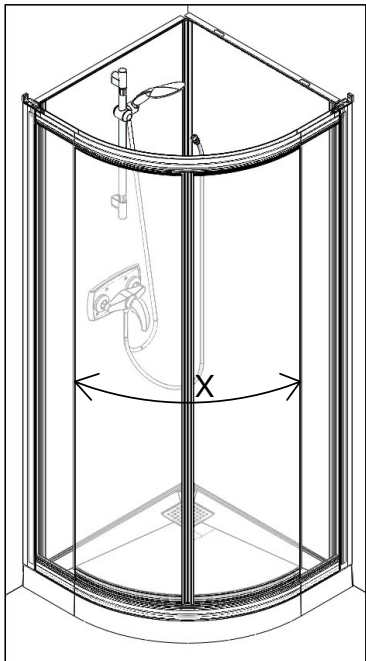

24

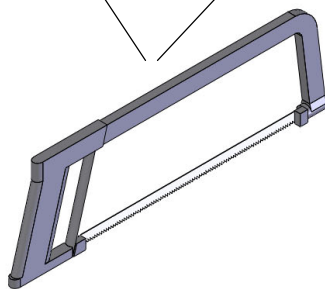
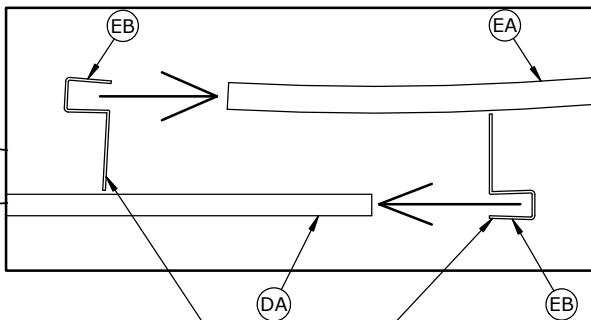
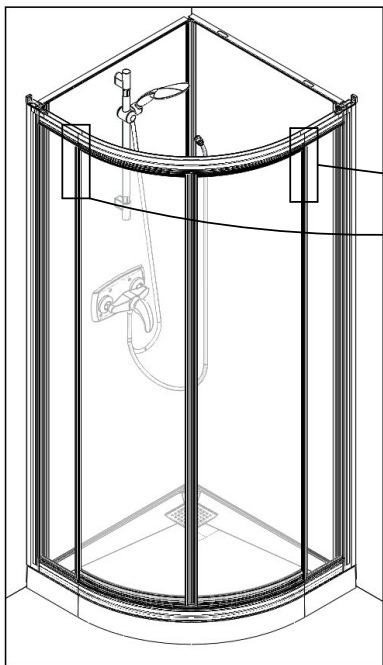



F

POUR LA PROTECTION ELECTRIQUE DE VOTRE DOUCHE, IL EST NECESSAIRE DE RELIER LES ORGANES METALLIQUES DE VOTRE PRODUIT AU CIRCUIT EQUIPOTENTIEL DE VOTRE INSTALLATION.

VOUS POUVEZ CONTACTER VOTRE INSTALLATEUR HABITUEL, IL SAURA VOUS CONSEILLER.

GB

FOR THE ELECTRONIC PROTECTION OF YOUR SHOWER, THE METAL PARTS OF YOUR PRODUCT SHOULD BE CONNECTED TO THE EQUIPOTENTIAL CIRCUIT OF YOUR INSTALLATION.

CONTACT YOUR USUAL SHOWER FITTER FOR ADVICE.

E

PARA LA PROTECCIÓN ELÉCTRICA DE SU DUCHA, SERÁ NECESARIO CONECTAR LOS ELEMENTOS METALICOS DE SU PRODUCTO AL CIRCUITO EQUIPOTENCIAL DE SU INSTALACIÓN.

PÓNGASE EN CONTACTO CON SU INSTALADOR HABITUAL, ÉSTE SABRÁ ACONSEJARLE.

I

PER GARANTIRE LA PROTEZIONE ELETTRICA DELLA DOCCIA OCCORRE COLLEGARE LE PARTI METALLICHE AL CIRCUITO EQUIPOTENZIALE DELL'APPARECCHIO.

CHIEDERE CONSIGLIO ALL'ELETTRICISTA DI FIDUCIA.

NL

VOOR DE ELEKTRISCHE BESCHERMING VAN UW DOUCHE MOETEN DE METALEN DELEN VAN UW PRODUCT WORDEN AANGESLOTEN OP HET EQUIPOTENTIALE CIRCUIT VAN UW INSTALLATIE.

NEEM HIERVOOR CONTACT OP MET UW NORMALE INSTALLATEUR, HIJ KAN U ADVISEREN.

D

FÜR DEN ELEKTRISCHEN SCHUTZ IHRER DUSCHE IST ES ERFORDERLICH, DIE METALLELEMENTE IHRES PRODUKTS MIT DEM ÄQUIPOZENTIALSCHALTkreis IHRES INSTALLATEURS ZU VERBINDEN.

NEHMEN SIE DIESBEZÜGLICH GGF. KOMTAKT MIT IHREM HAUSINTALLATEUR AUF UND LASSEN SIE SICH BERATEN.



SAV
SERVICE HELPLINES
ASSISTENZA POST-VENDITA
SERVICIO POSTVENTA

FRANCE

02 40 21 29 45

SCHWEIZ

(01) 748 17 44

UK

020 8842 0033

ESPANA

93 544 60 76

IRELAND

04697 33102

NEDERLAND

+31 475 487 100

DEUTSCHLAND

+49 (0) 6074 / 30928 0

BELGIE

+31 475 487 100

ITALIA

(0382) 6181

BELGIQUE

+31 475 487 100

OSTEREICH

+43 1 710 60 70

РОССИЯ

963 19 40, 773 67 22