

**NOTICE DE MONTAGE (VERSION PIVOTANTE)
INSTALLATION INSTRUCTIONS (PIVOTING VERSION)
MANUAL DE INSTALACION (VERSION PIVOTANTE)
ISTRUZIONI DI MONTAGGIO (VERSIONE GIREVOLE)
INSTALLATIE VOORSCHRIFTEN (DRAAIBARE VERSIE)**

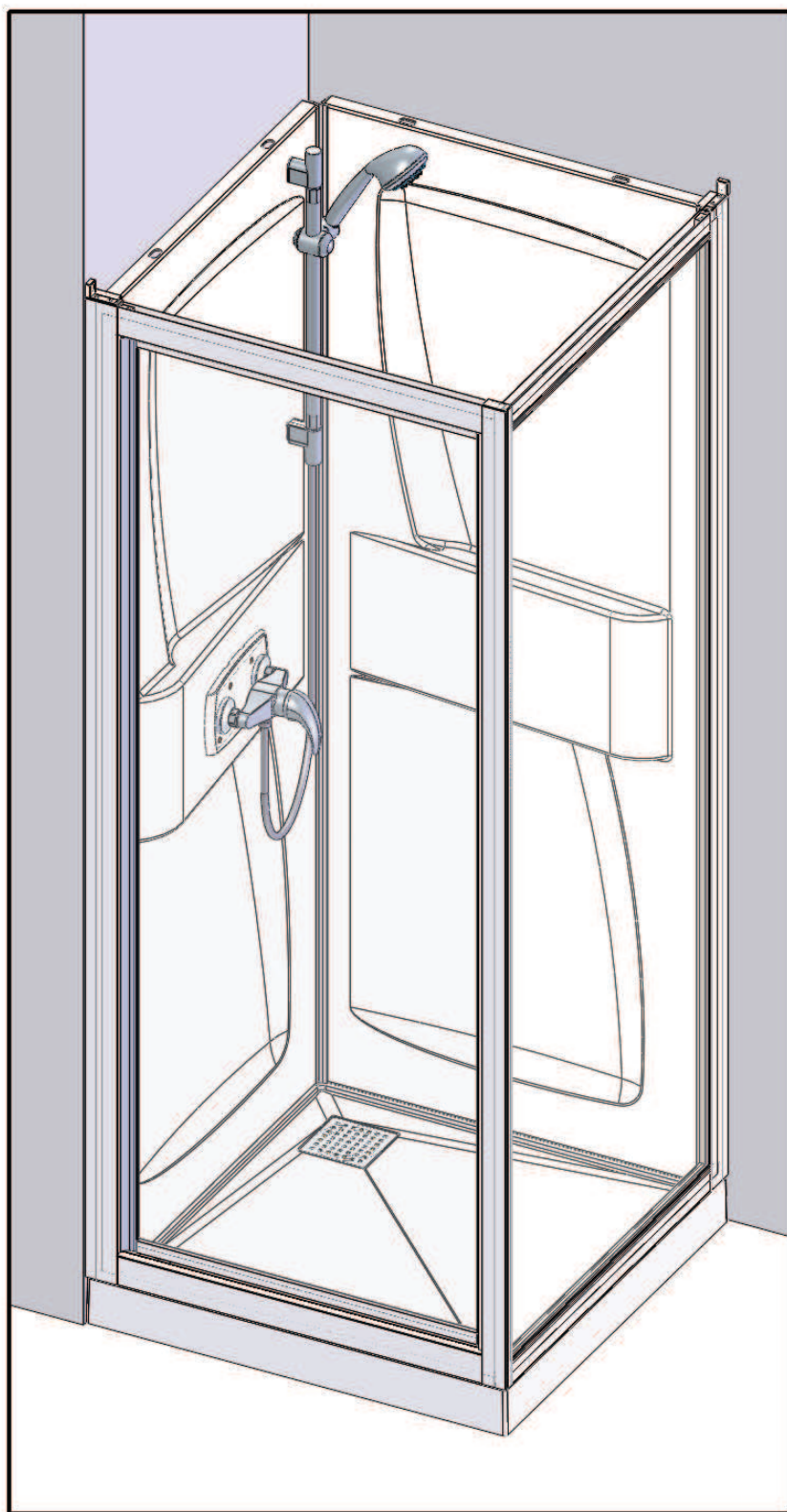

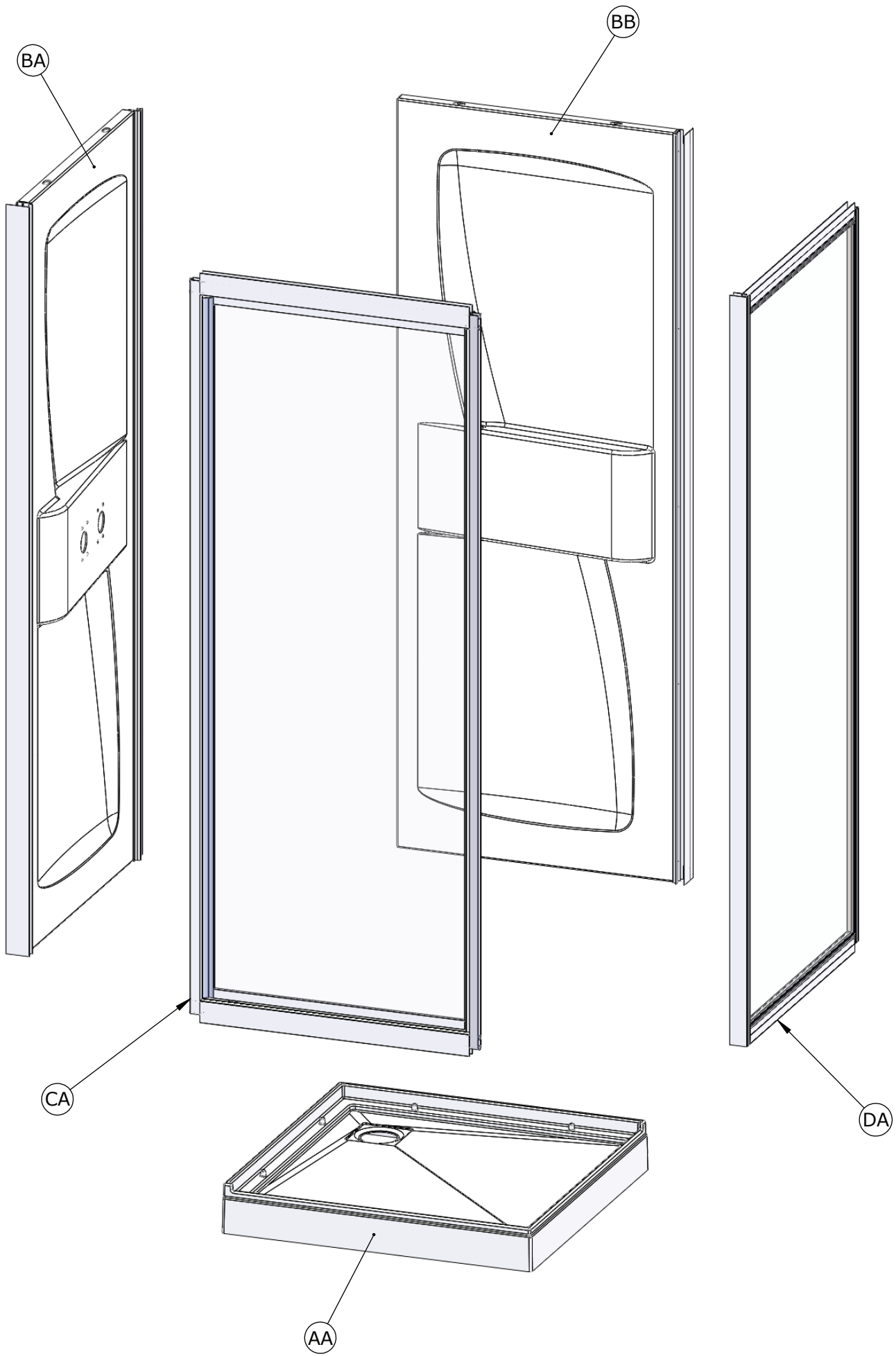

PIECES DETACHEES / SPARE PARTS / ONDERDELEN

Rep	70 x 70		80 x 80		90 x 90		100 x 80		Qté
	BAS/LOW	HAUT/HIGH	BAS/LOW	HAUT/HIGH	BAS/LOW	HAUT/HIGH	BAS/LOW	HAUT/HIGH	

COLIS 1									
AA	REC417	REC423	REC418	REC424	REC419	REC425	REC420	REC426	1
AB	BOND14								1
AC	TOL54								1
AD	SV028								1
AE	J547								3

COLIS 2					
BA + BB	CP846	CP847	CP848	CP849	1
BC	PPL776				2
BD	VIS41				2
BE	PPL775				2
BF	EQU68				2
BG	CHE02				2
BH	VIS 3,5x25				6
BI	PPL737				1
BJ	PPL738				1
BK	PPL735				1
BL	PPL736				1

COLIS 3						
CA	TN	C8360	C8361	C8362	C8363	1
	DT	C8364	C8365	C8366	C8367	1
CB		JOI179				1

COLIS 4						
DA	TN	C8370	C8371	C8372	C8371	1
	DT	C8373	C8374	C8375	C8374	1
DB		PPL739				1
DC		PPL740				1

BOITE				
EA	SANS Mitigeur	SET48		1
	Mitigeur MECA	SET50		1
	Mitigeur THERMO	SET51		1
EB		TUY60		1
EC		TUY61		1
ED		ECR72		6
EE		VIS200		6
EF		CAP18		4
EG		KIT109		1

Colis 1

S1552

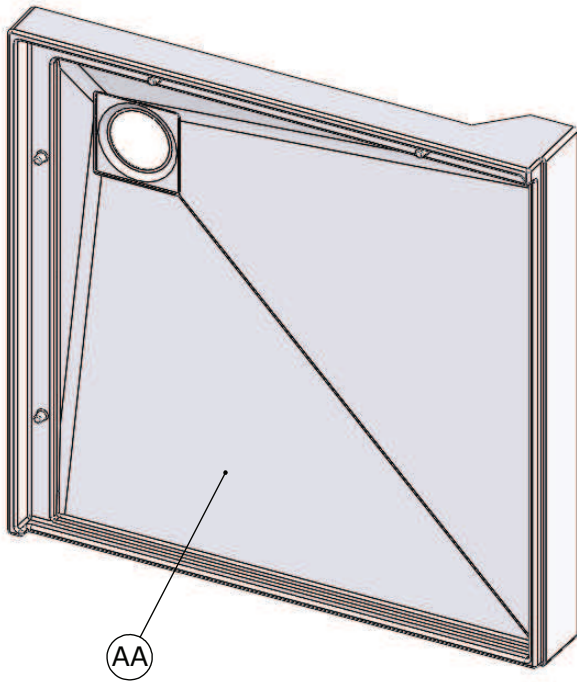

+

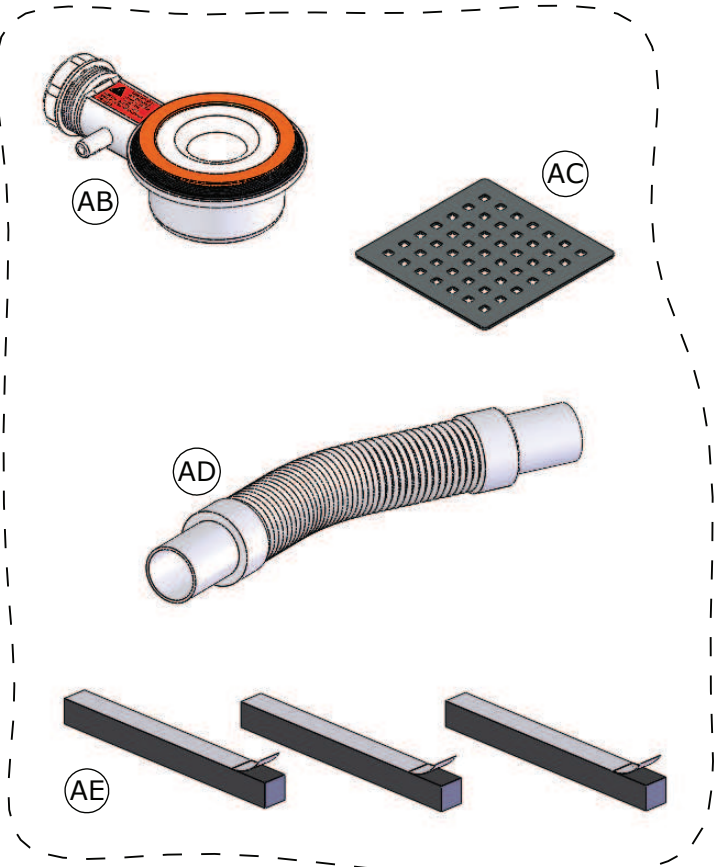

Colis 2

S1555

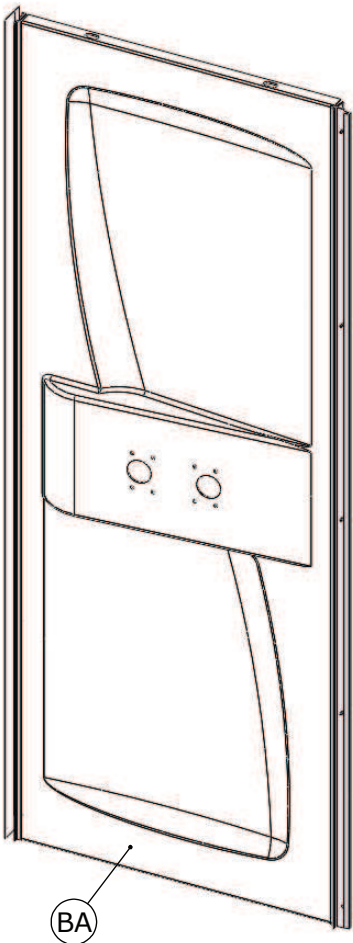

+

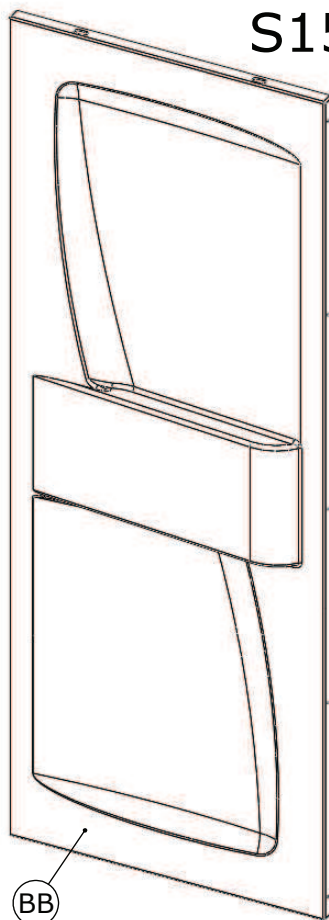

+

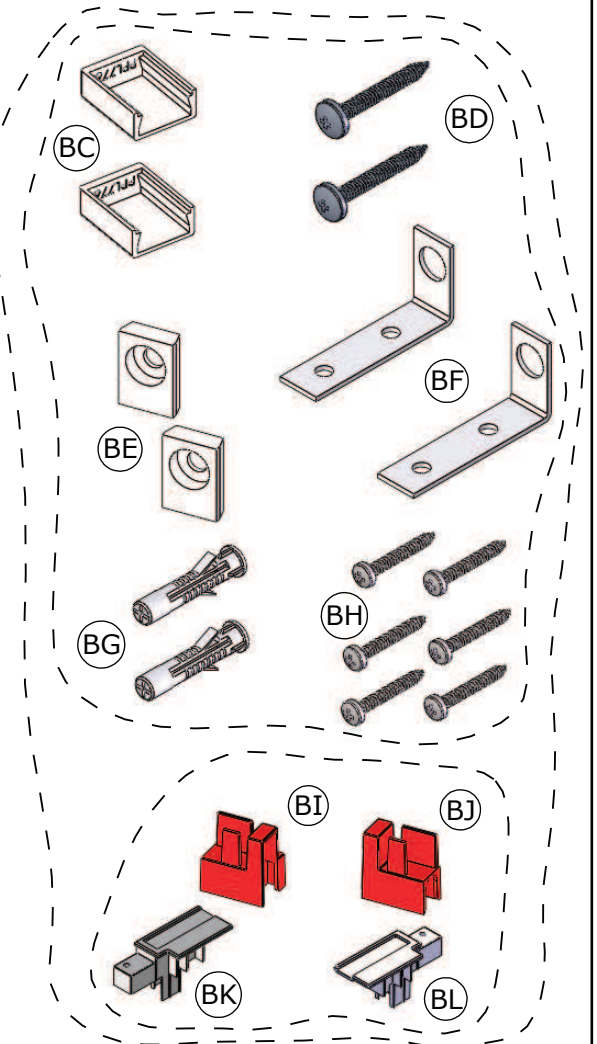

Colis 3

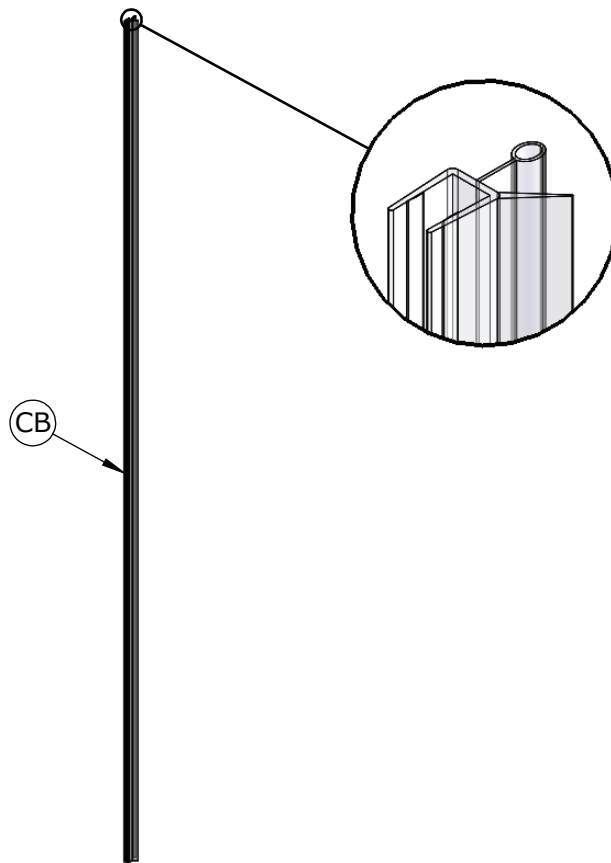
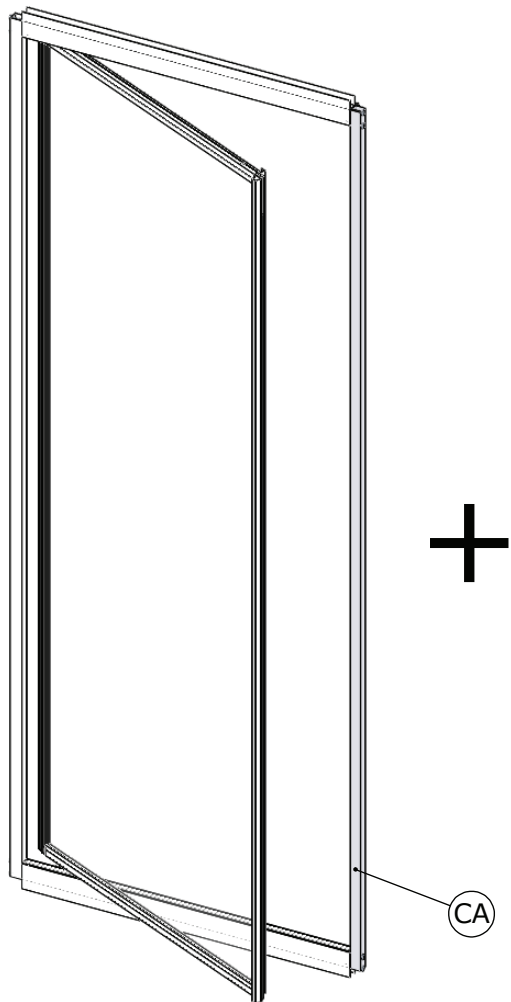

Colis 4

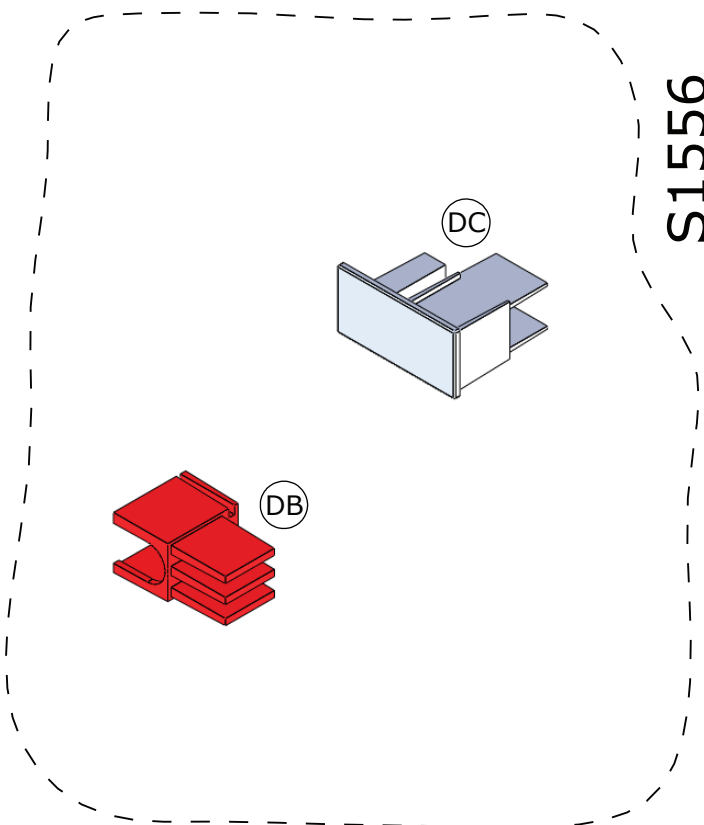
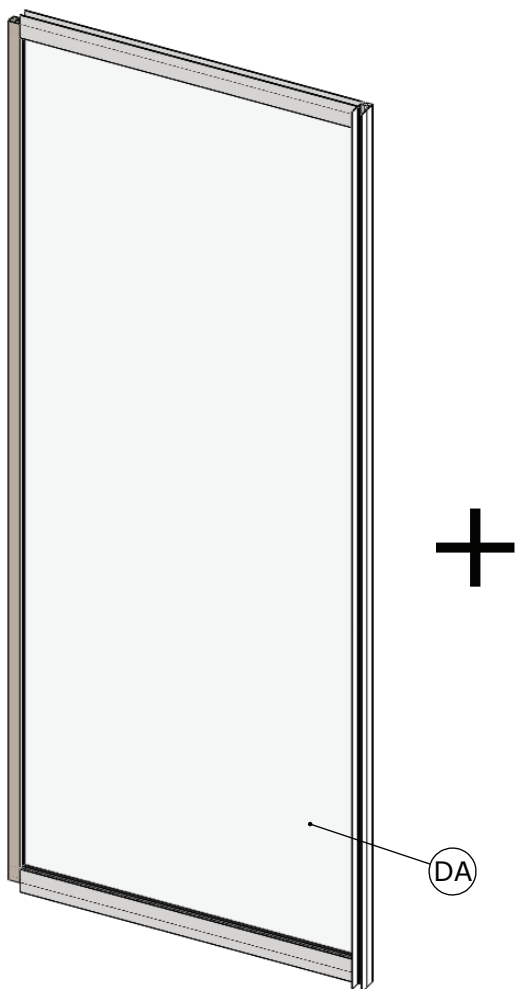

BOITE

Mitigeur MECA

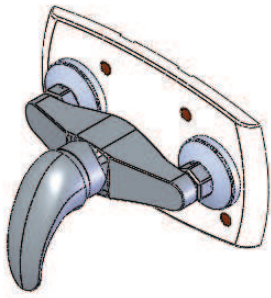

OU

Mitigeur THERMO

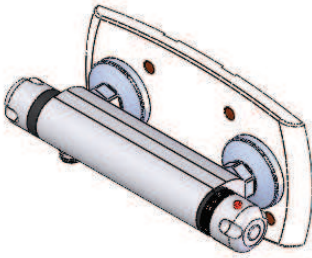

OU

SANS Mitigeur

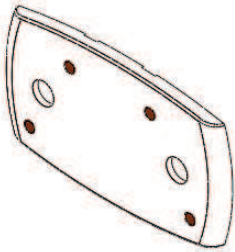

EA

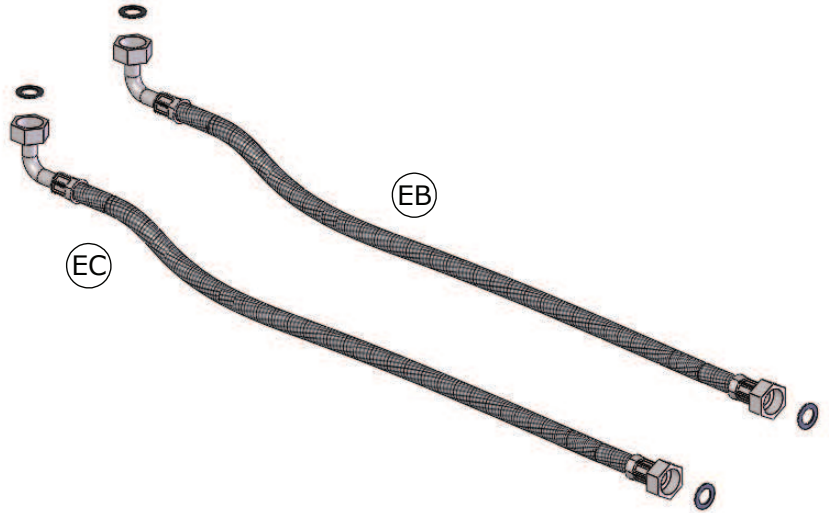

EC

EB

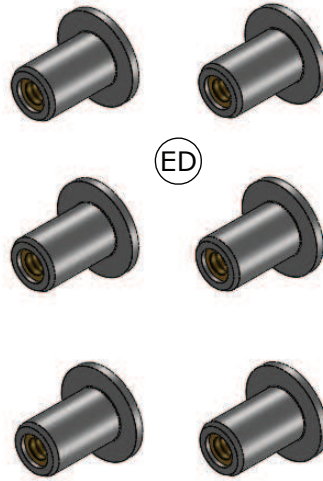

ED

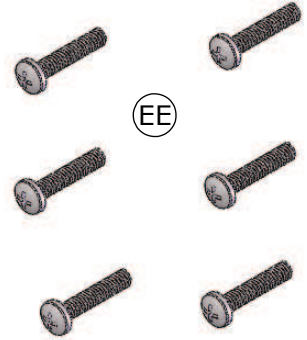

EE

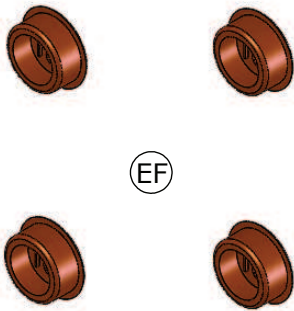

EF

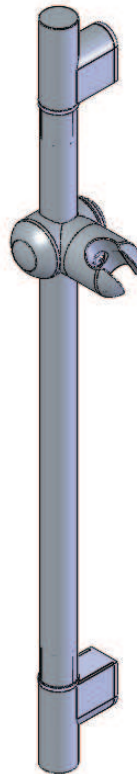

EG

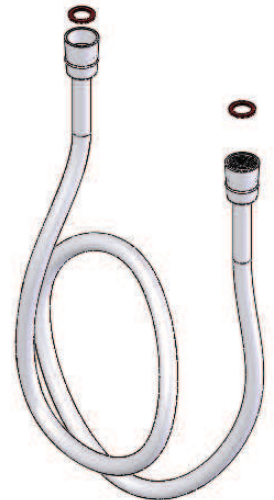

● Matériel nécessaire ● Tools required ● Herramientas necesarias
 ● Materiale necessario ● Benodigd gereedschap

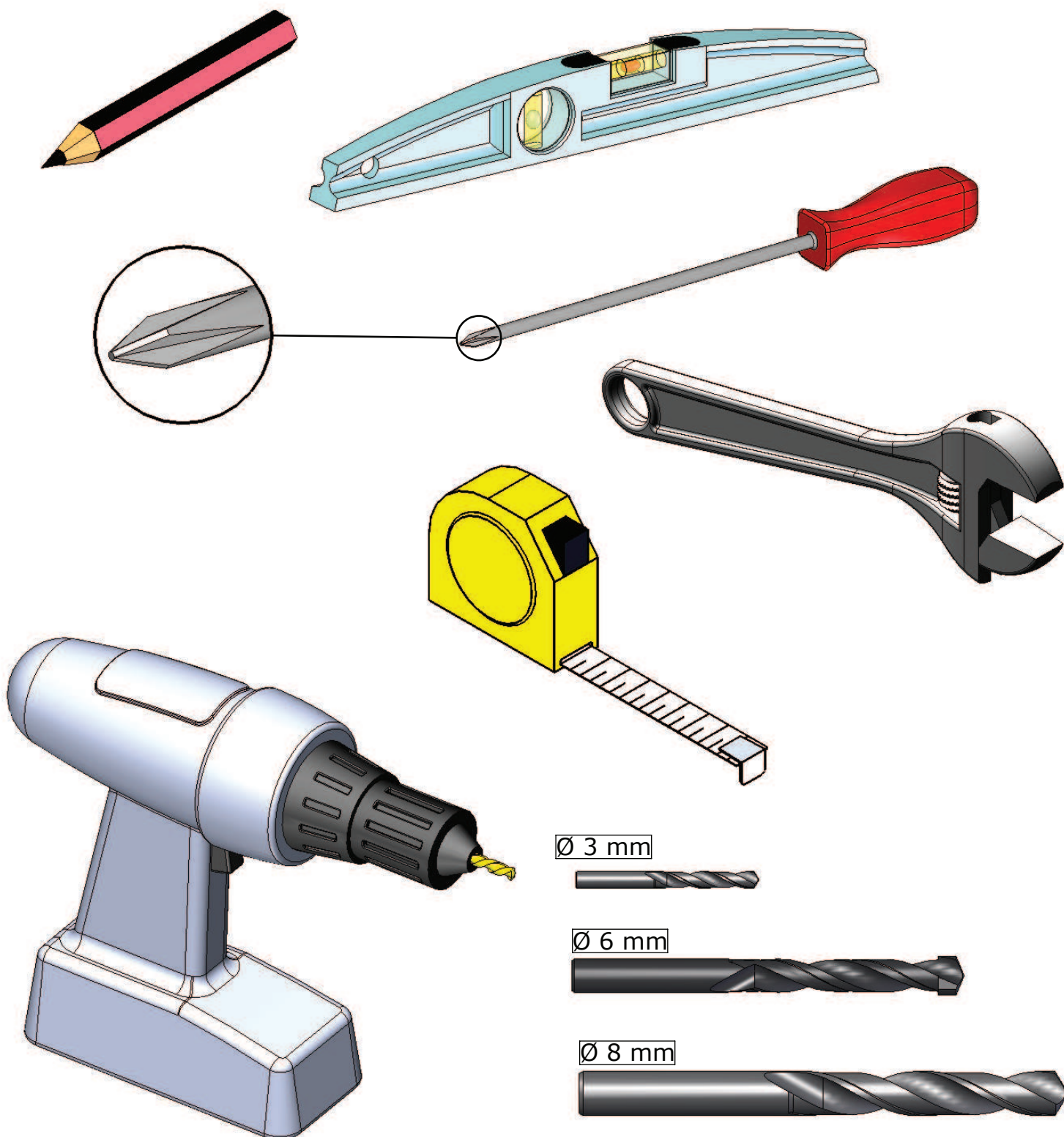

F REVERSIBILITE **GB** REVERSIBILITY **E** REVERSIBILIDAD
I REVERSIBILITA **NL** OMKEERBAARHEID

F MONTAGE A GAUCHE
GB LEFT HAND
E MONTAJE A LA IZQUIERDA
I MONTAGGIO A SINISTRA
NL MONTAGE LINKS

F MONTAGE A DROITE
GB RIGHT HAND
E MONTAJE A LA DERECHA
I MONTAGGIO A DESTRA
NL MONTAGE RECHTS

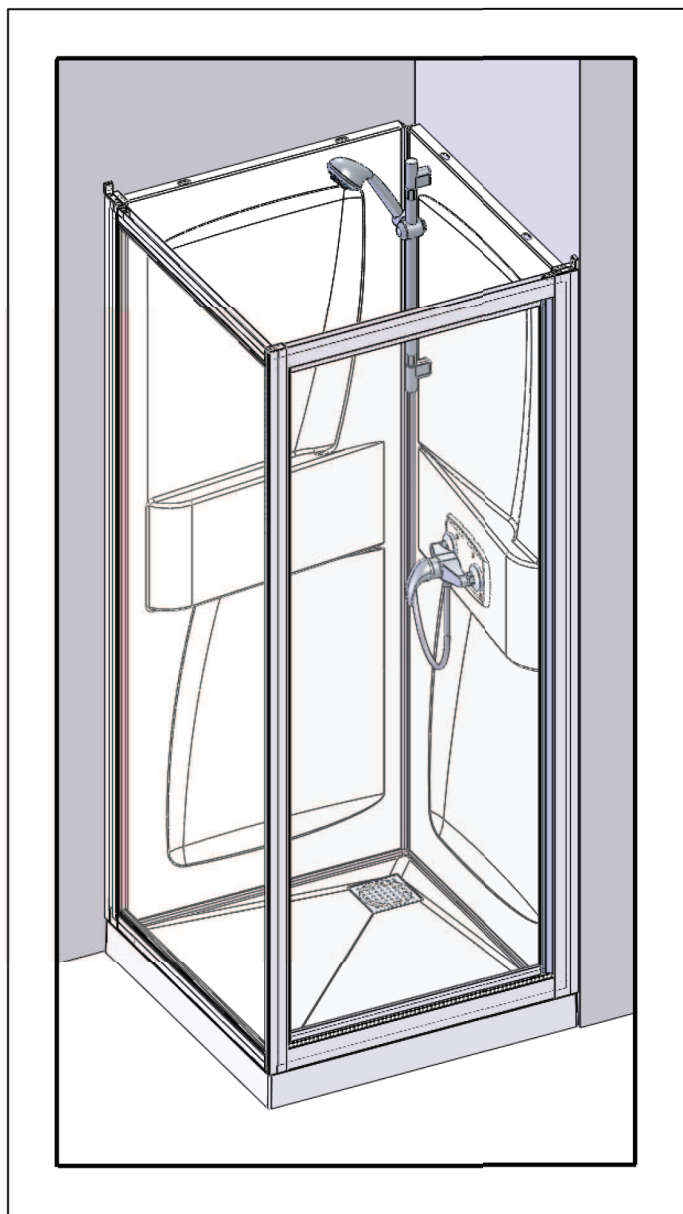
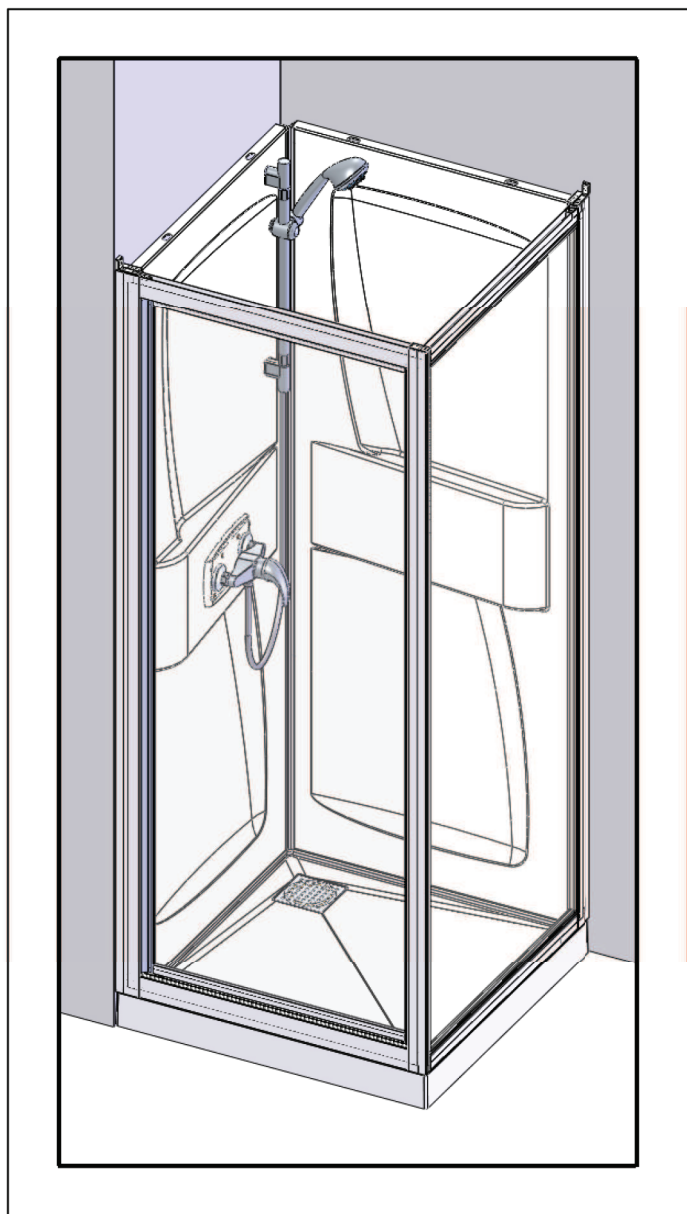

F Vous avez la possibilité de réaliser un montage à droite ou un montage à gauche. Notre notice d'installation décrit un montage à gauche. Si vous voulez réaliser un montage à droite, il vous suffit d'inverser le montage.

GB This cubicle can be installed either left or right hand. These installation instructions show a left hand installation.

E Puede realizar un montaje a la derecha o un montaje a la izquierda. Nuestro folleto de instalación describe un montaje a la izquierda. Si desea montar su cabina a la derecha sólo tendrá que realizar el montaje al contrario.

I Avete la possibilità di effettuare il montaggio a destra o a sinistra. Il nostro manuale descrive il montaggio a sinistra. Se volete realizzare il montaggio a destra è sufficiente invertire varie fasi di montaggio.

NL U kunt de douchecabine rechts of links monteren. Onze handleiding beschrijft de links montage van de cabine. Keer de montage om als u de cabine rechts wilt monteren.

01

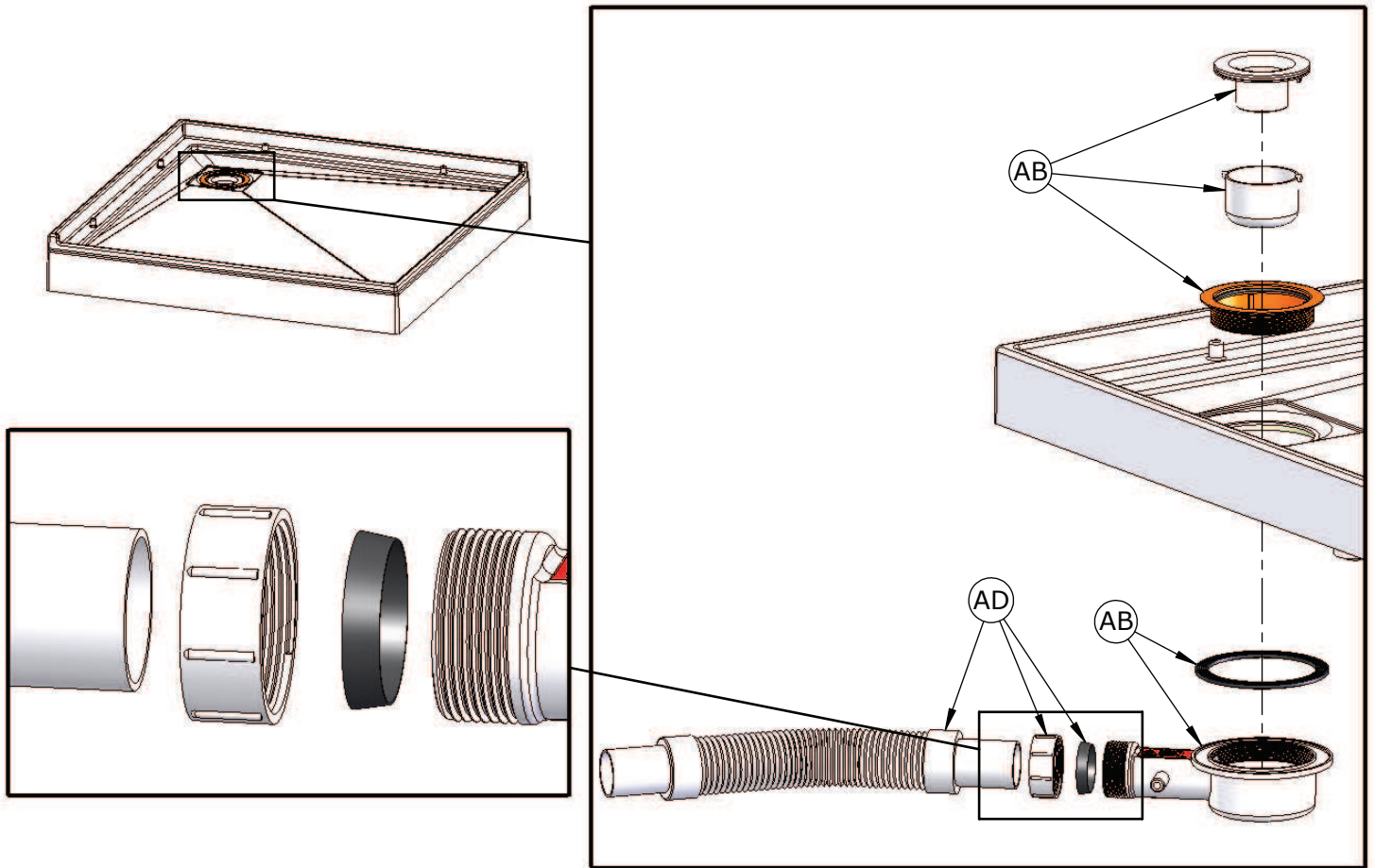

02

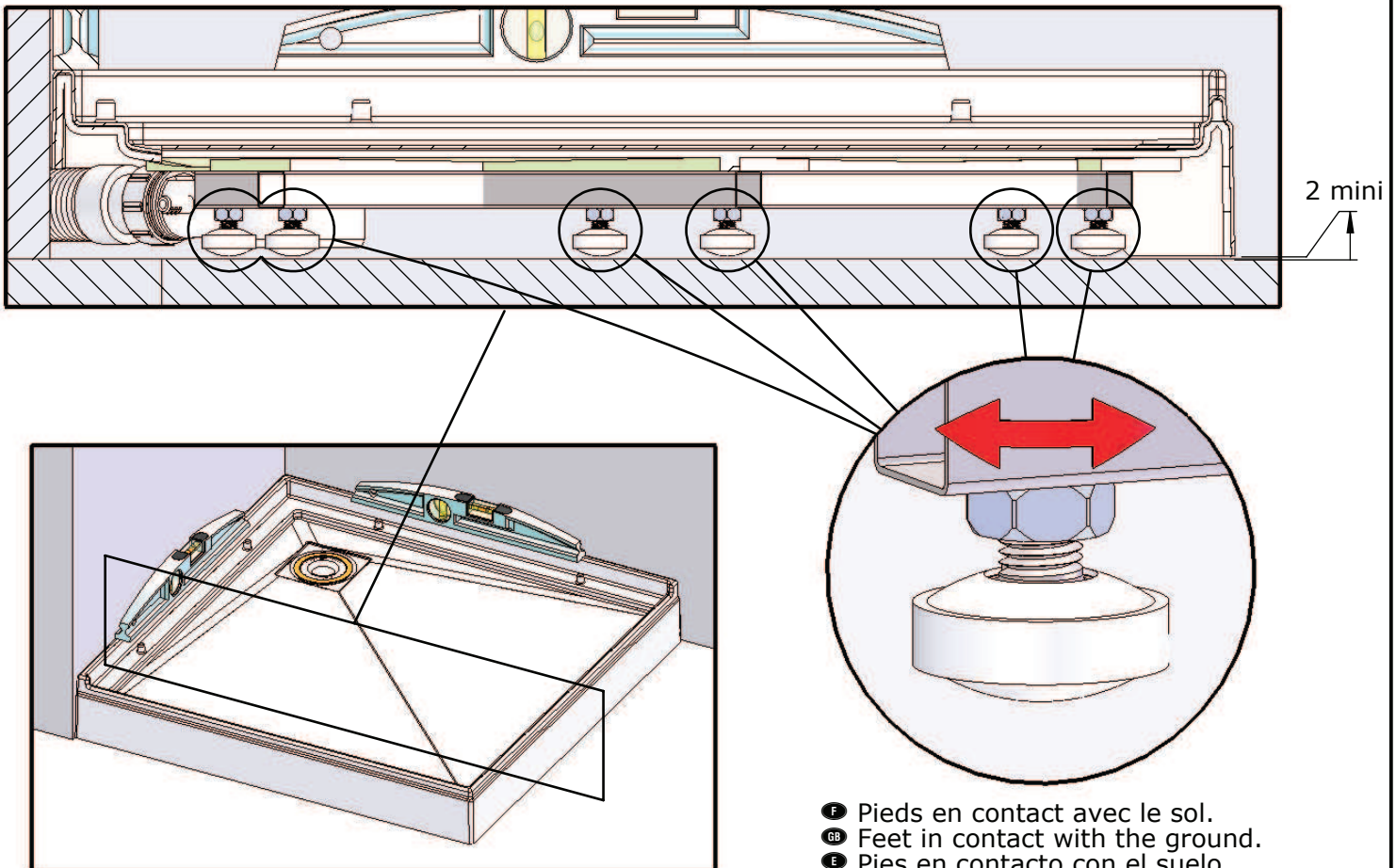

- F Pieds en contact avec le sol.
- GB Feet in contact with the ground.
- E Pies en contacto con el suelo.
- I Piedi a contatto con il terreno.
- NL Voeten in contact met de grond.

03

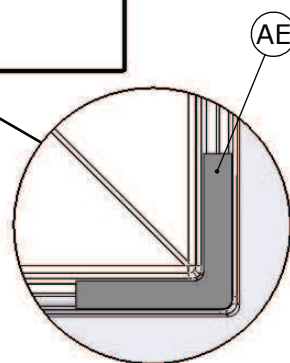
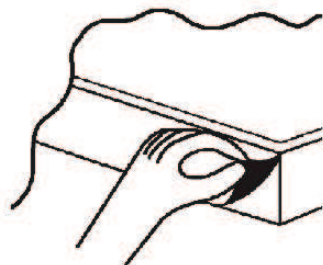
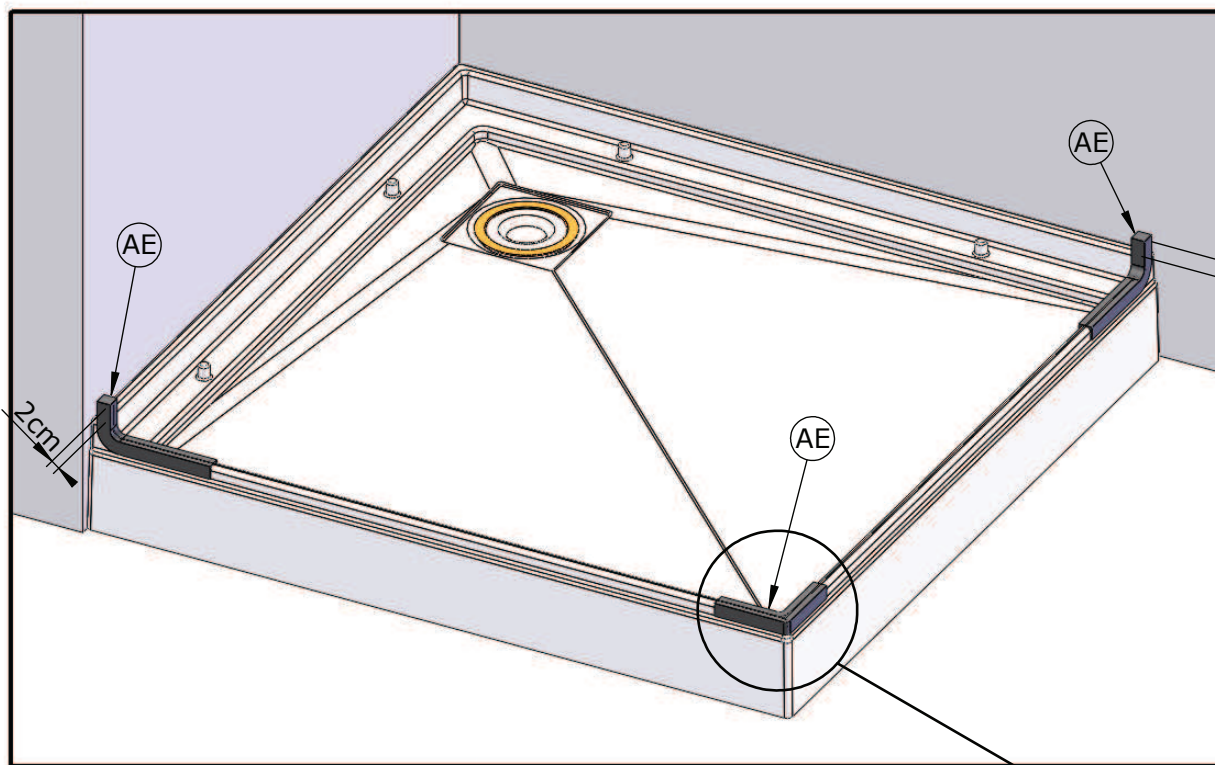

04

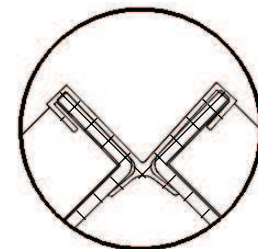
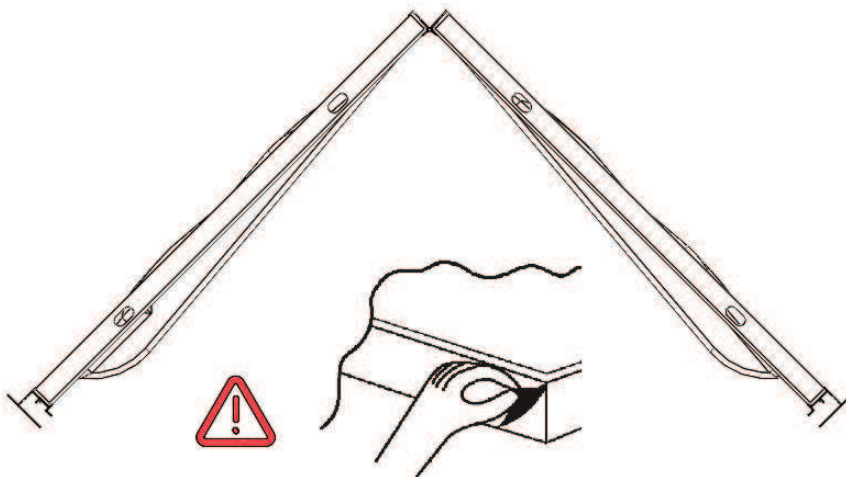
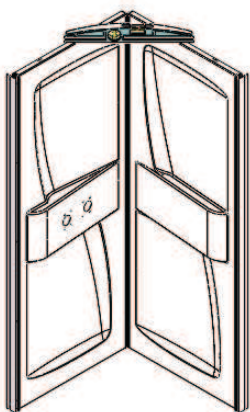
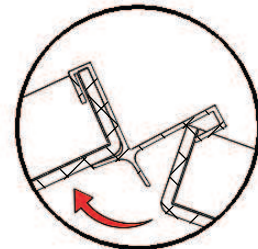
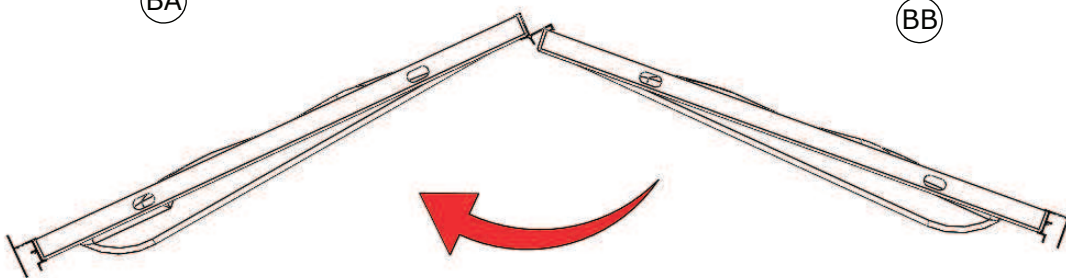
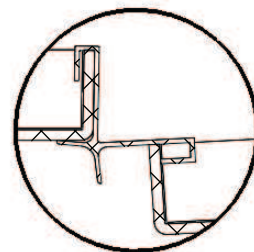
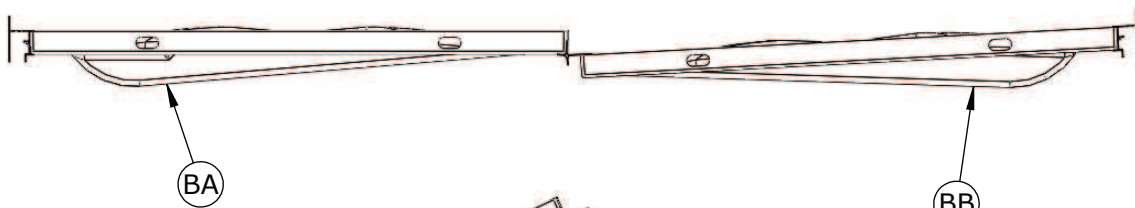

05

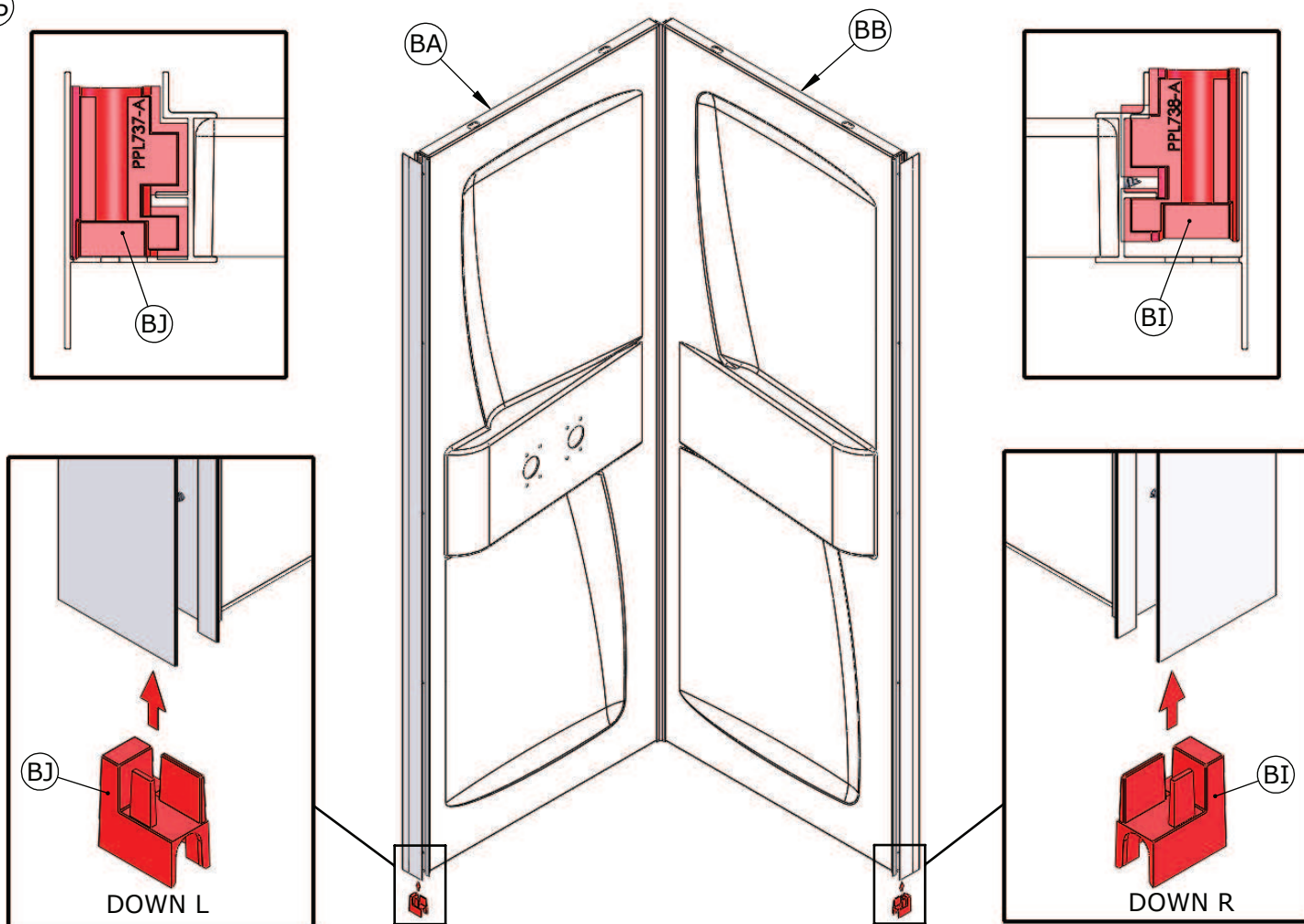

06

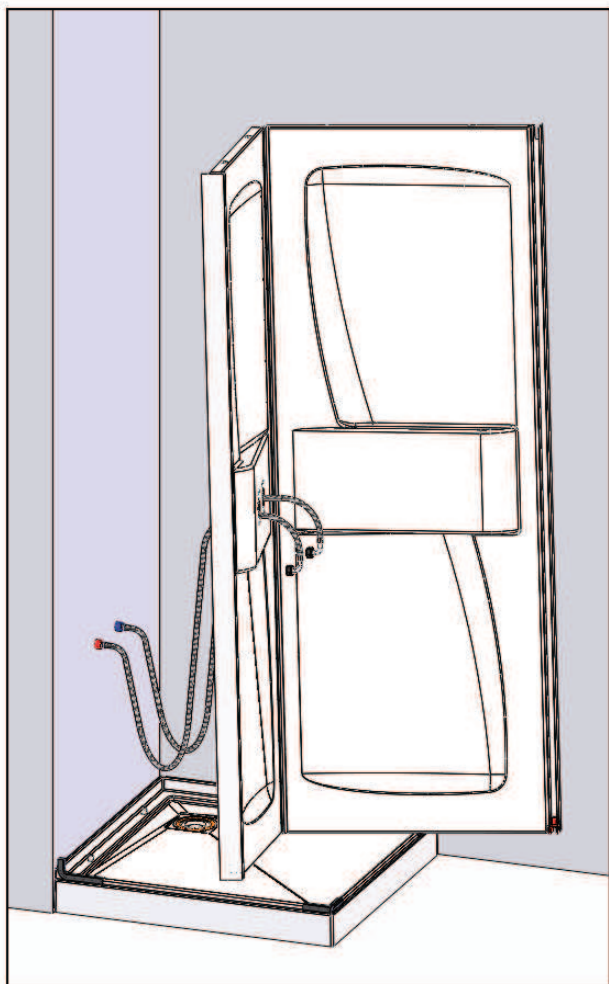

- F Raccorder l'arrivée d'eau avec vos flexibles d'alimentation.
- GB Connect the water supply with your supply hoses.
- E Conectar las acometidas de agua.
- I Raccordare l'alimentazione dell'acqua.
- NL Sluit de watertoevoer aan.

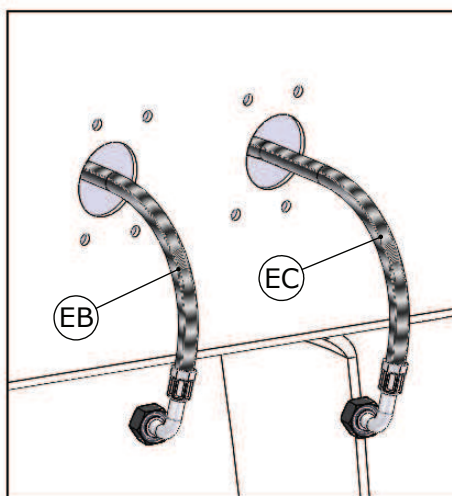

- F Passer vos flexibles d'alimentation dans les ouvertures prévues.
- GB Pass your supply hoses in the planned openings.
- E Pase los flexibles de alimentación en las aperturas previstas.
- I Passate i tubi flessibili di alimentazione nelle aperture previste.
- NL Geven de flexibele leidingen van voedsel in de voorziene openingen.

- F Raccorder l'arrivée d'eau et la liaison équipotentielle.
- GB Connecting the water inlet and the equipotential link.
- I Collegare l'ingresso dell'acqua e il collegamento equipotenziale.
- E Conexión de la entrada de agua y la conexión equipotencial.
- NL Het aansluiten van dewatertoevoer en de equipotentiaalverbinding.

07

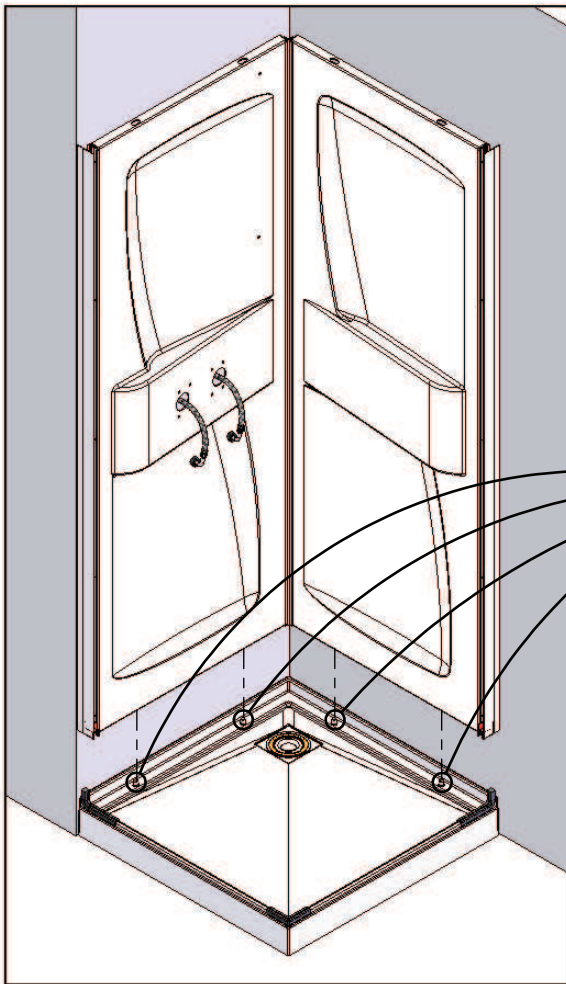

08

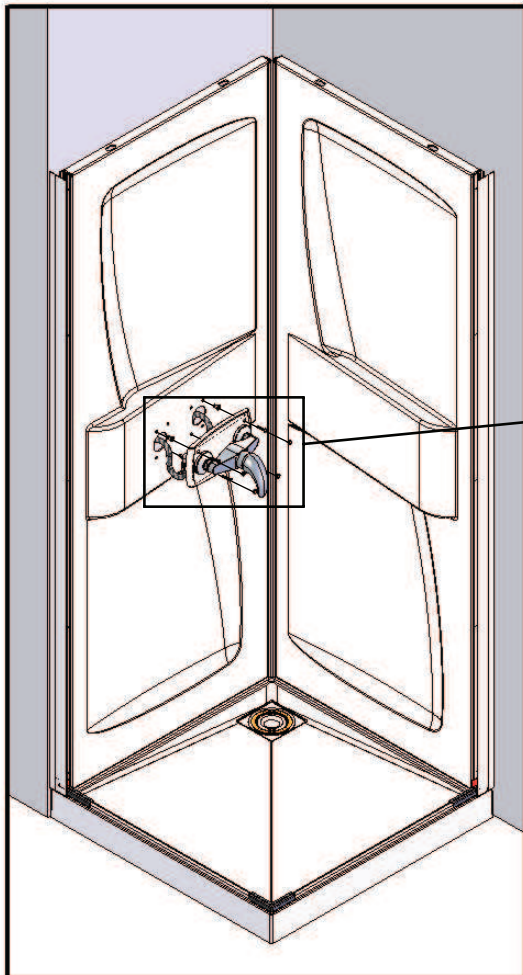

- F Raccorder vos flexibles d'alimentation avec votre mitigeur.
- GB Connect your supply hoses with your mixer.
- E Conectar los latiguillos al grifo.
- I Raccordare i flessibili di alimentazione al miscelatore.
- NL Sluit de watertoevoerslangen aan de kraan aan.

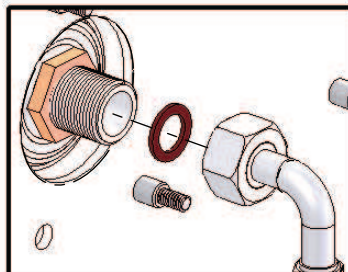
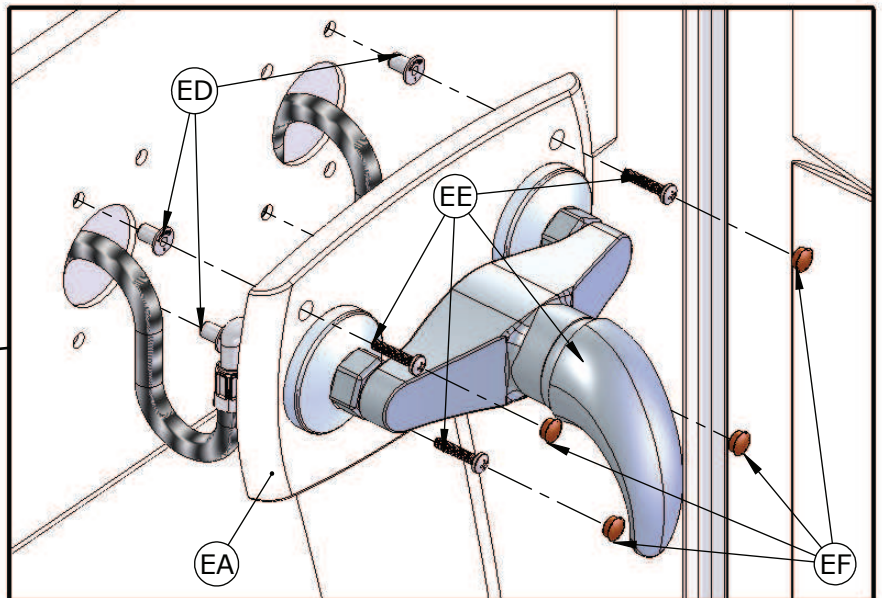

- F En fonction de votre version, possibilité mitigeur thermostatique ou pas de mitigeur.
- GB Depending on your version, possibility thermostatic mixer or no mixer
- E Según la versión, posibilidad mezclador termostático o no mezclador.
- I Seconda della versione, possibilità miscelatore termostatico o non miscelatore.
- NL Afhankelijk van de versie, mogelijkheid thermostatische kraan of niet kraan.

09

FR - En raison du transport et des diverses manipulations du produit, nous vous conseillons vivement de vérifier le bon serrage de chaque connexion, afin d'éviter tout problème de fuite lors de la mise en eau.

EN - Due to transportation and various product handling issues, we strongly recommend that you check that each connection is properly tightened in order to avoid any potential leakage problems when put under pressure.

ES - Debido al transporte y a las distintas manipulaciones del producto, le aconsejamos comprobar que sujeción de cada conexión sea correcta, para evitar los problemas de fuga una vez se conecte con el agua.

IT - A causa del trasporto e delle diverse manipolazioni del prodotto, vi consigliamo vivamente di controllare il buon serraggio di tutti i collegamenti allo scopo di evitare perdite d'acqua.

NL - Door het transport en de diverse logistieke handelingen met het product dient u elke slangconnectie (koppeling/aansluiting) extra te controleren op waterdichtheid alvorens u de douchecabine definitief plaatst. Hiermee vermijdt u mogelijke lekkages nadat het water op druk wordt aangesloten.

10

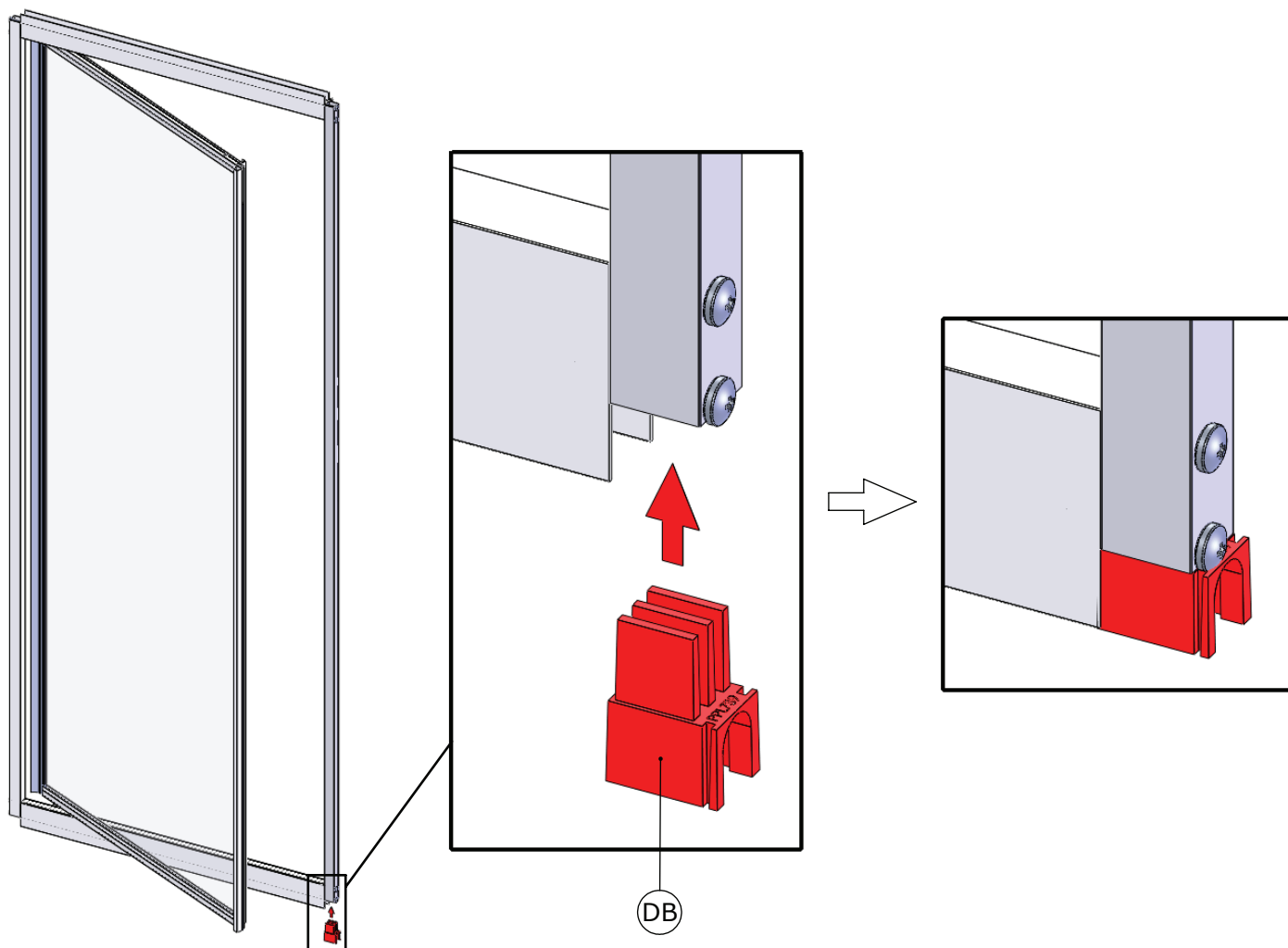

11

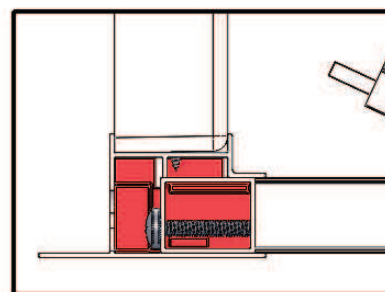
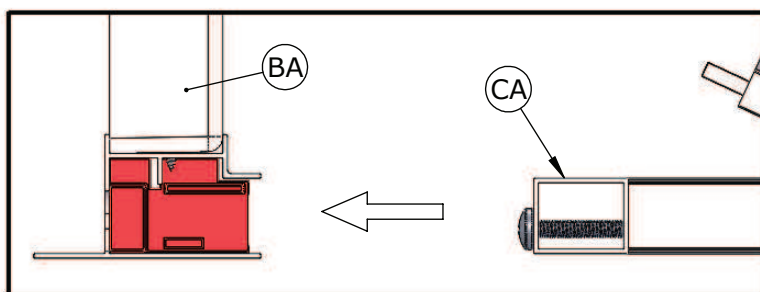
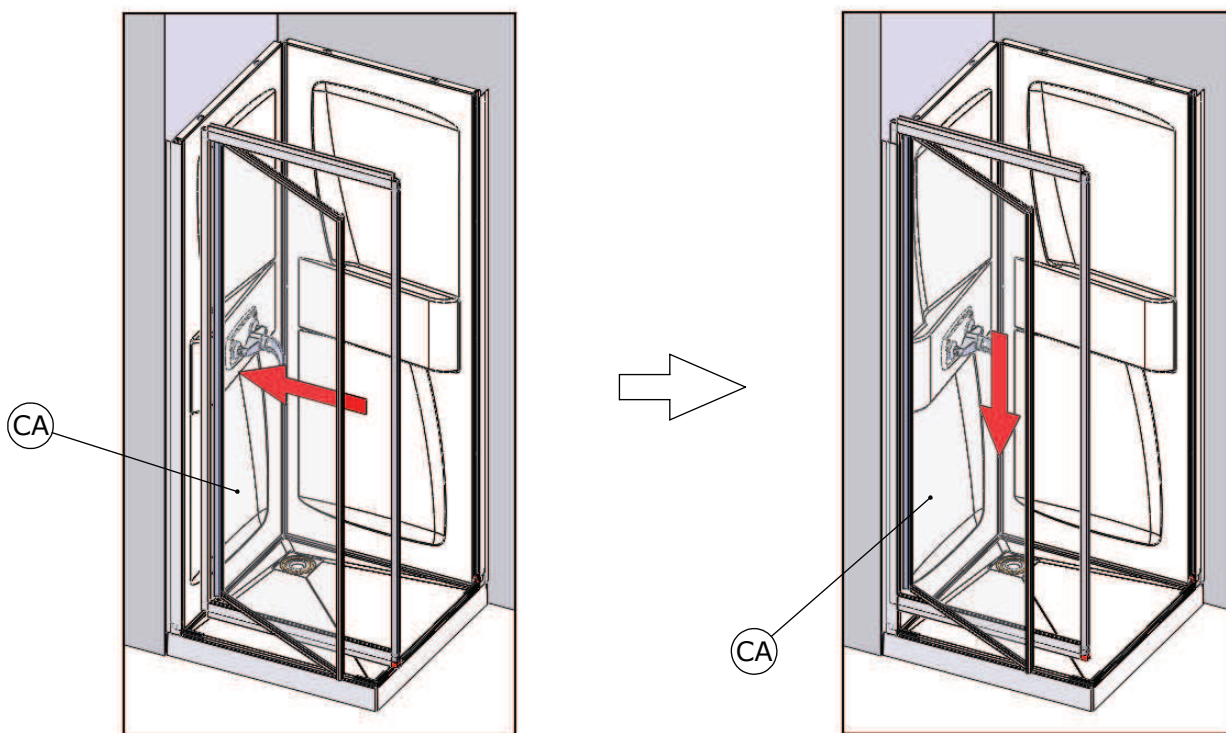

12

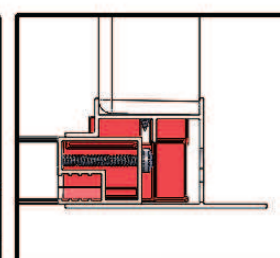
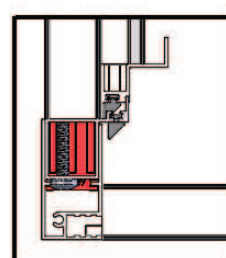
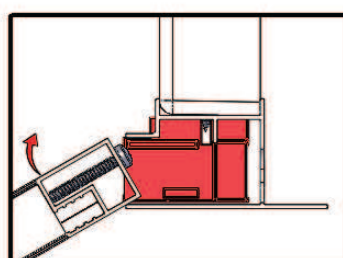
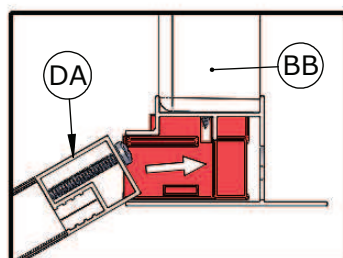
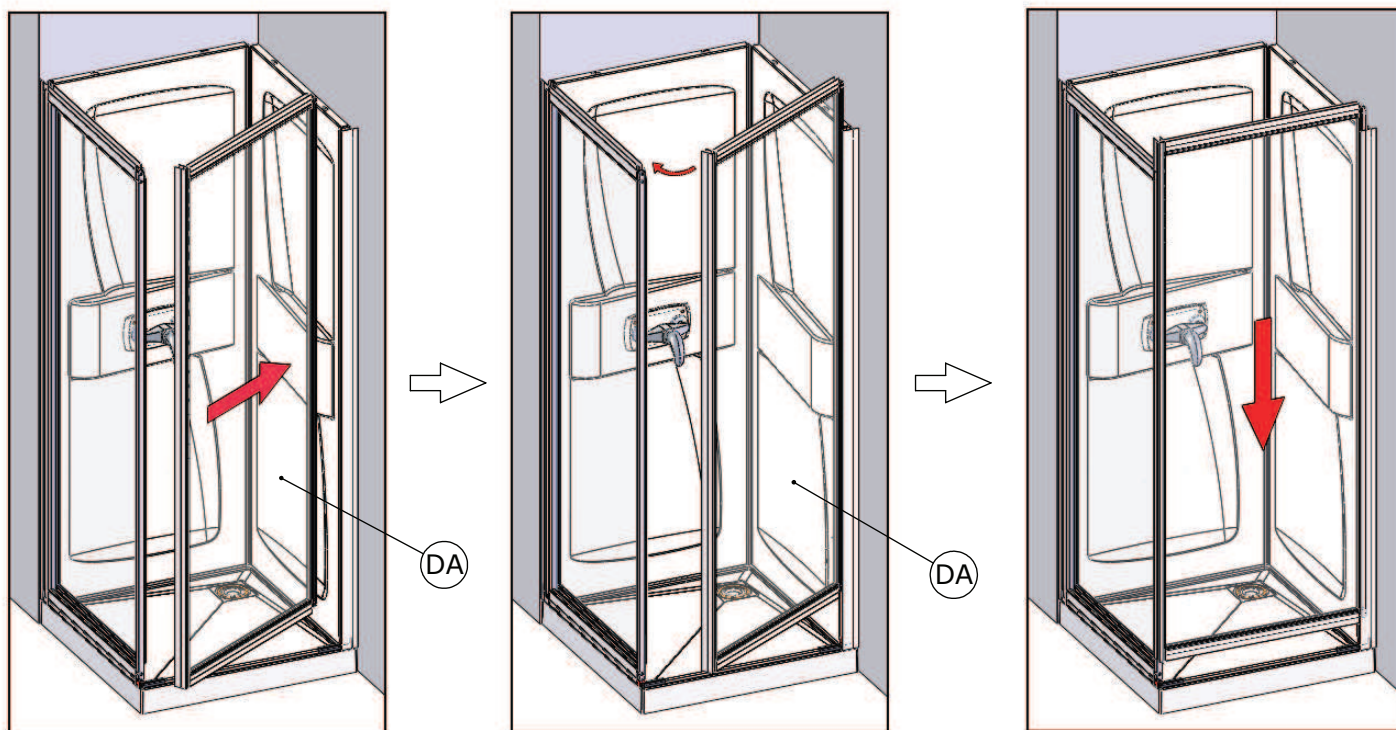

13

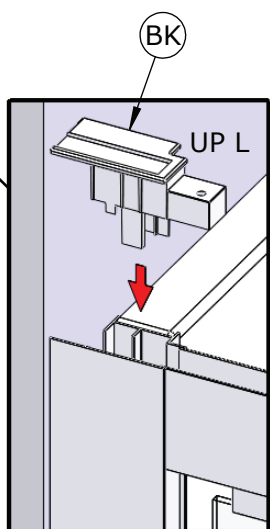
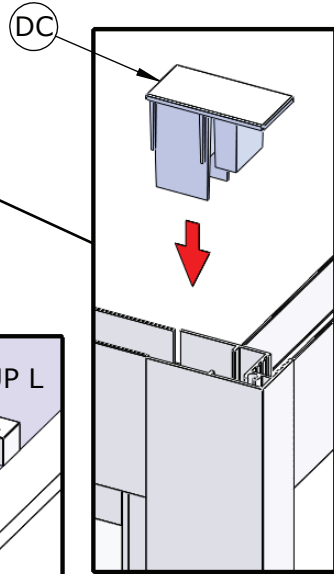
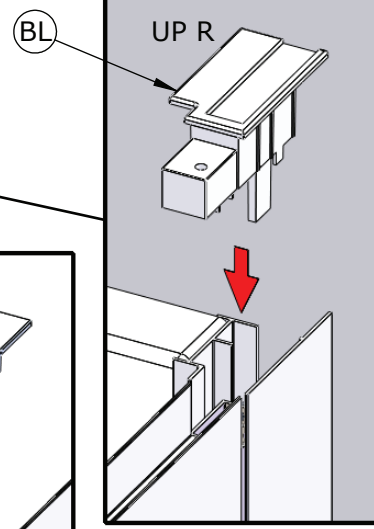
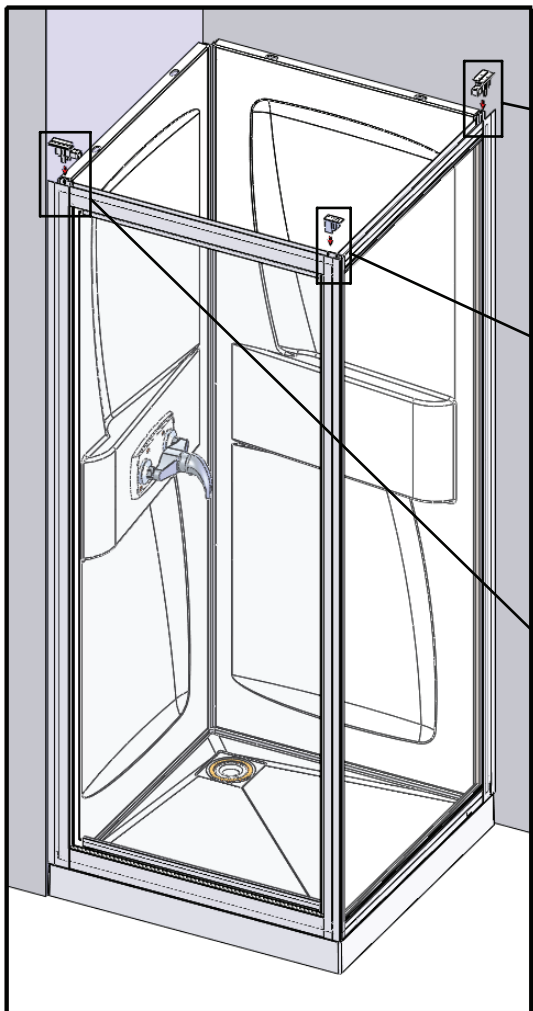

14

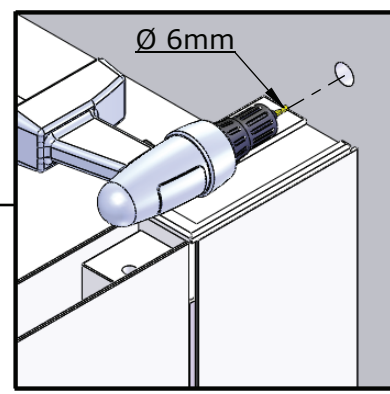
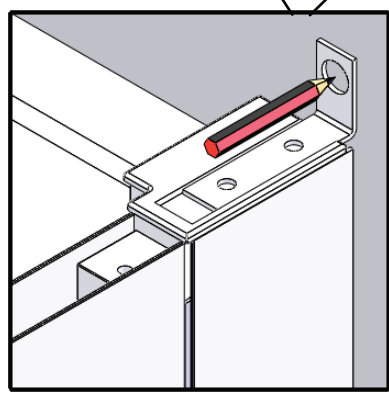
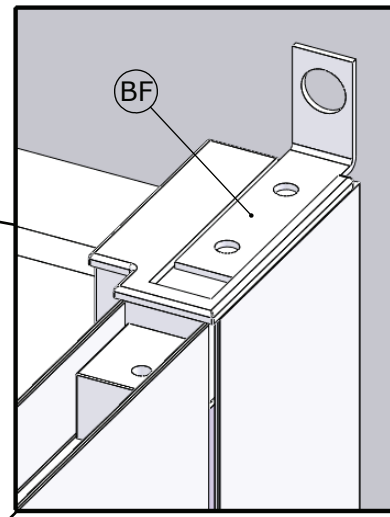
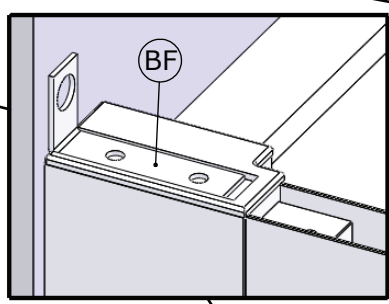
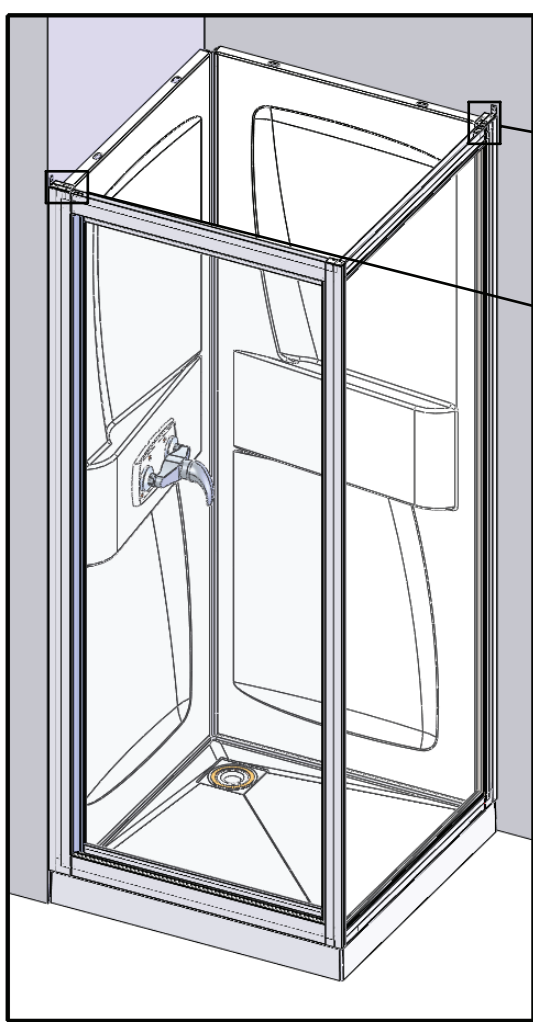

15

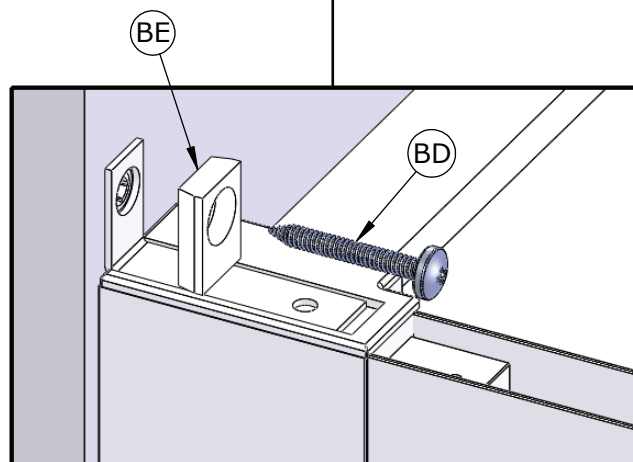
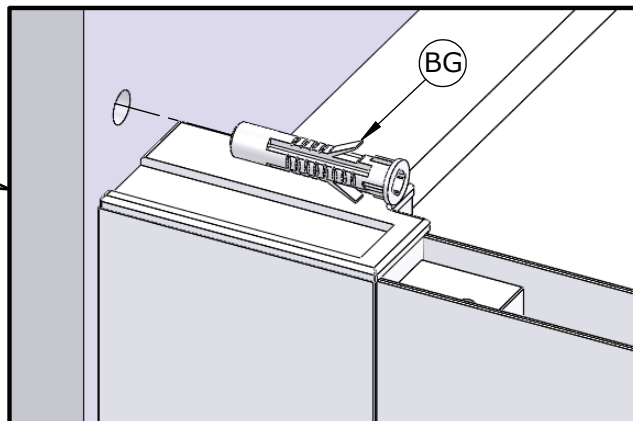
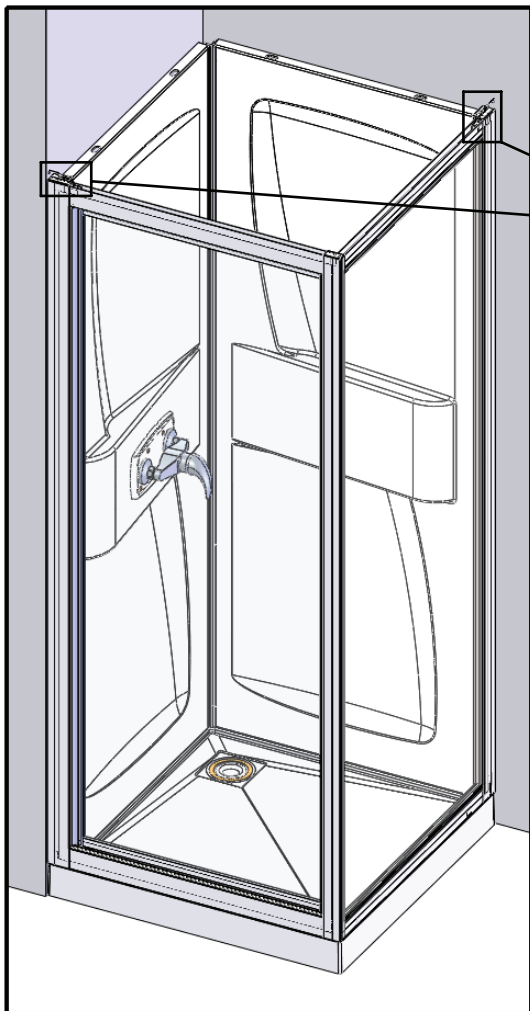

16

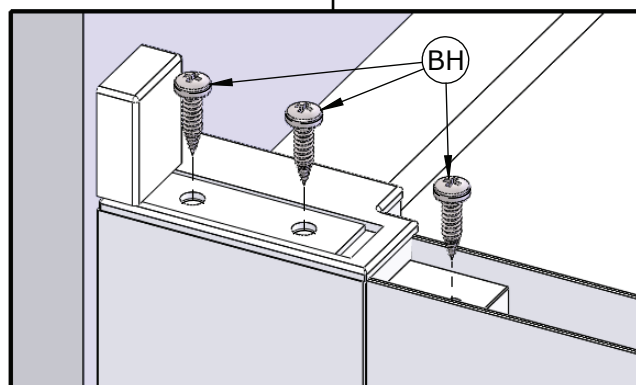
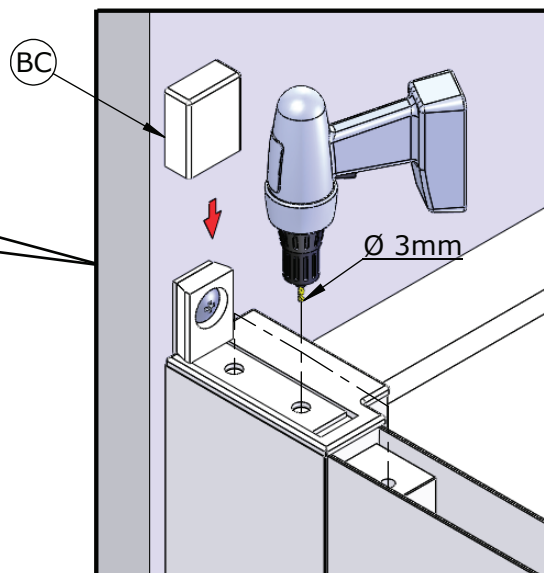
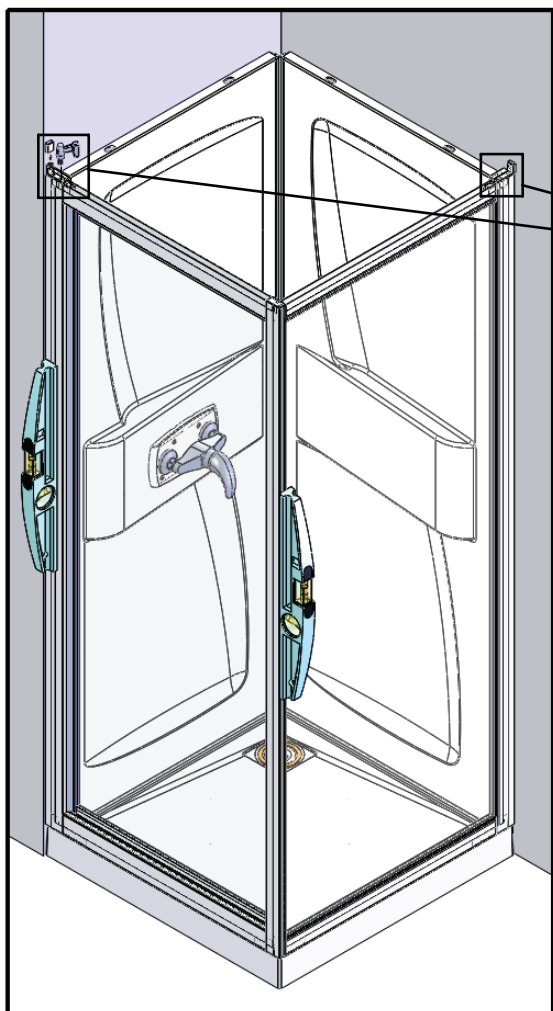

17

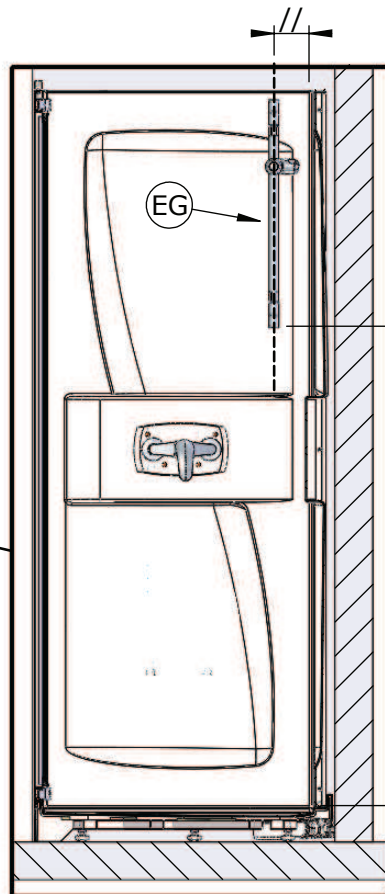
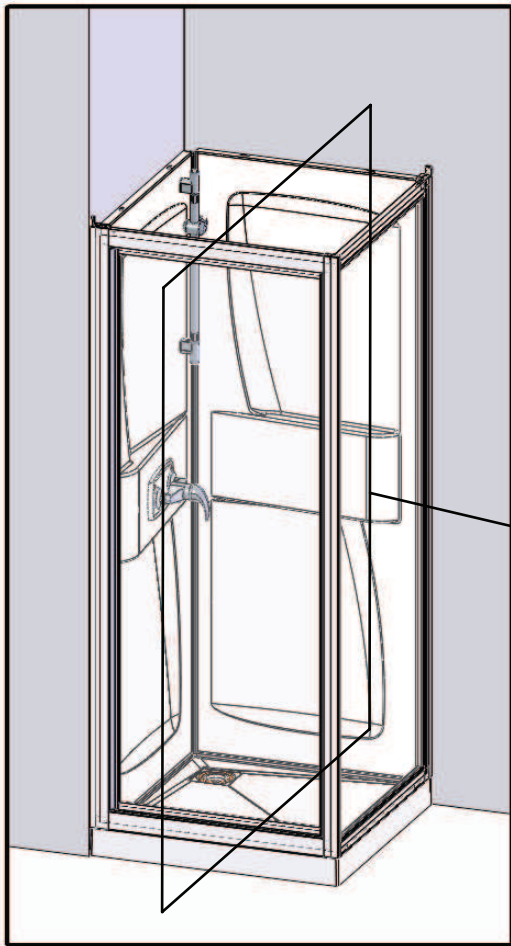

- F Vous avez le choix de la position de la barre de douche.
- GB You can choose the position of the shower bar.
- E Usted puede escoger la posición de la barra de ducha.
- I Potete scegliere la posizione della barra di doccia.
- NL U kunt de positie van de roer van douche.

18

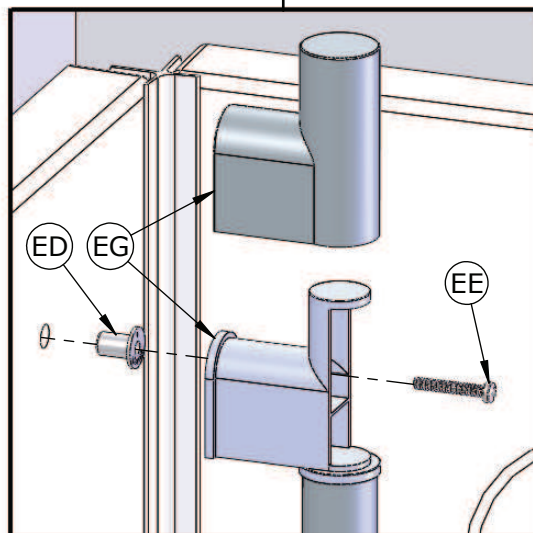
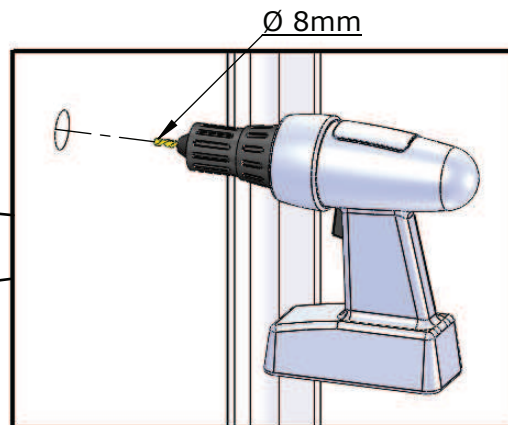
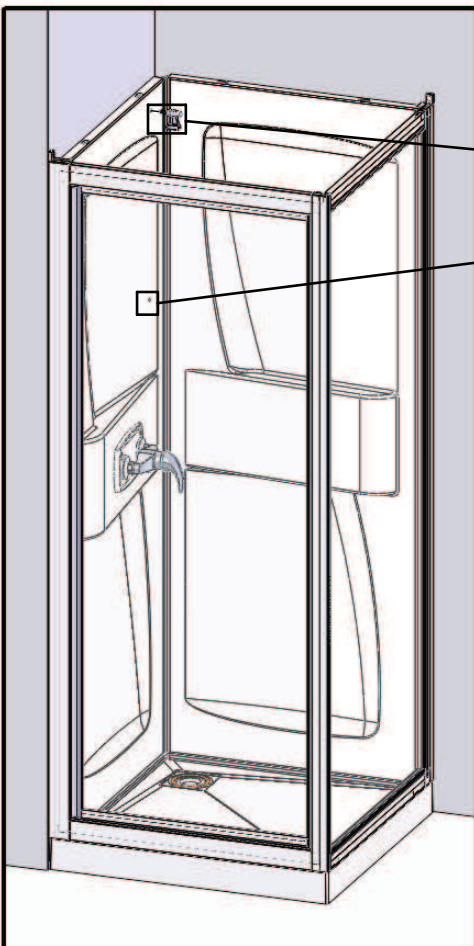

19

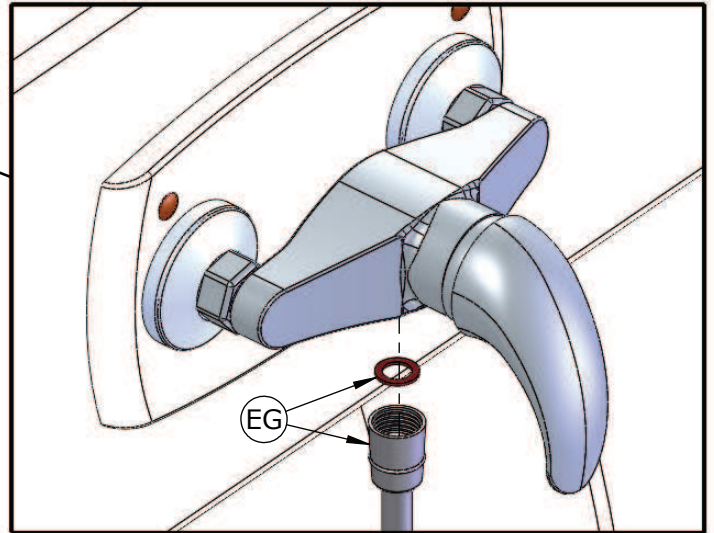
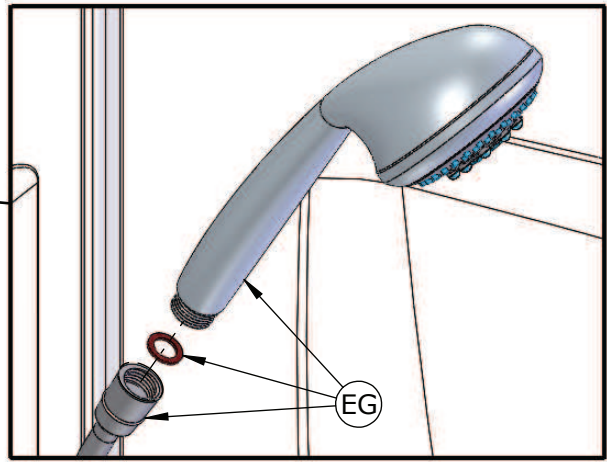
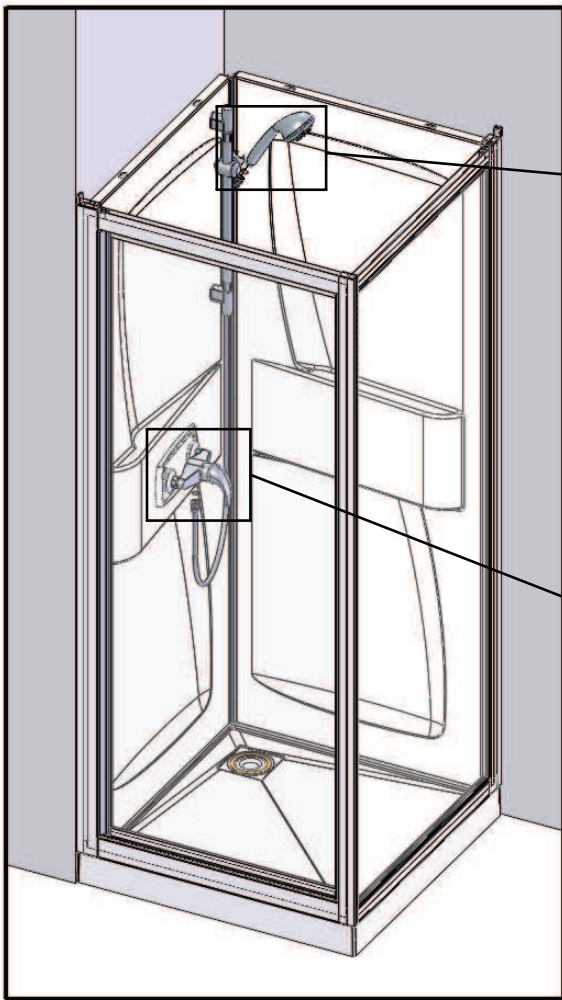

20

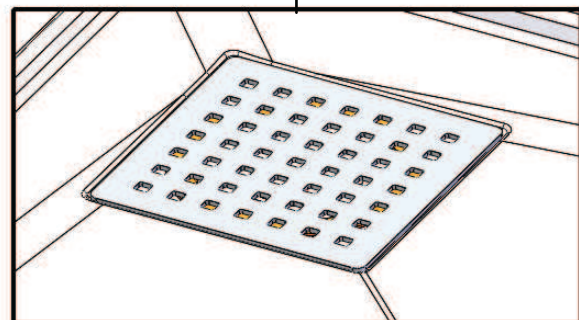
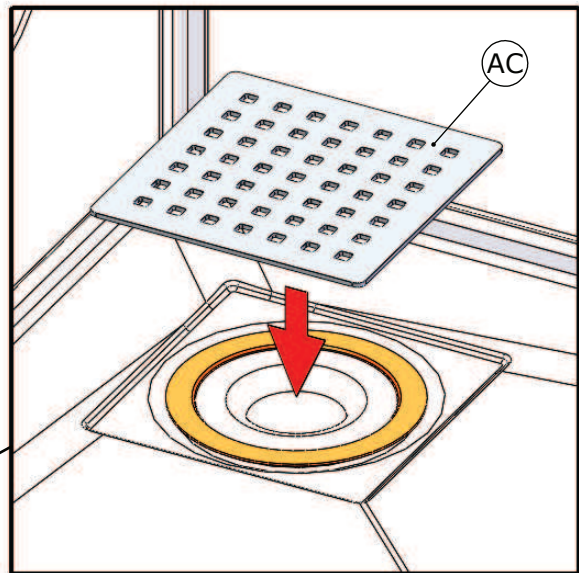
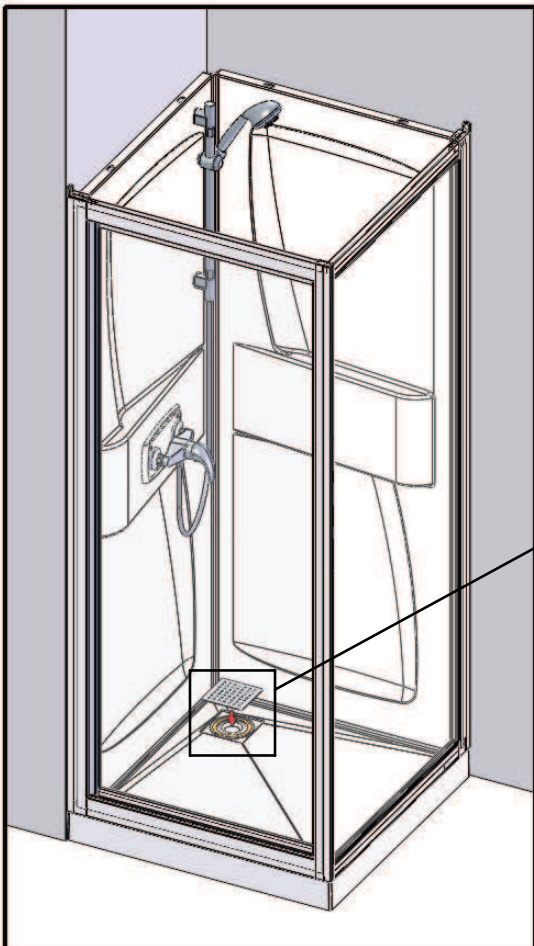

(21)

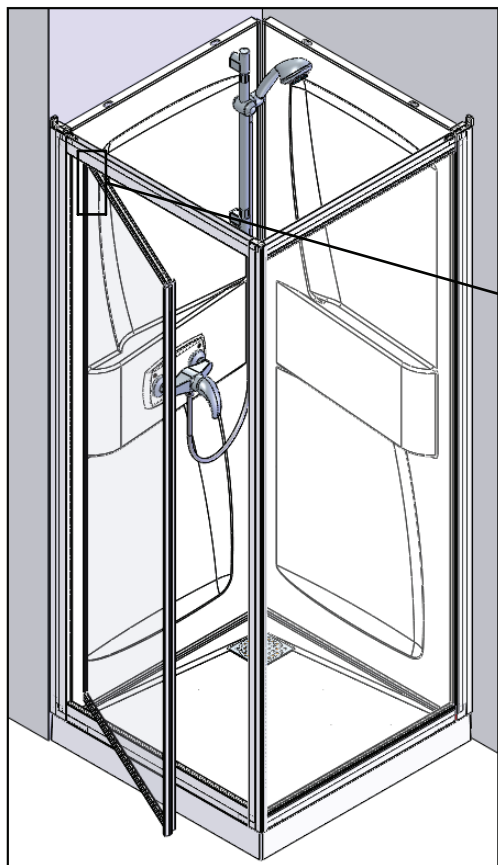

Côté extérieur
Outside
En el fuera
Esterna
Buitenzijde

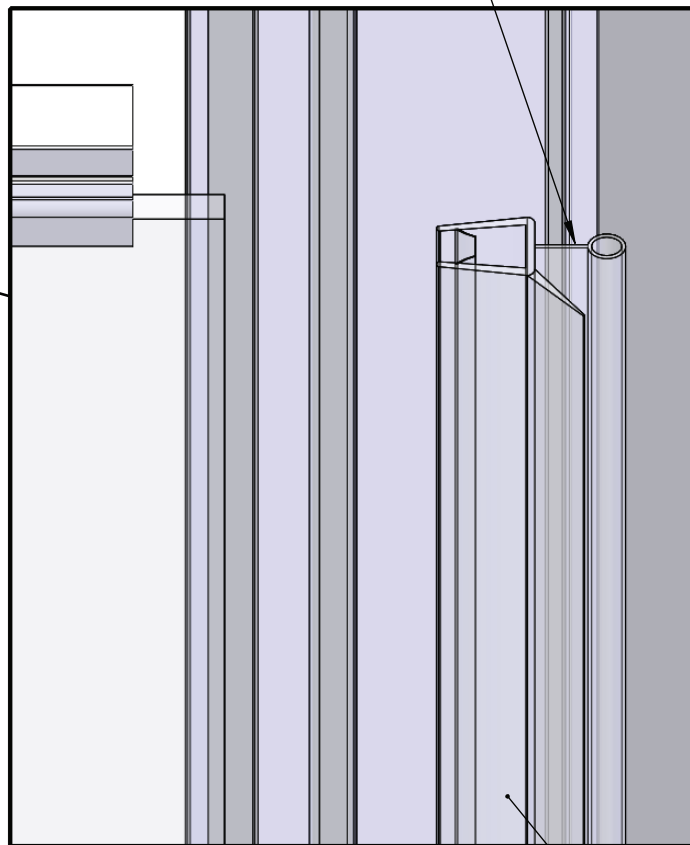

(CB)



-F-

POUR LA PROTECTION ELECTRIQUE DE VOTRE DOUCHE, IL EST NECESSAIRE DE RELIER LES ORGANES METALLIQUES DE VOTRE PRODUIT AU CIRCUIT EQUIPOTENTIEL DE VOTRE INSTALLATION.

VOUS POUVEZ CONTACTER VOTRE INSTALLATEUR HABITUEL, IL SAURA VOUS CONSEILLER.



-GB-

FOR THE ELECTRONIC PROTECTION OF YOUR SHOWER, THE METAL PARTS OF YOUR PRODUCT SHOULD BE CONNECTED TO THE EQUIPOTENTIAL CIRCUIT OF YOUR INSTALLATION.

CONTACT YOUR USUAL SHOWER FITTER FOR ADVICE.

-NL-

VOOR DE ELEKTRISCHE BESCHERMING VAN UW DOUCHE MOETEN DE METALEN DELEN VAN UW PRODUCT WORDEN AANGESLOTEN OP HET EQUIPOTENTIALE CIRCUIT VAN UW INSTALLATIE.

NEEM HIERVOOR CONTACT OP MET UW NORMALE INSTALLATEUR, HIJ KAN U ADVISEREN.

-I-

PER GARANTIRE LA PROTEZIONE ELETTRICA DELLA DOCCIA OCCORRE COLLEGARE LE PARTI METALLICHE AL CIRCUITO EQUIPOTENZIALE DELL'APPARECCHIO.

CHIEDERE CONSIGLIO ALL'ELETTICISTA DI FIDUCIA

-ES-

PARA LA PROTECCIÓN ELÉCTRICA DE SU DUCHA, SERÁ NECESARIO CONECTAR LOS ELEMENTOS METÁLICOS DE SU PRODUCTO AL CIRCUITO EQUIPOTENCIAL DE SU INSTALACIÓN.

PÓNGASE EN CONTACTO CON SU INSTALADOR HABITUAL, ÉSTE SABRÁ ACONSEJARLE.



SAV
SERVICE HELPLINES
ASSISTENZA POST-VENDITA
SERVICIO POSTVENTA

FRANCE

N°Azur 0 810 05 1998
prix d'un appel local

UK

020 8842 0033

IRELAND

04697 33102

DEUTSCHLAND

0800 82 27 82 0

ITALIA

(0382) 6181

OSTEREICH

(0222) 21 402 16 0

SCHWEIZ

(01) 748 17 44

ESPANA

93 544 60 76

NEDERLAND

0475 487 100

BELGIË

+31 475 487 100

BELGIQUE

+31 475 487 100

РОССИЯ

963 19 40, 773 67 22