

GB Installation instructions

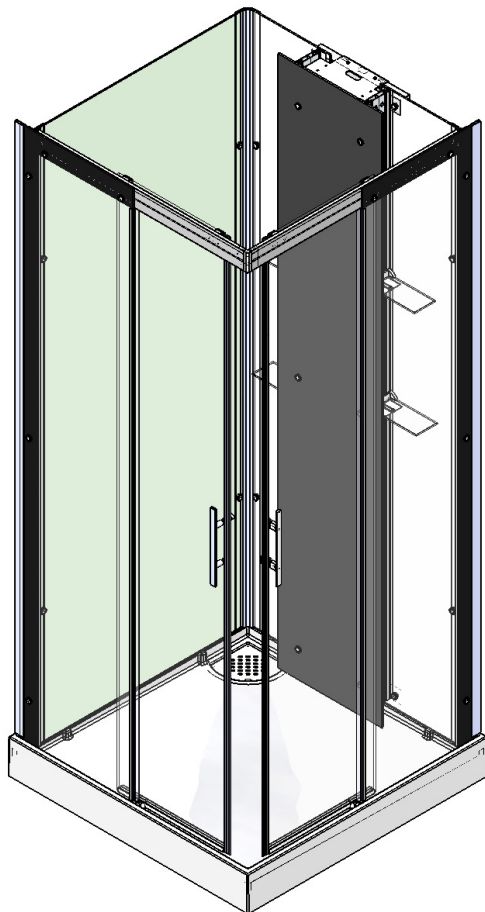

GB Check installation steps :

p.8 - p.12 - p.36

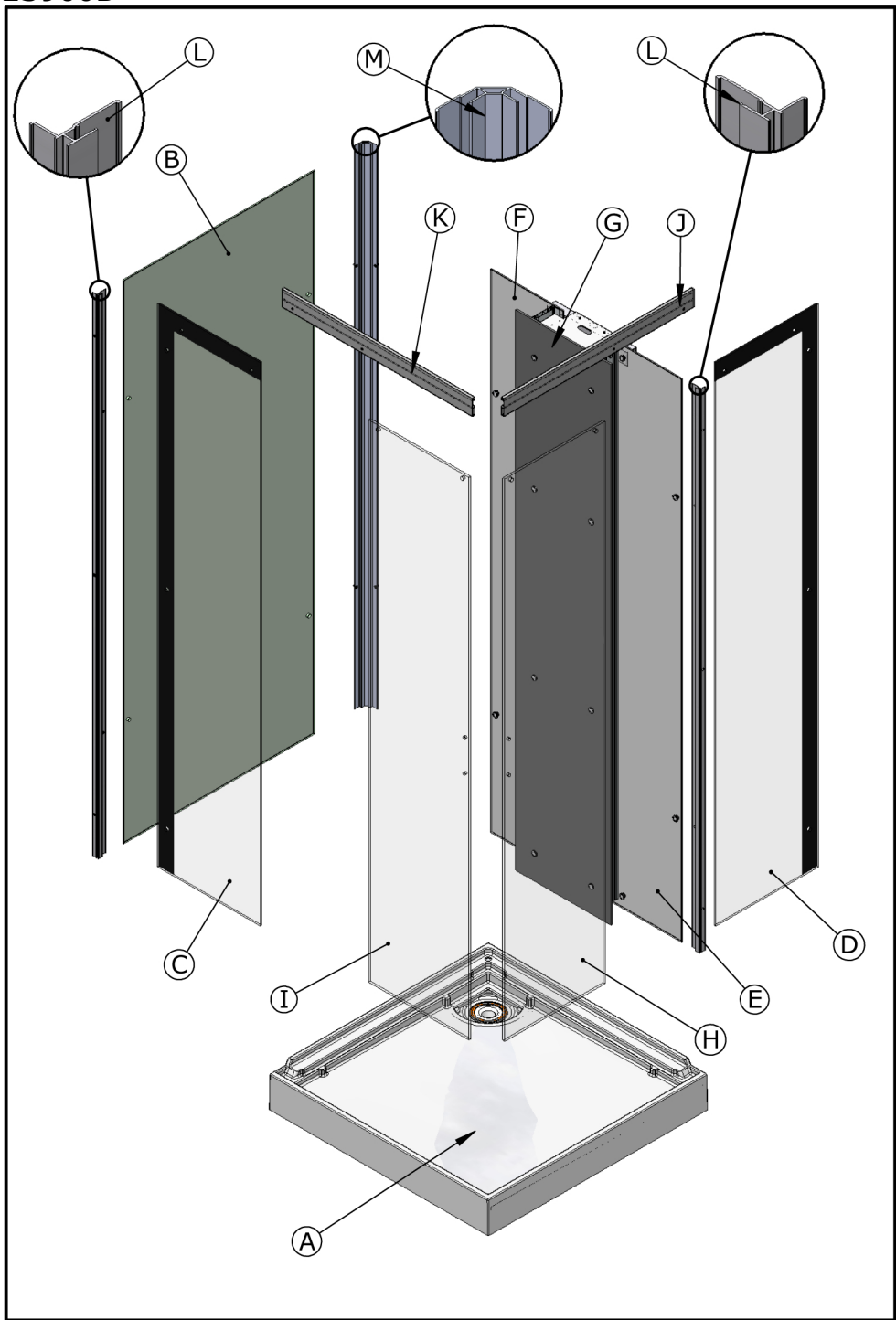



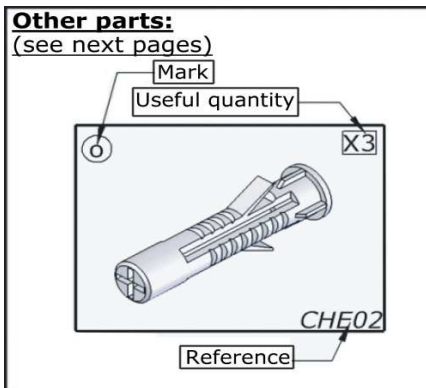

PACKAGE CODES (see marks on page 2)



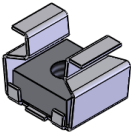
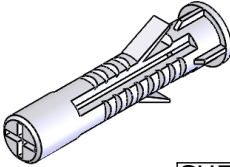
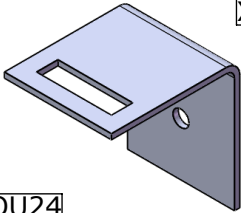
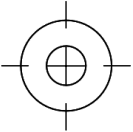
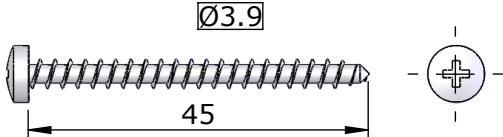
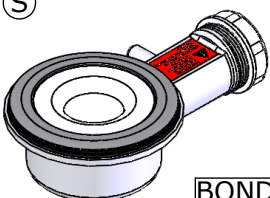
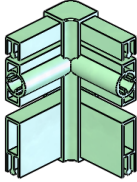
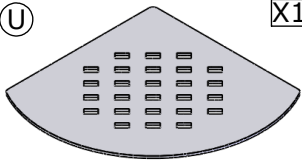
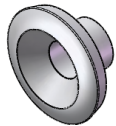

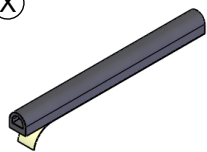
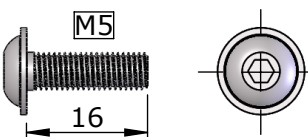
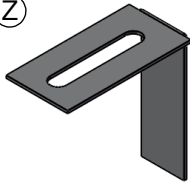
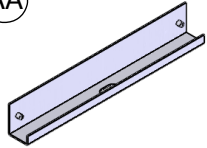
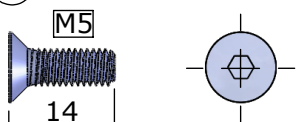
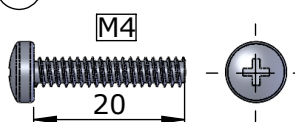
REP	80x80	90x90
A	REC204	REC203
B	C5077E	C5072E
C+D	C7741E	C6049E
E+F	C7202E	C7215E
G	CP850	
H+I	C4843E	C4841E
J+K	5902	
L	5934	
M	5933	

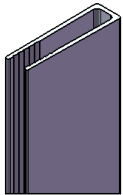
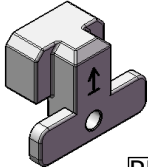

DES900B

<p>(N) X3</p>  <p>ECR46</p>	<p>(O) X3</p>  <p>CHE02</p>	<p>(P) X3</p>  <p>EQU24</p>
<p>(Q) X5</p>  <p>1=1 RON51</p>	<p>(R) X3</p>  <p>Ø3.9 45</p> <p>1=1 VIS17</p>	
<p>(S) X1</p>  <p>BOND16</p>	<p>(T) X1</p>  <p>PPL353</p>	<p>(U) X1</p>  <p>TOL12</p>
<p>(V) X22</p>  <p>ENT19</p>	<p>(W) X18</p>  <p>M5 20</p> <p>1=1 VIS10</p>	<p>(X) X2</p>  <p>J446</p>
<p>(Y) X3</p>  <p>M5 16</p> <p>1=1 VIS195</p>	<p>(Z) X3</p>  <p>EQU50</p>	<p>(AA) X2</p>  <p>SUP63</p>
<p>(AB) X4</p>  <p>M5 14</p> <p>1=1 VIS159</p>	<p>(AC) X4</p>  <p>M4 20</p> <p>1=1 VIS09</p>	<p>(AD) X4</p>  <p>ECR14</p>

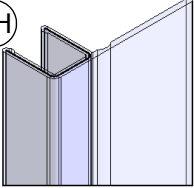
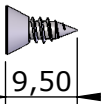
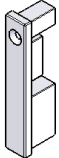
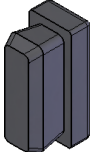
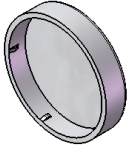
The quantities given are what are required for the installation. There may be some surplus parts in the package provided.

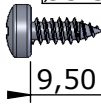
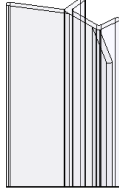
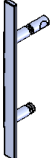
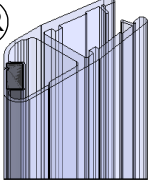
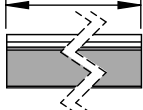
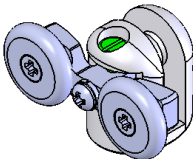
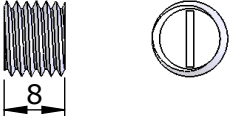
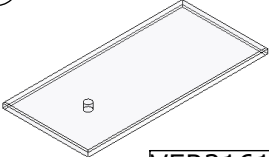
<p>(AE)  X2</p> <p>PFL42</p>	<p>(AF)  X1</p> <p>PPL550</p>	<p>(AG)  X1</p> <p>PPL523</p> <p>PPL522</p>
<p>(AH)  X2</p> <p>LG=1925mm J418</p>	<p>(AI)  X2</p> <p>$\varnothing 3.5$ 9,50 1=1</p> <p>VIS22</p>	<p>(AJ)  X2</p> <p>PPL520</p>
<p>(AK)  X2</p> <p>BUT22</p>	<p>(AL)  X22</p> <p>CAP07</p>	<p>(AM)  X4</p> <p>ECR31</p>
<p>(AN)  X2</p> <p>BUT20</p>	<p>(AO)  X4</p> <p>$\varnothing 3.5$ 9,50 1=1</p> <p>VIS01</p>	<p>(AP)  X2</p> <p>LG=1970mm J540</p>
<p>(AQ)  X2</p> <p>S0948</p>	<p>(AR)  X1</p> <p>LG=1995mm</p> <p>AI038 AI039</p>	<p>(AS)  X2</p> <p>80x80=345mm 90x90=393mm</p> <p>80x80=J440 90x90=J439</p>
<p>(AT)  X4</p> <p>ROU21</p>	<p>(AU)  X2</p> <p>M10 8 1=1</p> <p>VIS07</p>	<p>(AV)  X4</p> <p>VER2161</p>

DES900B

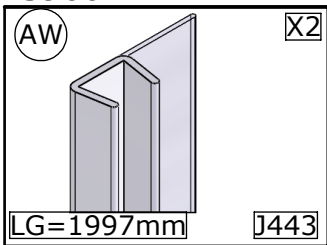

REQUIRED TOOLS

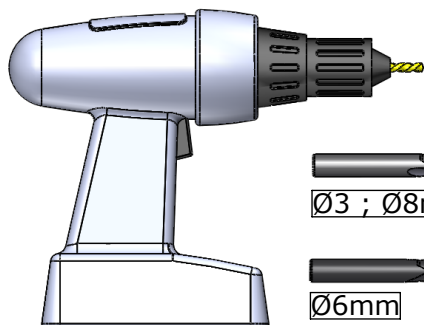
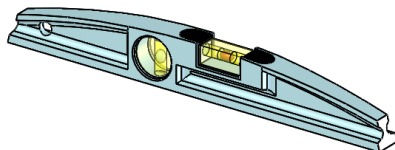
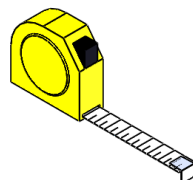
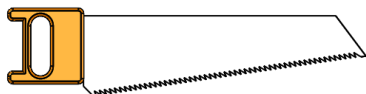
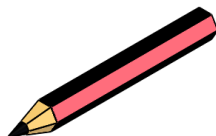

Ø3 ; Ø8mm



Ø6mm

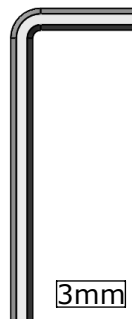

3mm



X2

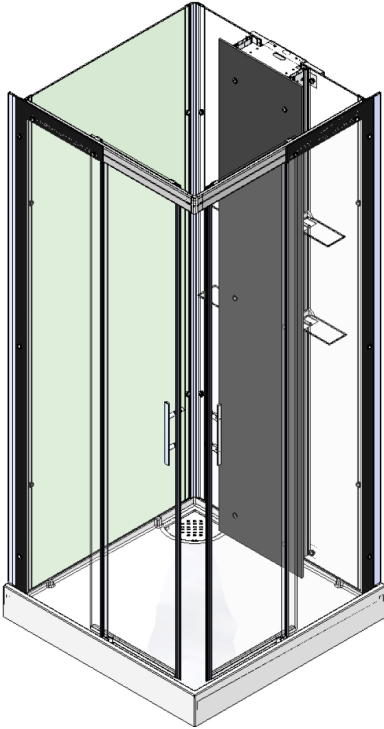
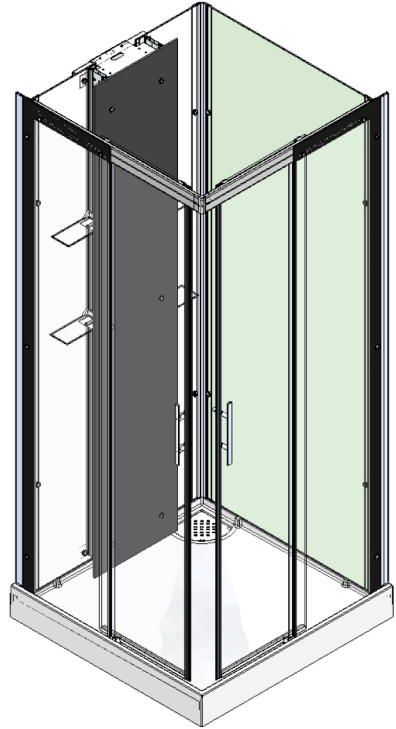

The quantities given are what are required for the installation. There may be some surplus parts in the package provided.

REVERSIBILITY**LEFT HAND****RIGHT HAND**

This cubicle can be installed either left or right hand. These installation instructions show a right hand installation.

01

Ø6 mm

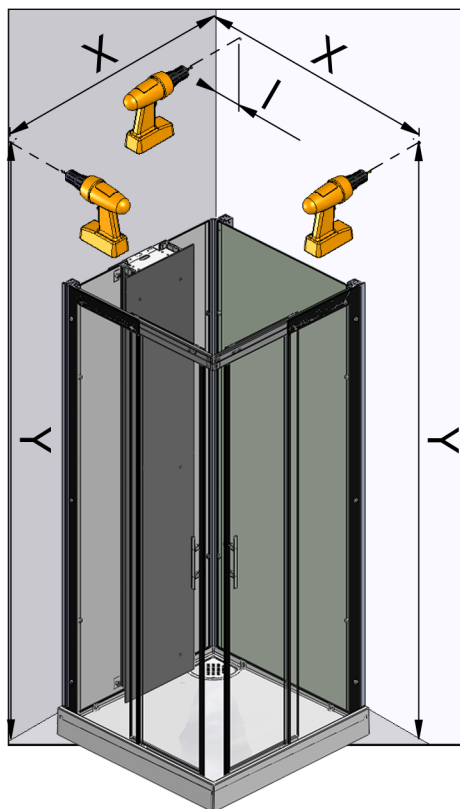
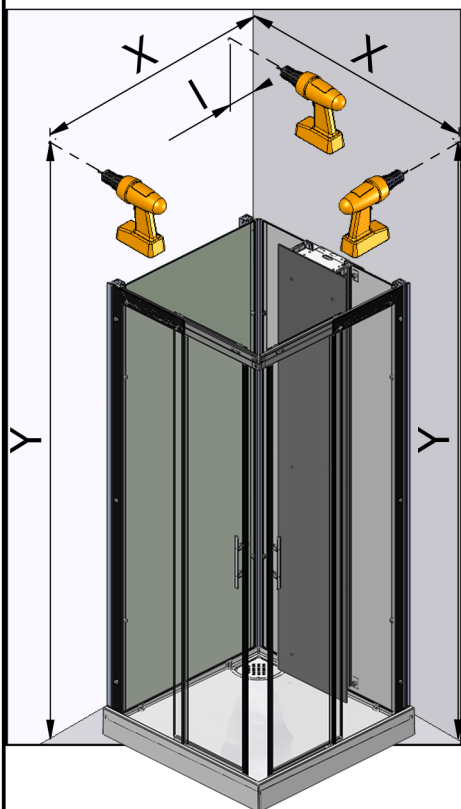

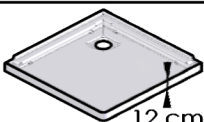
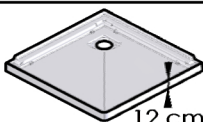
	80x80	90x90
X	74 cm	84 cm
Y	 206 cm	 207 cm
I	10 cm	

02

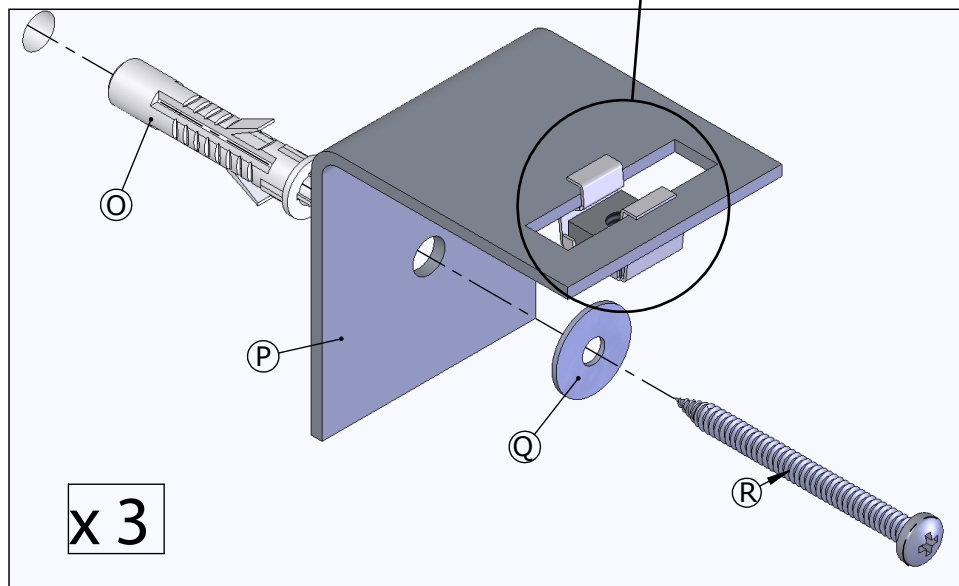
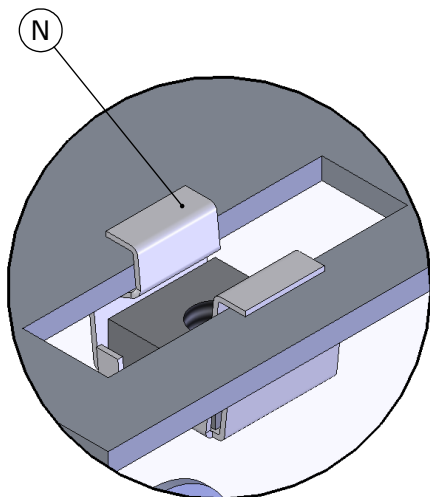

x 3

03

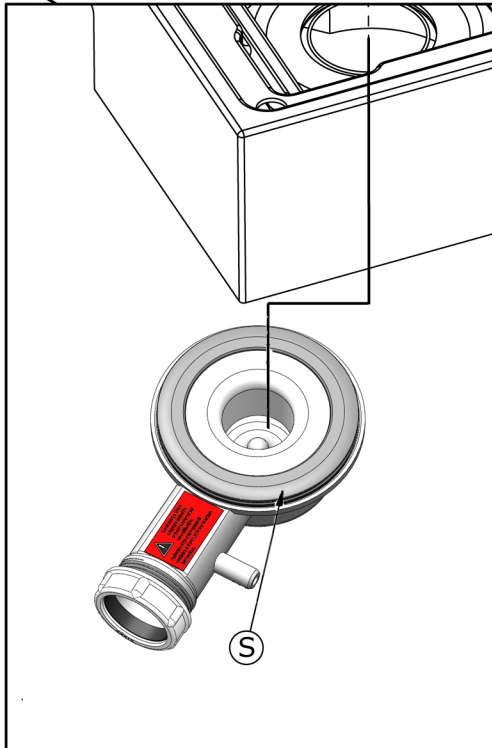
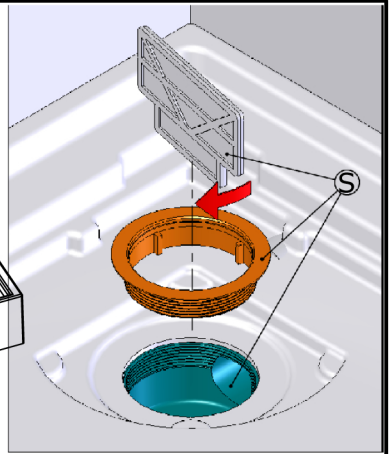
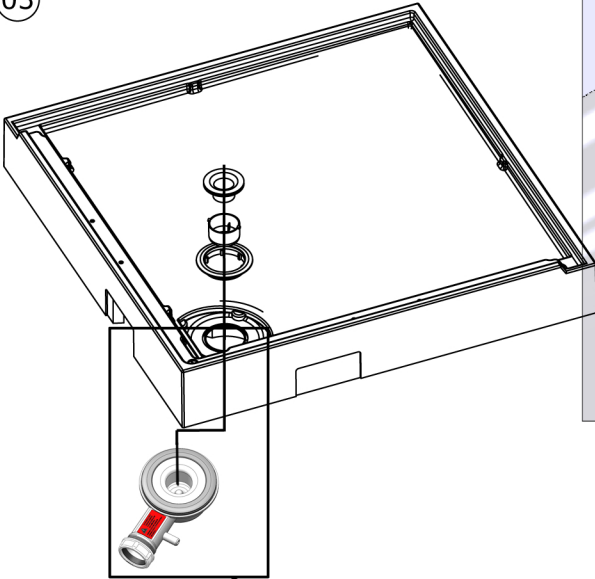

04

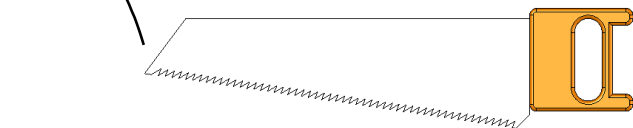
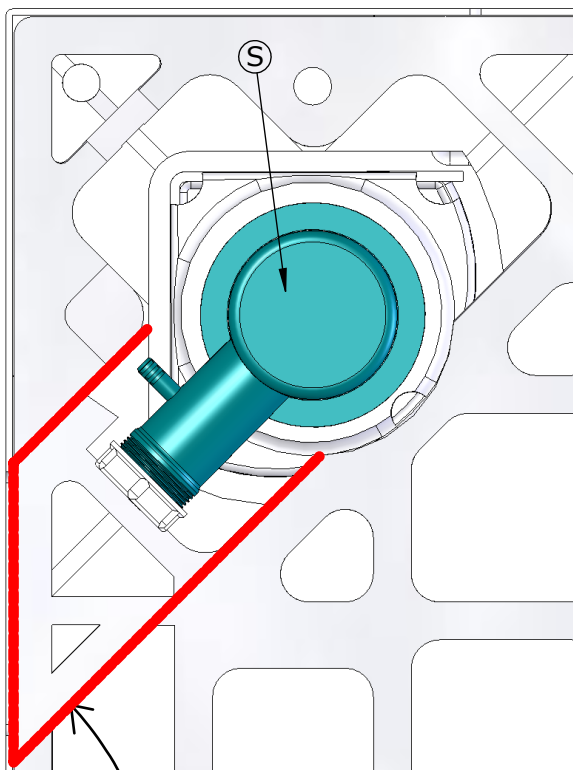

05

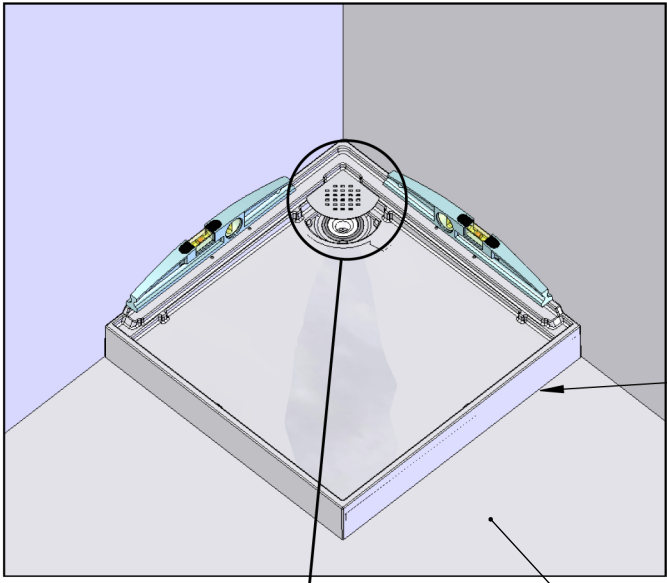

The underlying surface must be perfectly rigid

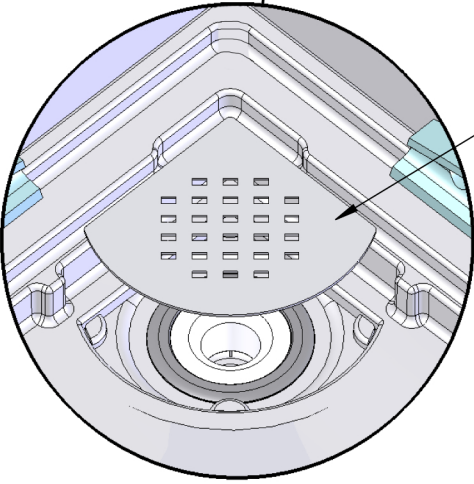

06 Screen printing on the outside

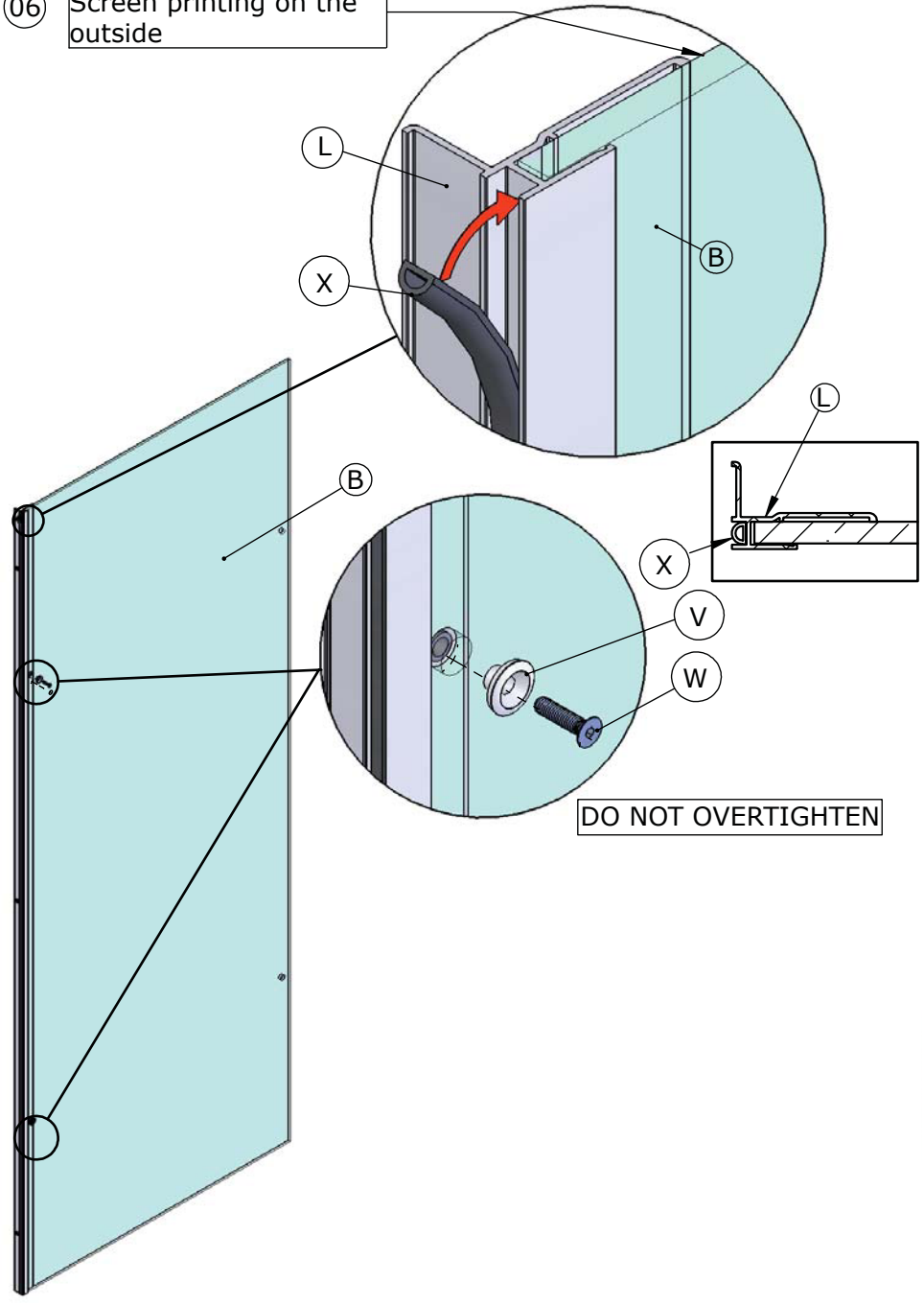

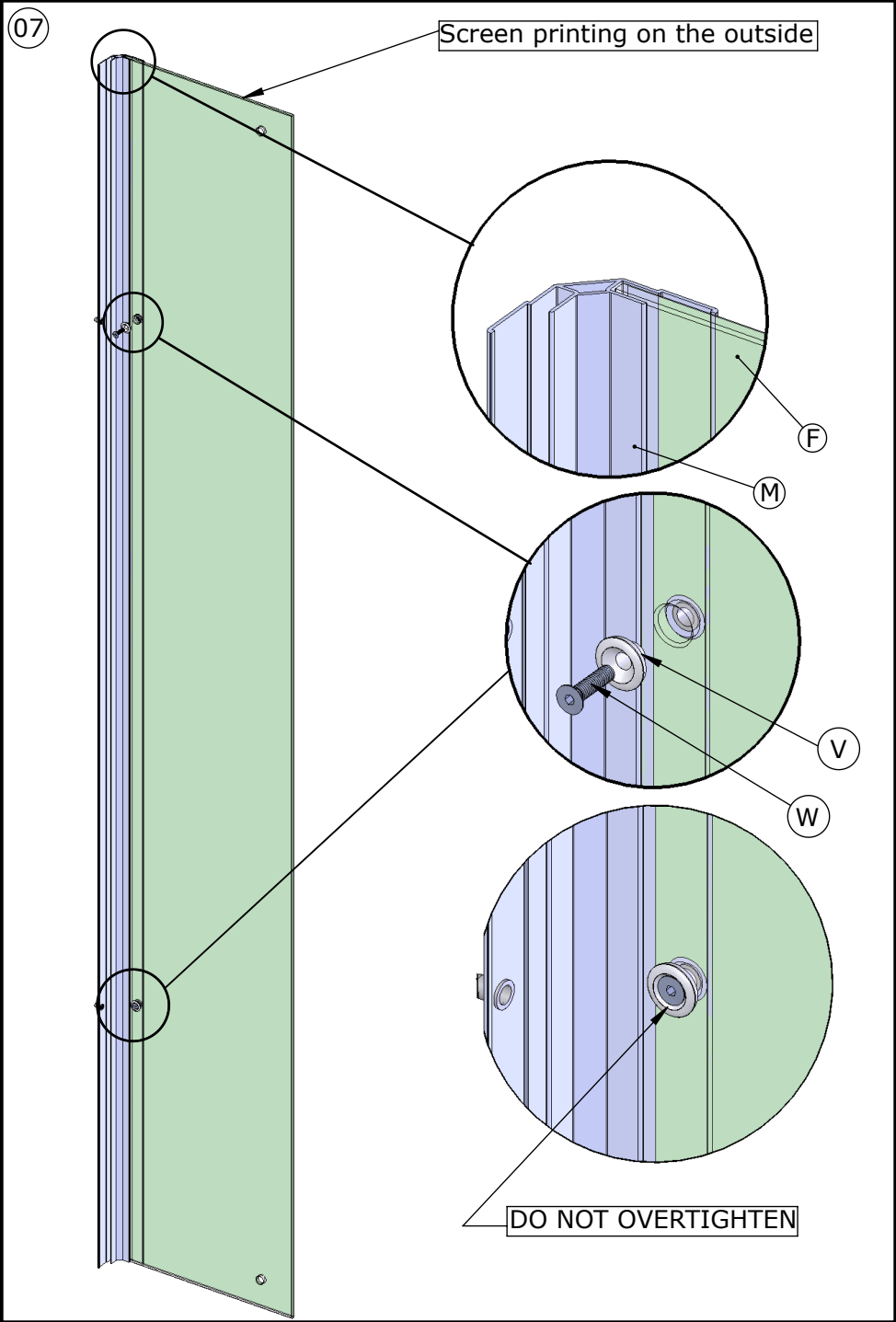

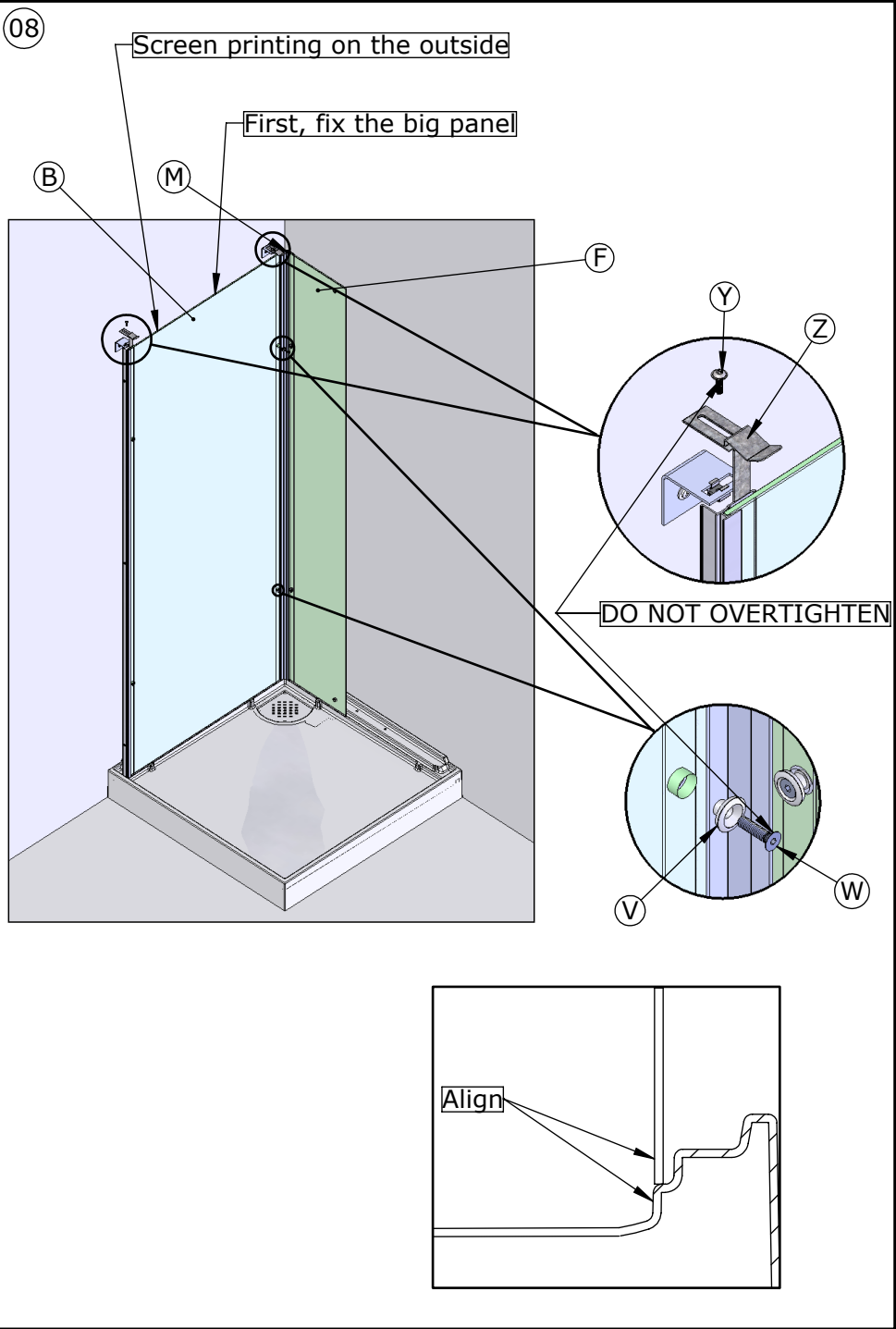

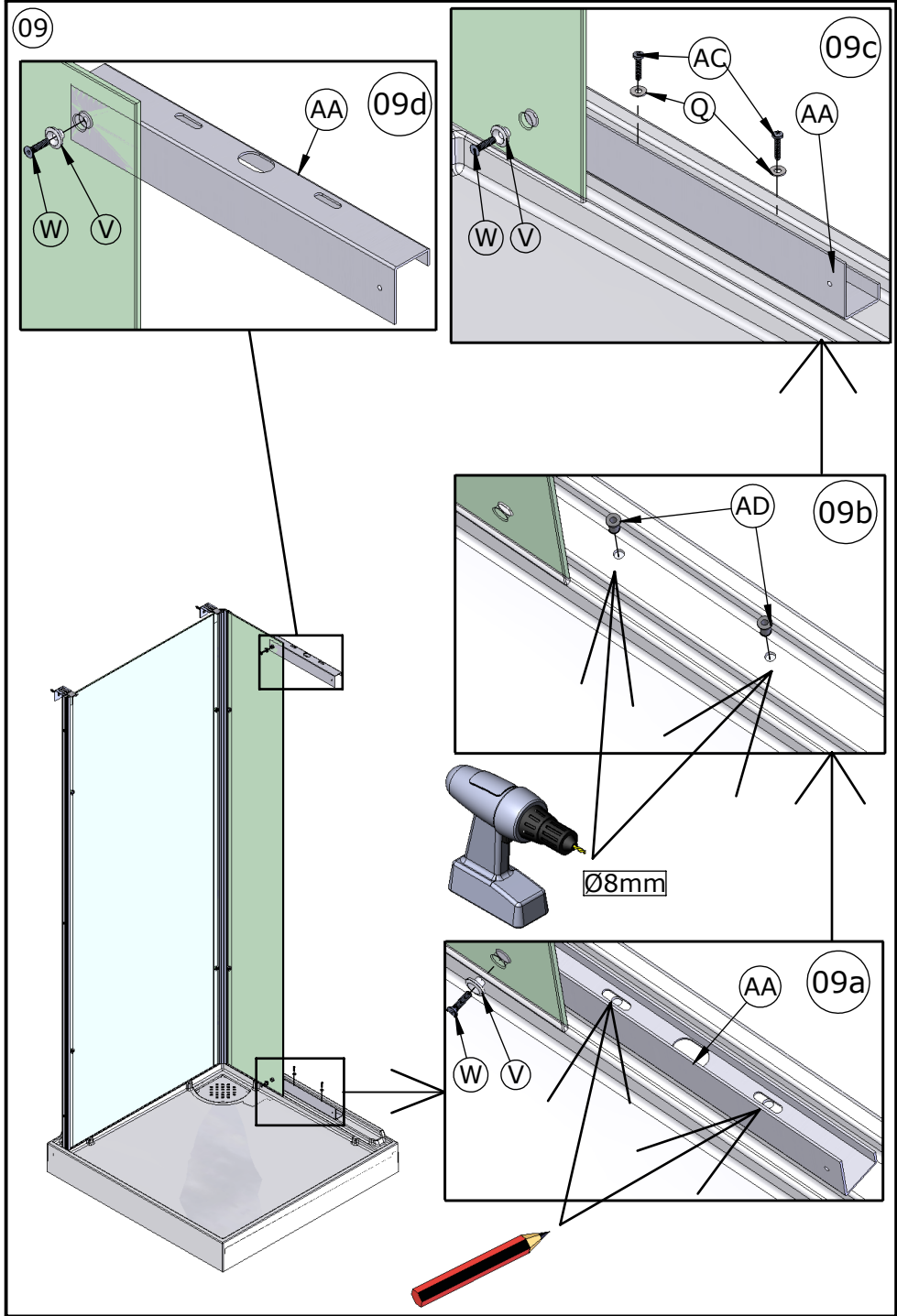

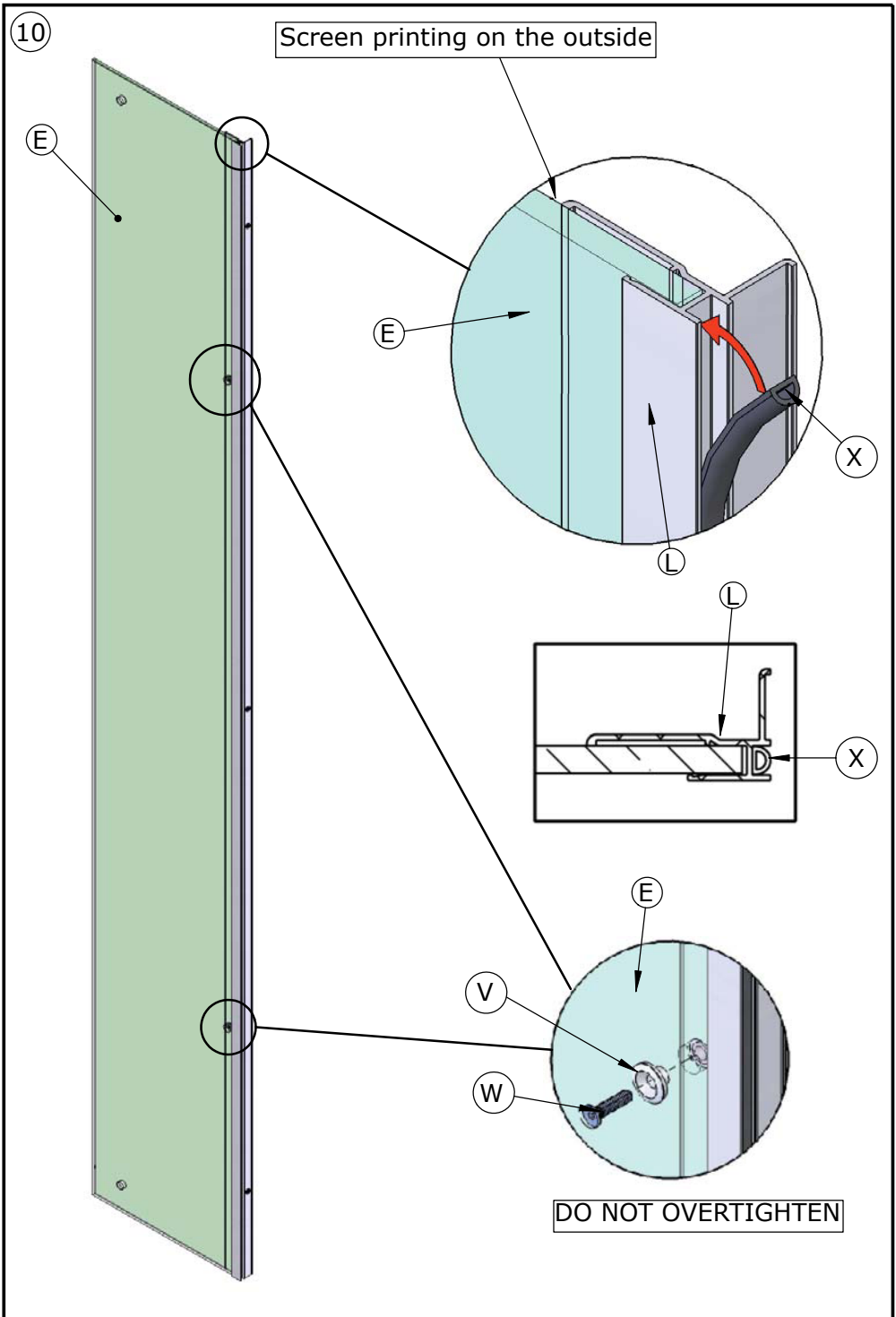

11

Screen printing on the outside

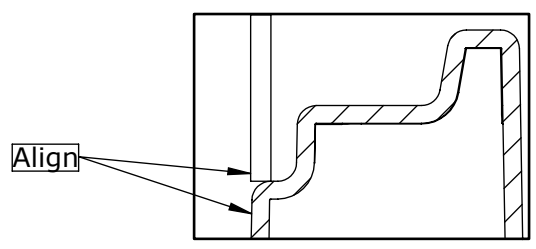
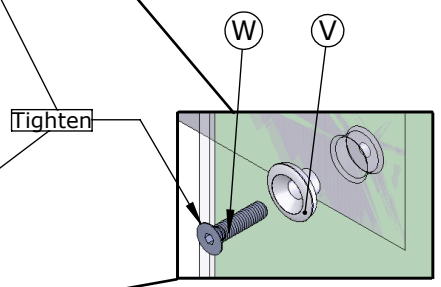
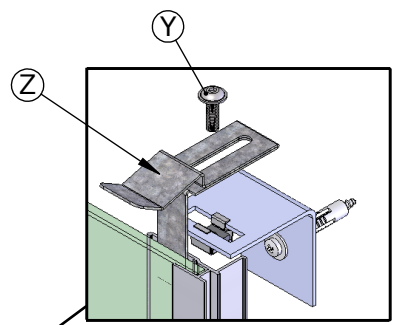
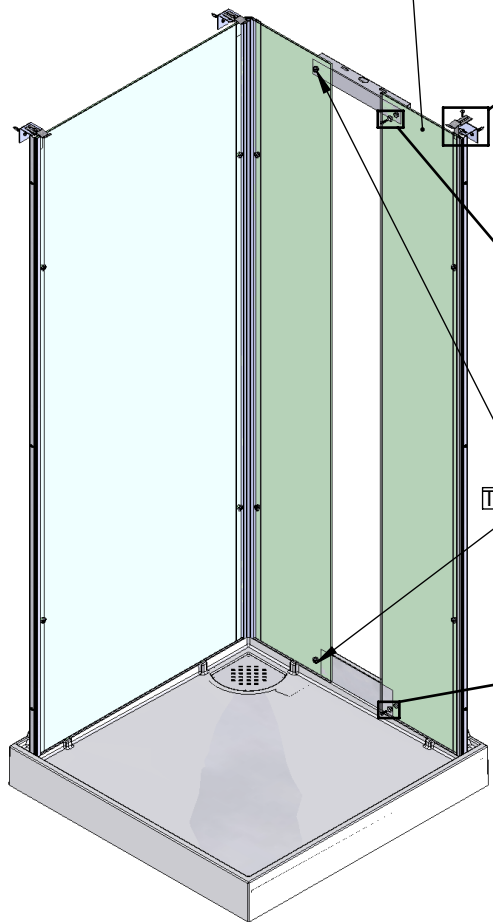

12

Screen printing inside

Drill holes on top

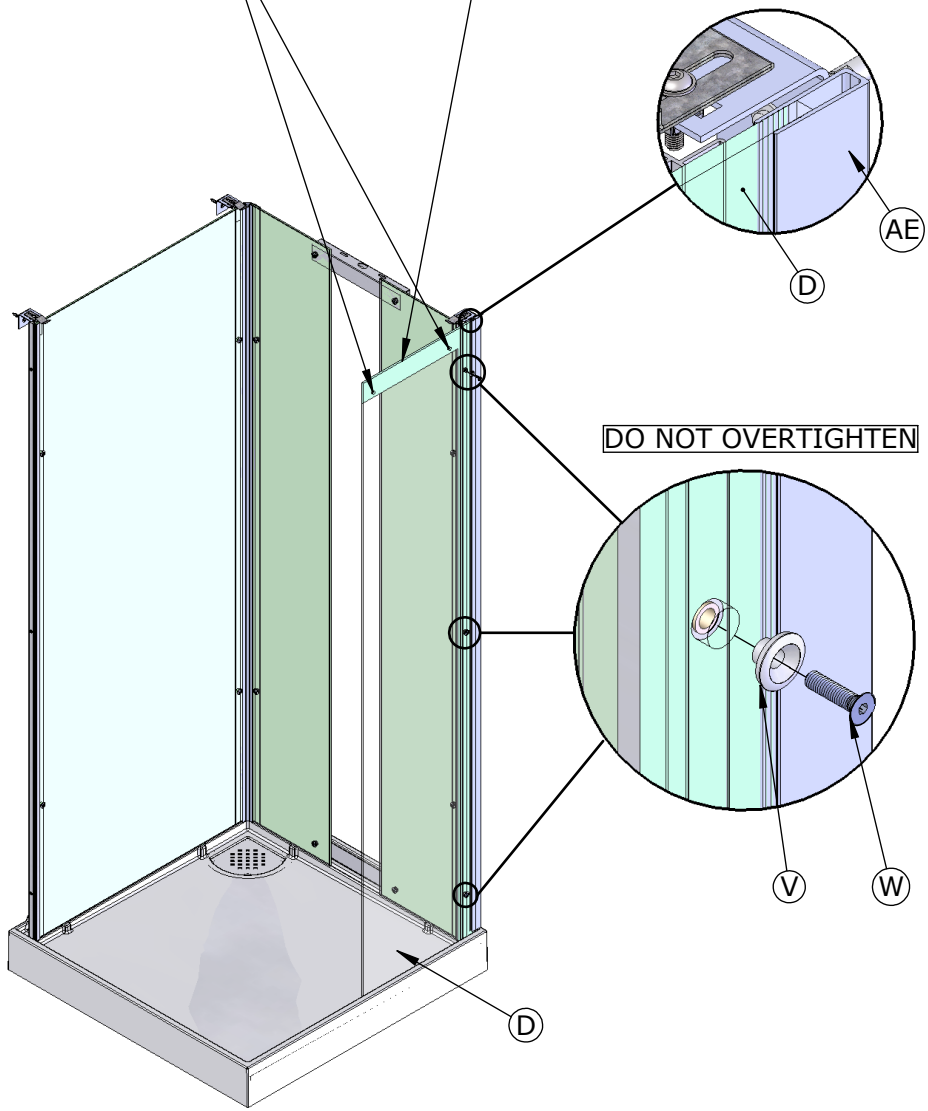

DO NOT OVERTIGHTEN

13

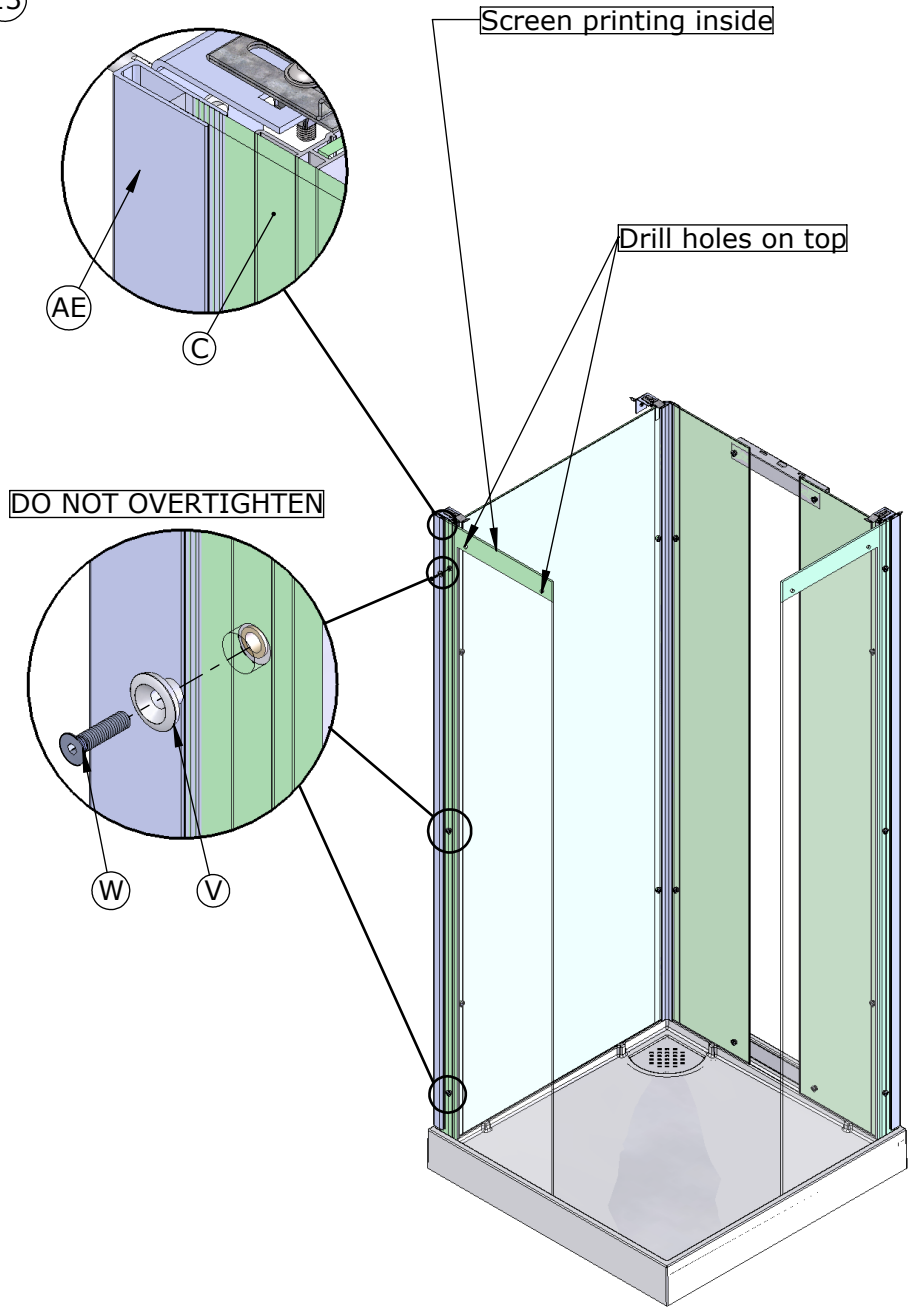

14

Template for the correct positioning

Ø8 mm

AF

C

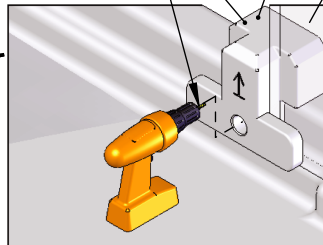

AC

AG

AD

C

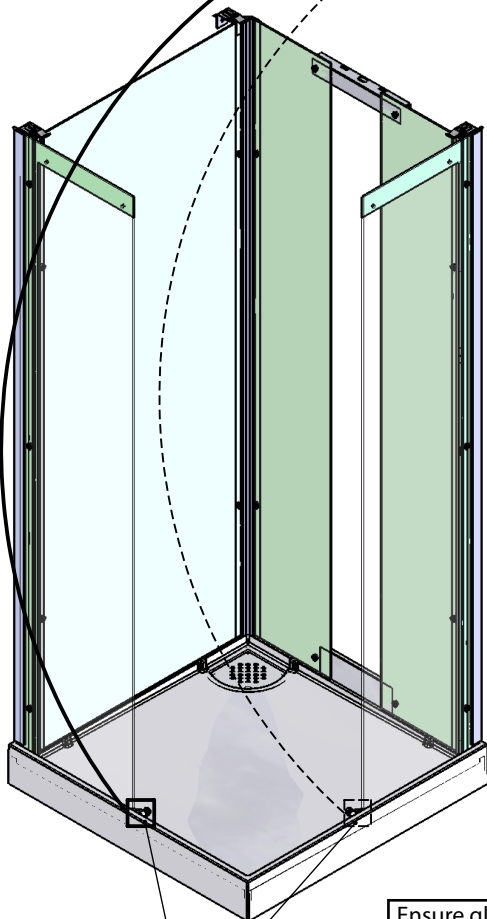
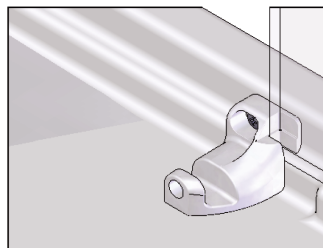
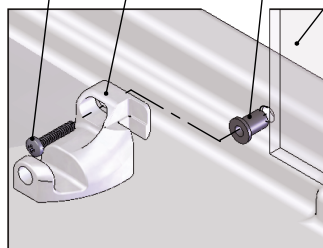

Ensure glass panels are fully home before drilling

AG

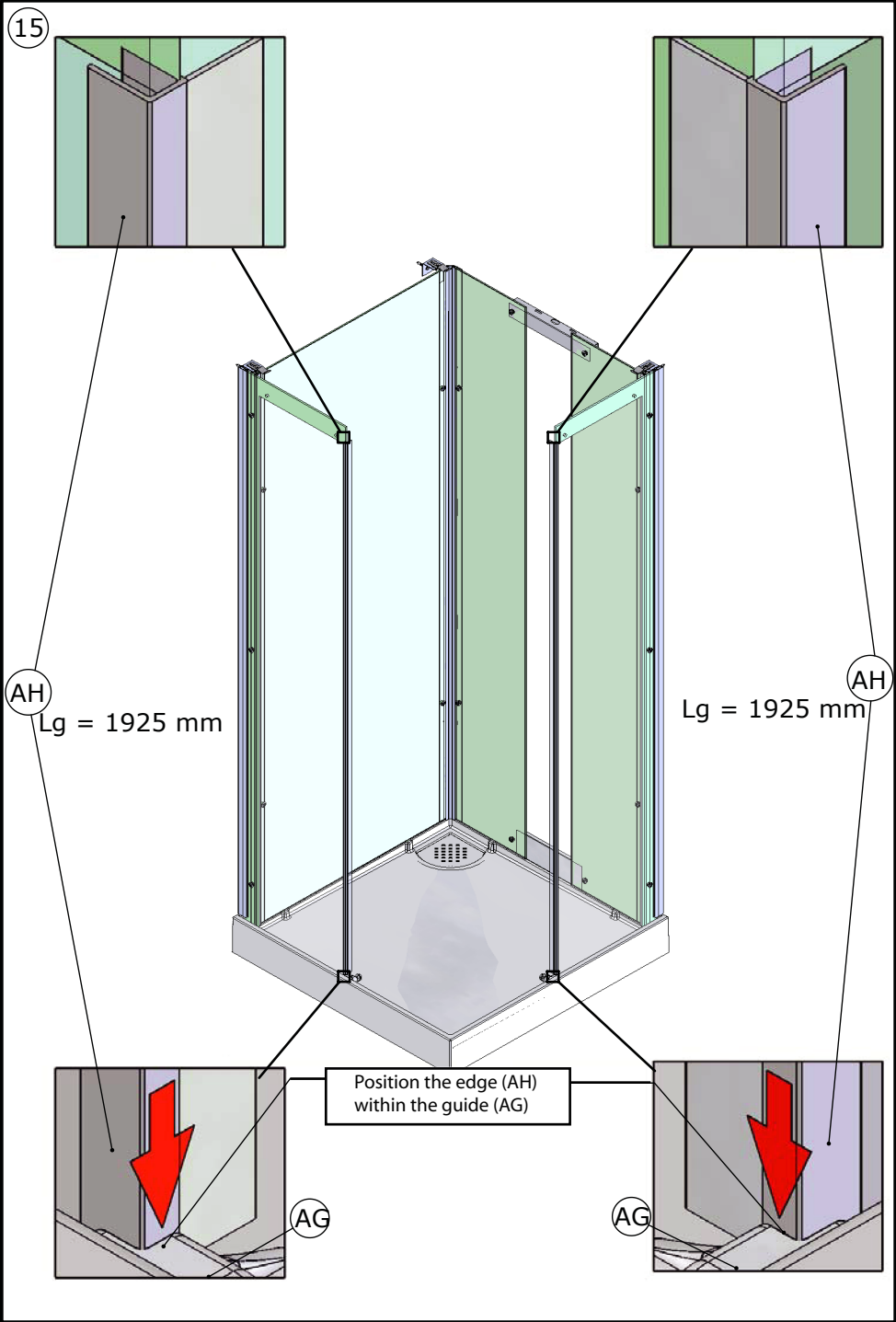

16

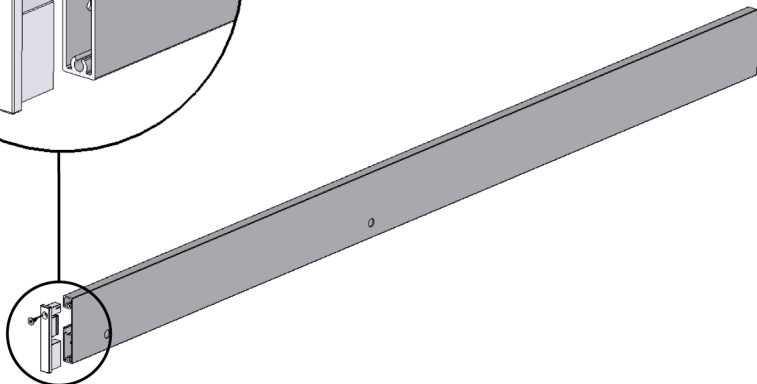
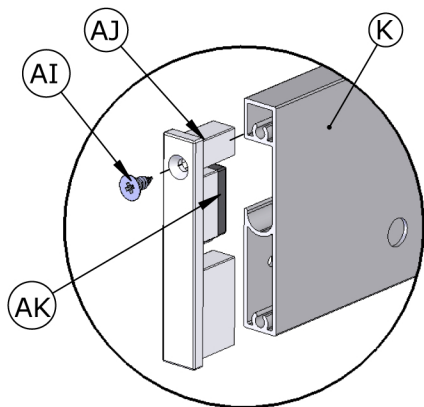
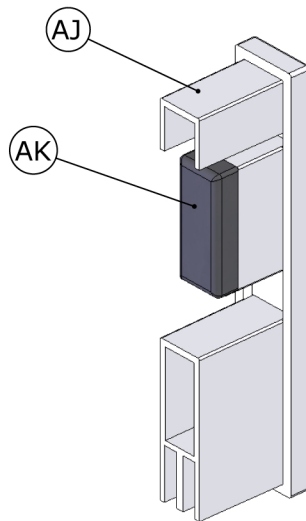
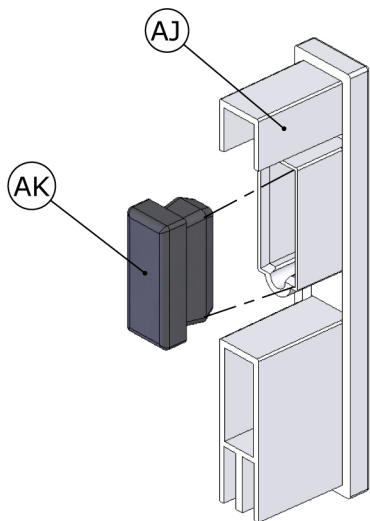

17

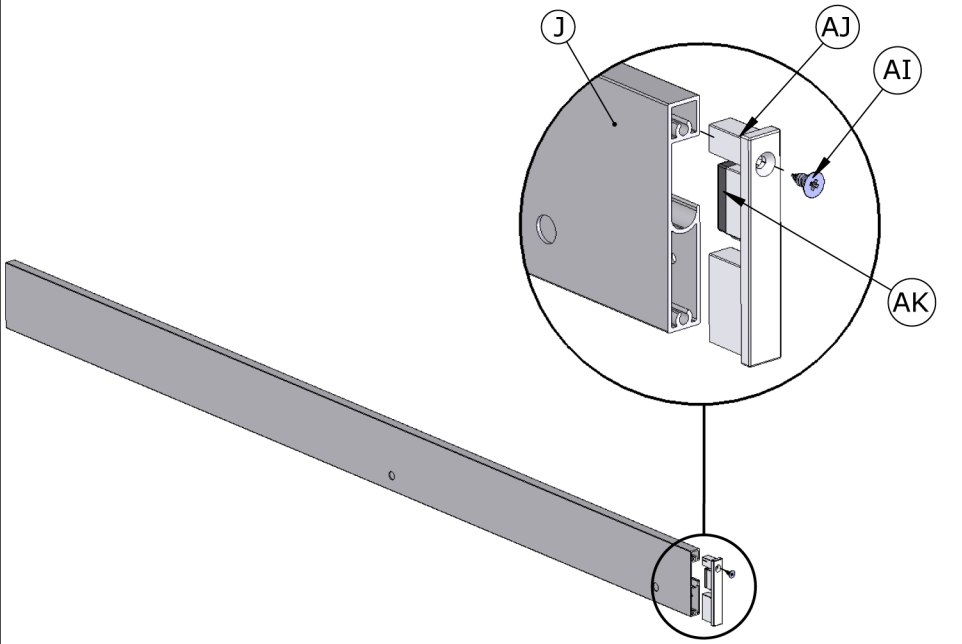
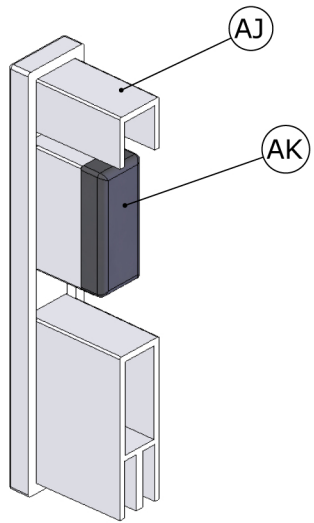
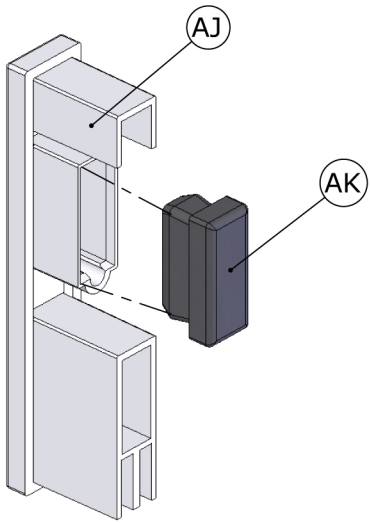

18

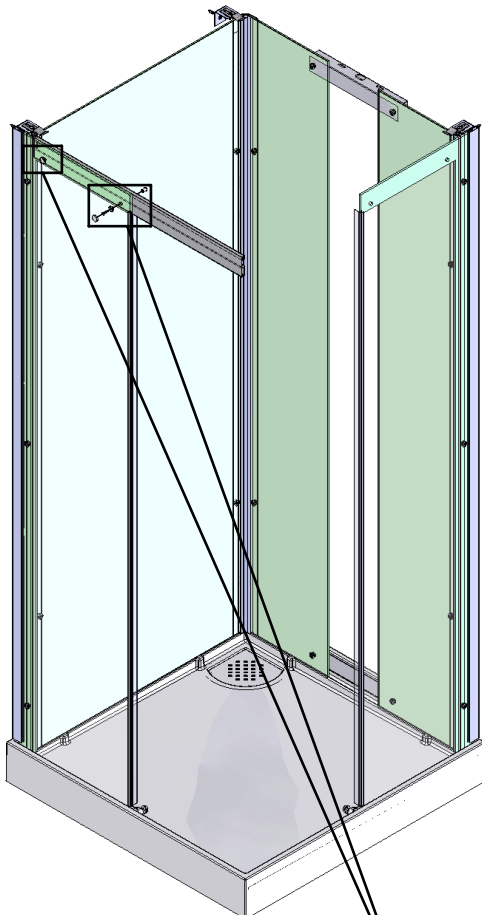

(K) is inside the shower

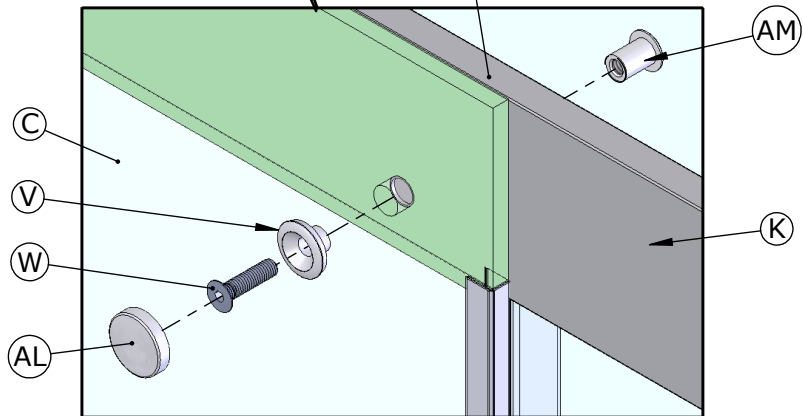

19

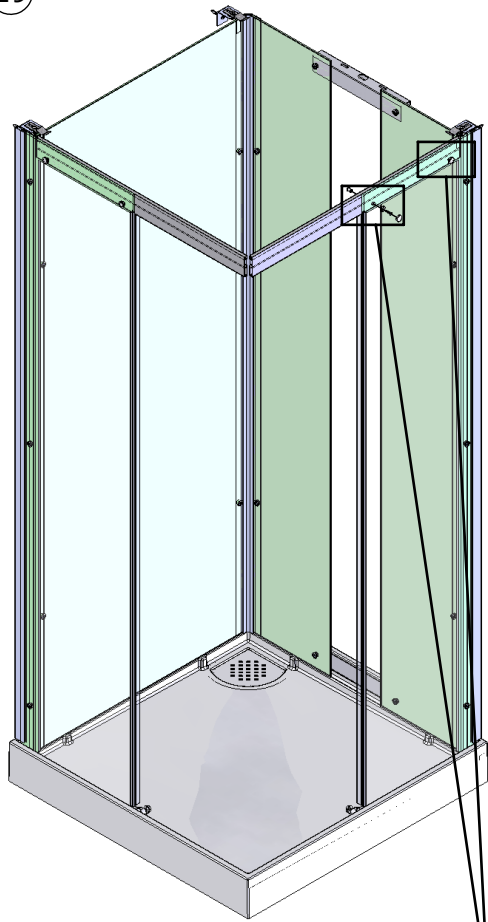

(J) is inside the shower

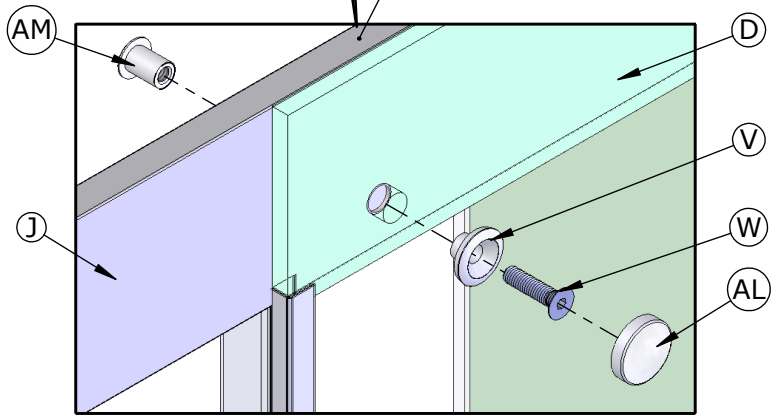

20

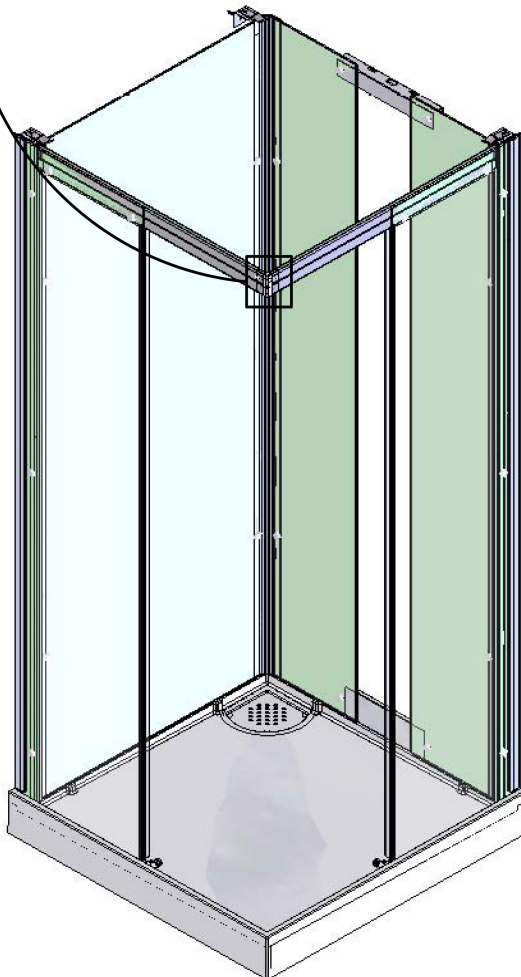
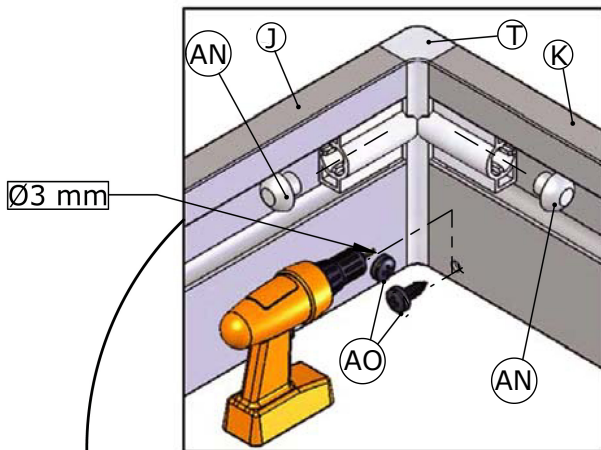

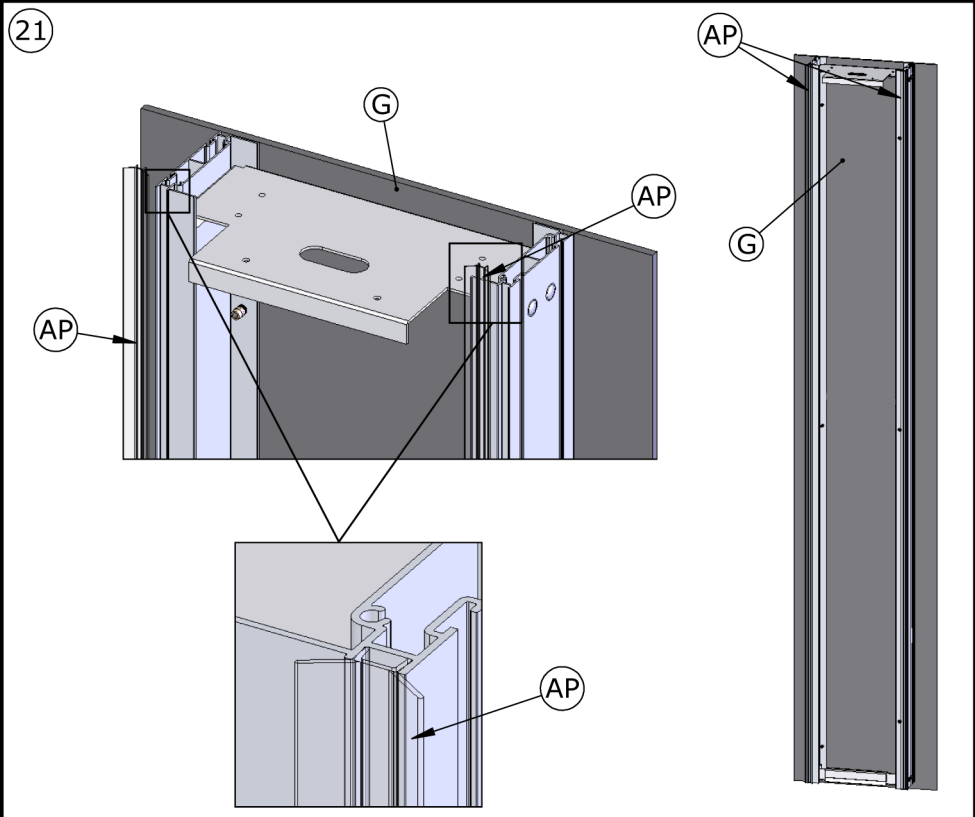

INSTALL THE TAP

22

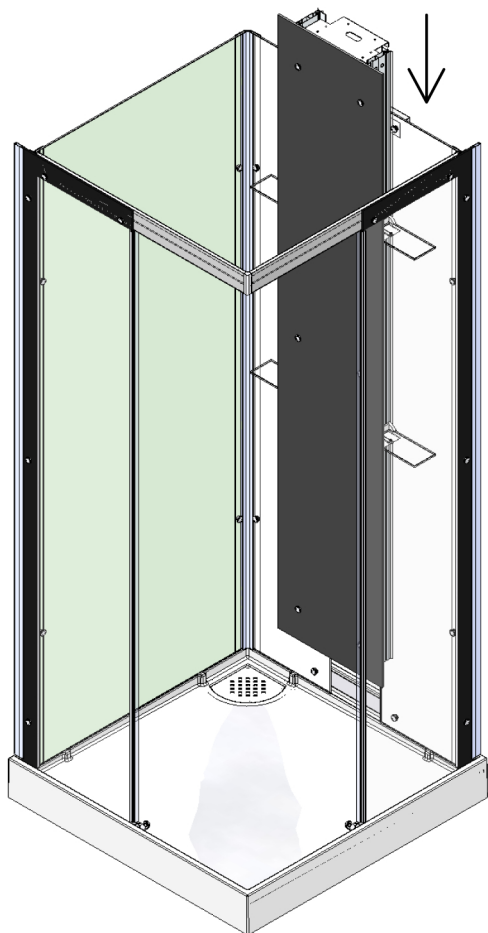
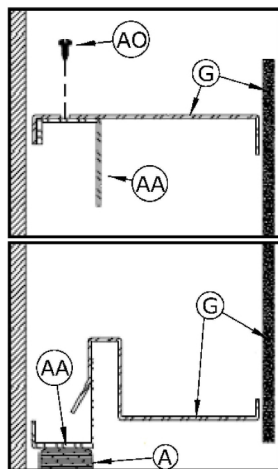
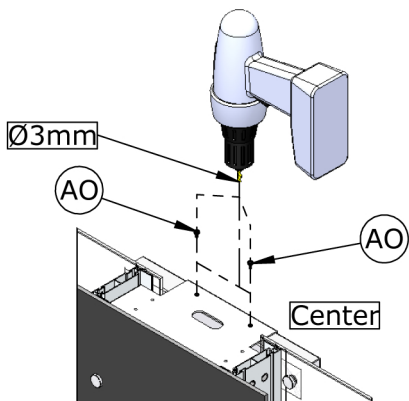

CONNECT THE
WATER SUPPLY
AND CHECK LEAKS
AT THIS POINT
AND CONNECT
EARTH CONECTOR

23

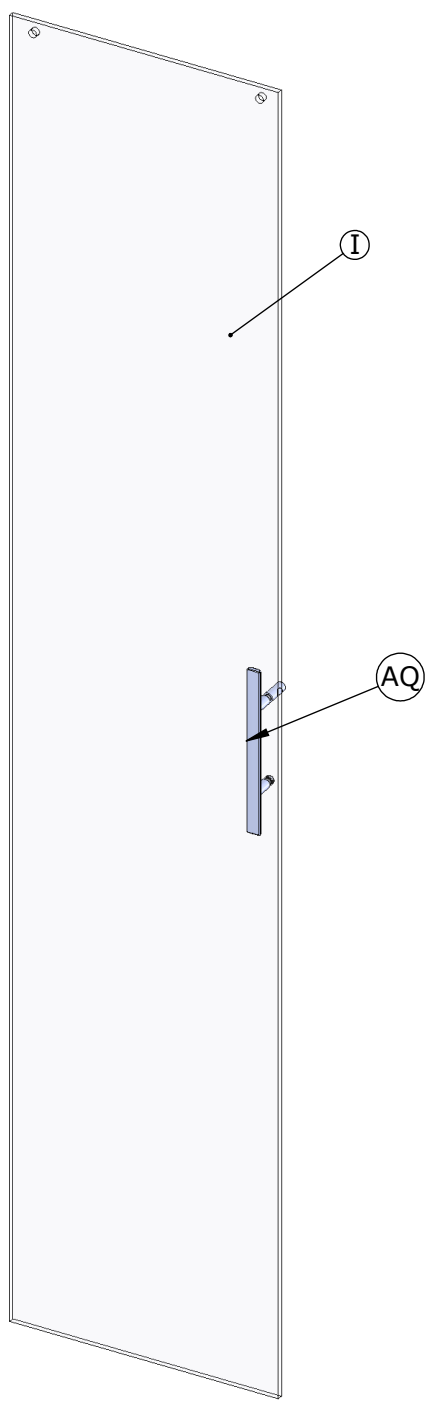

24

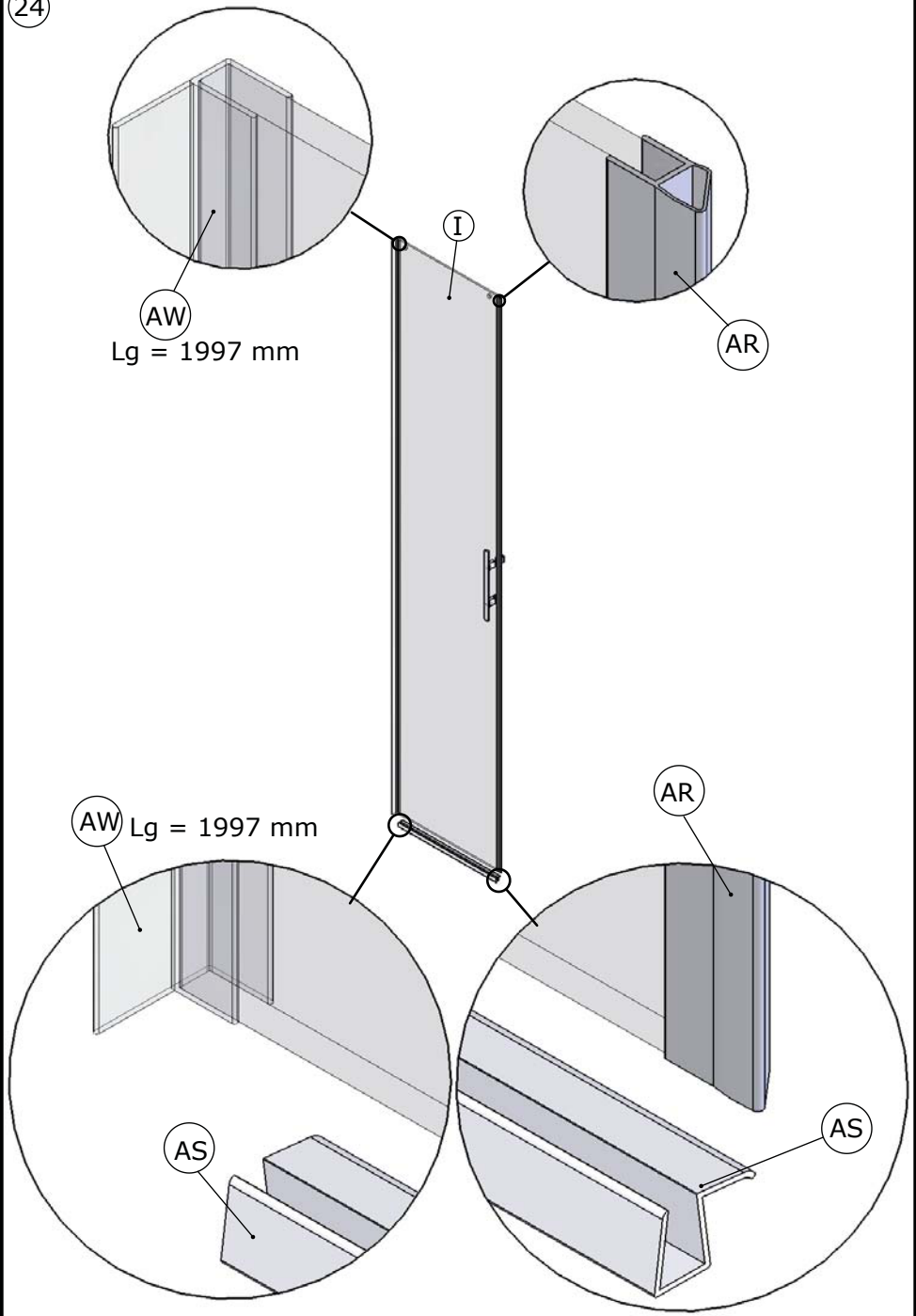

25

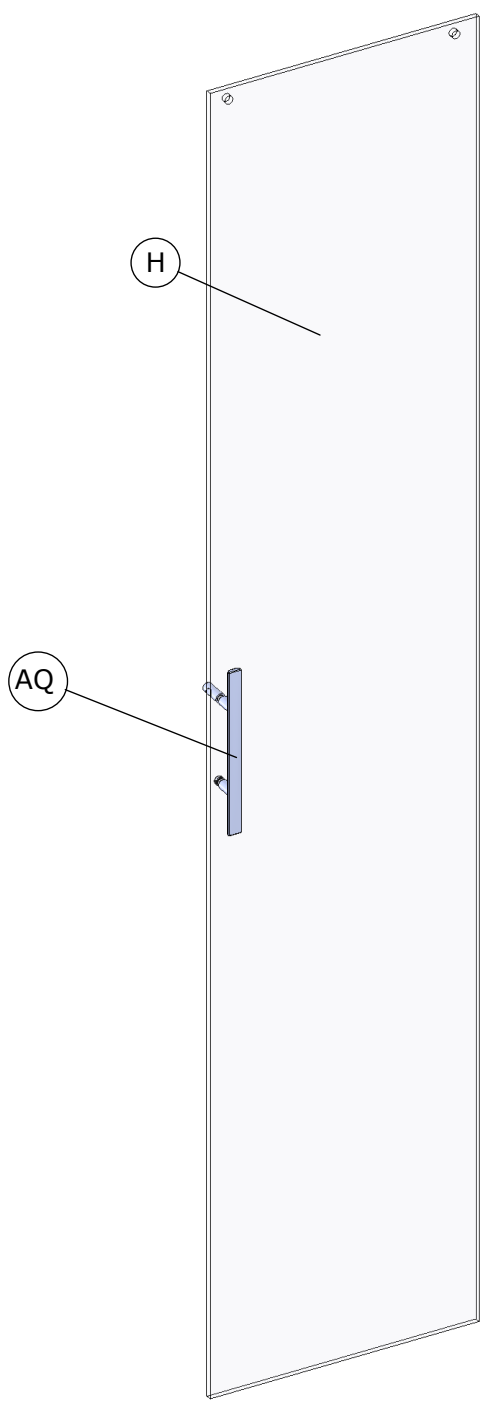

26

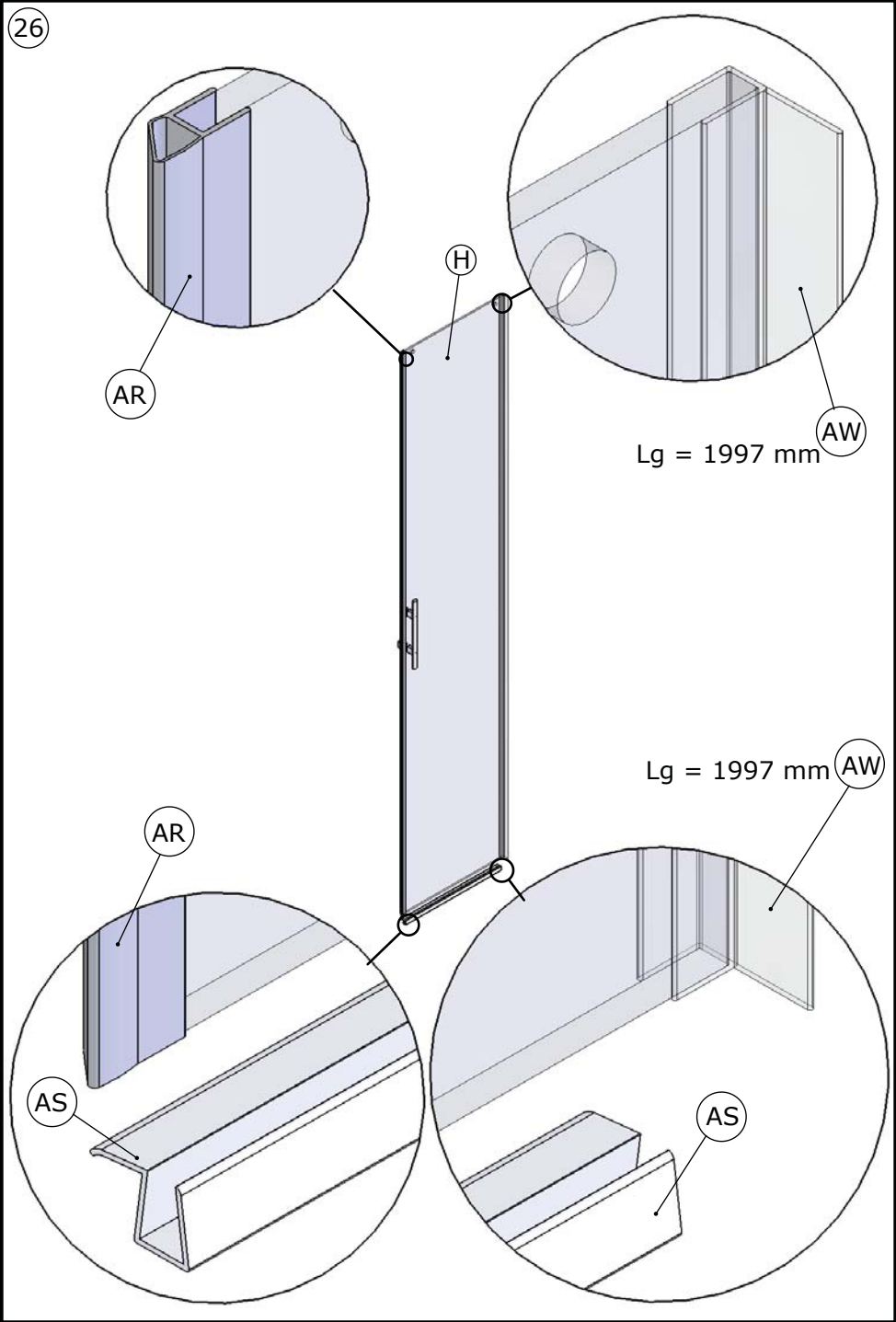

27

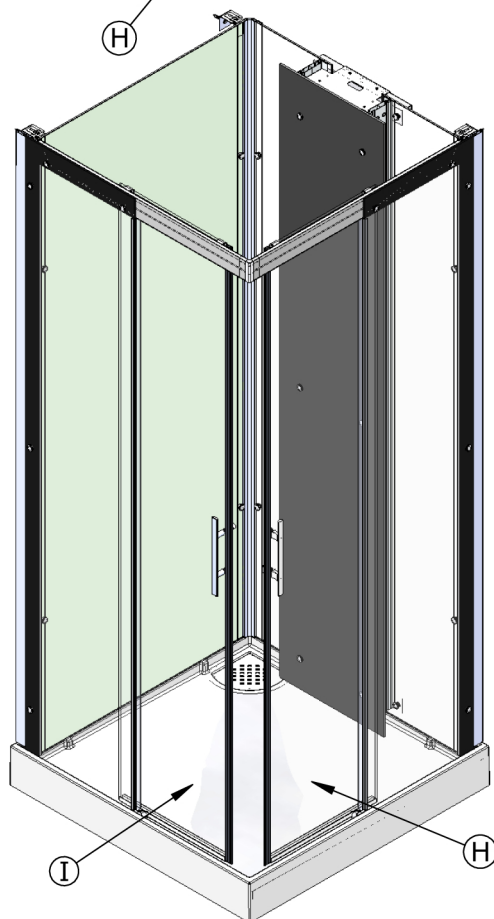
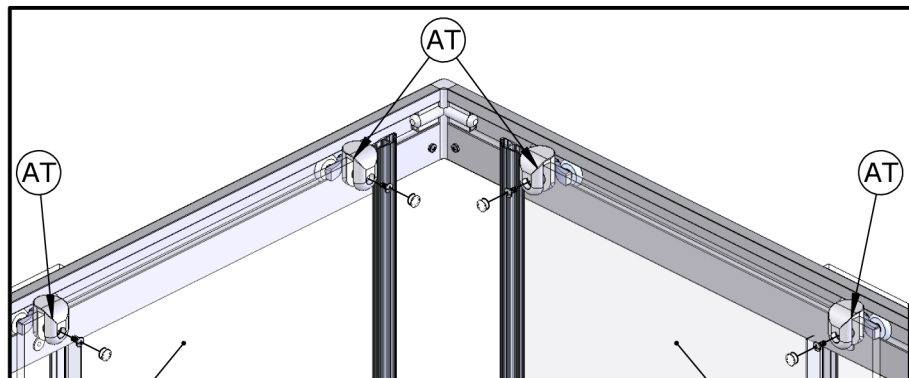

Place the rollers into the top rail then attach the doors to the rollers. Ensure rollers are at the highest adjustment.

28

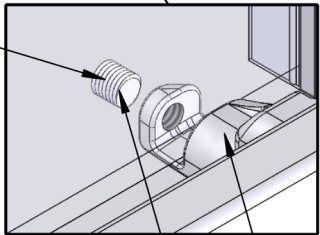
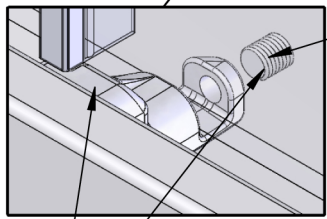
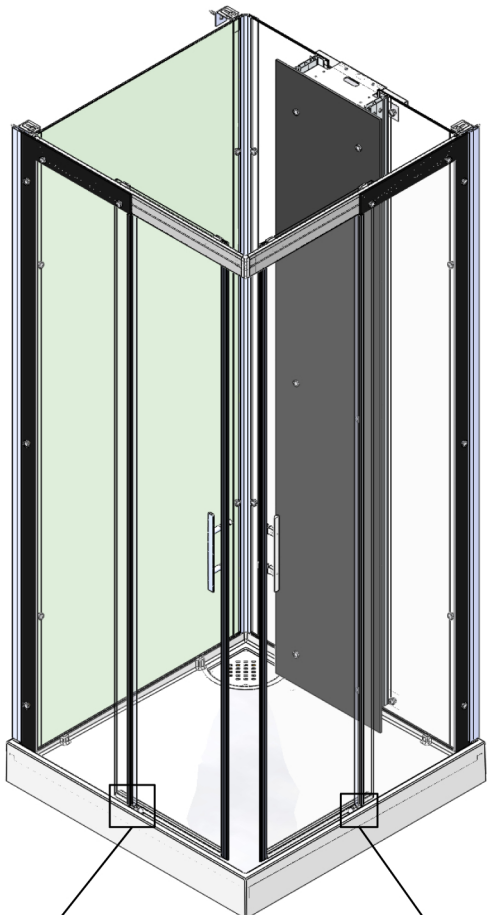

AU

AG

AG

Hand tighten then unscrew half a turn

29

Check that the cubicle is level

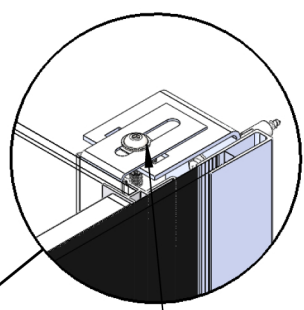
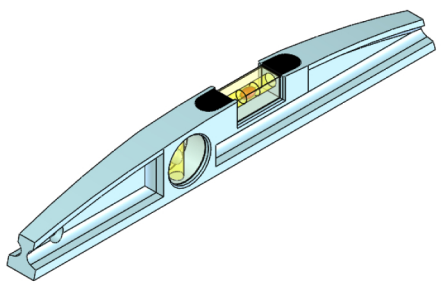

Tighten

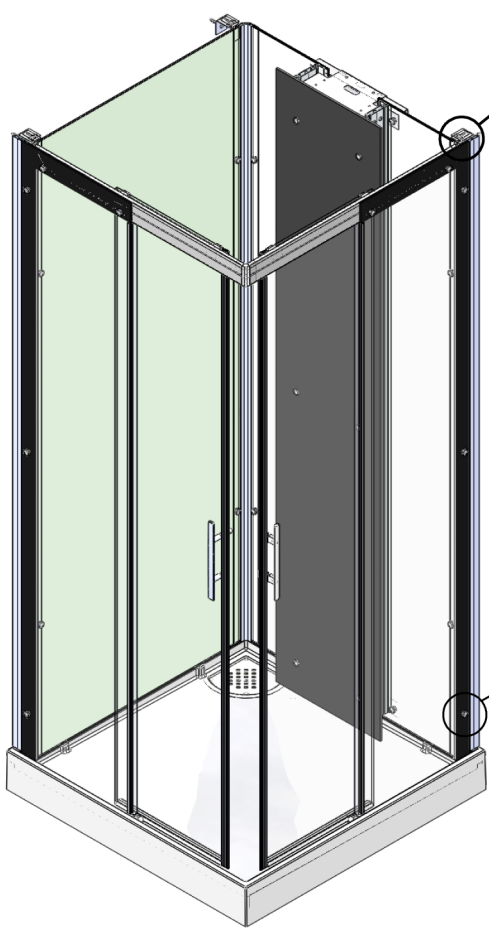

X18

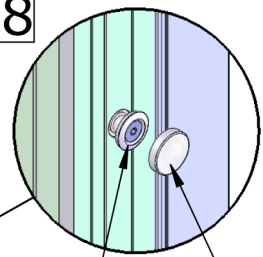

AL

Tighten

30

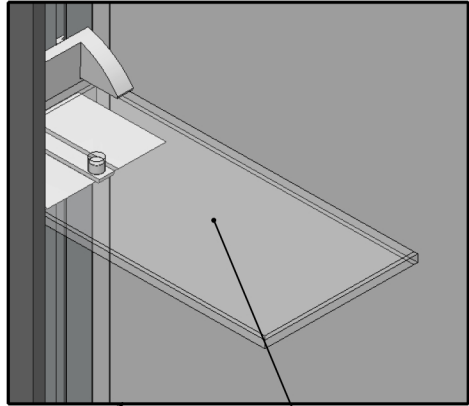

AV

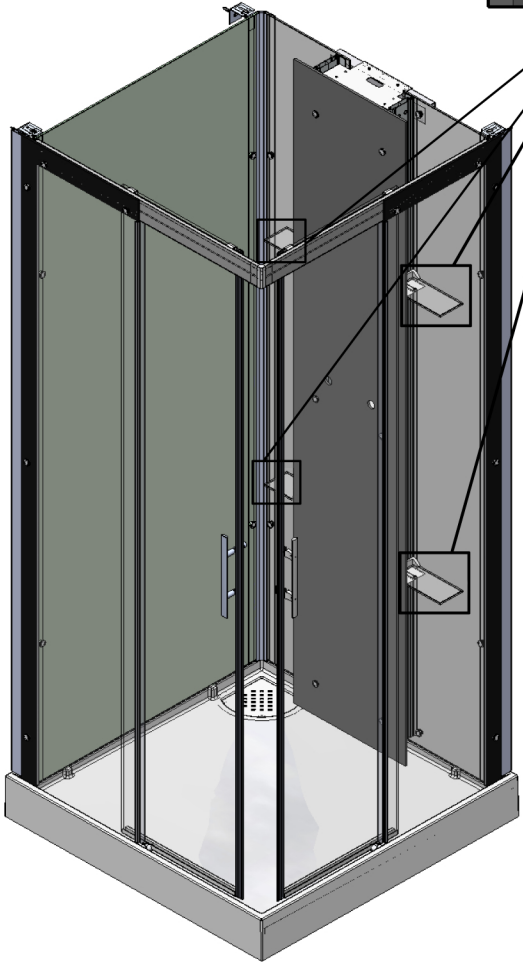

31

Adjust the doors

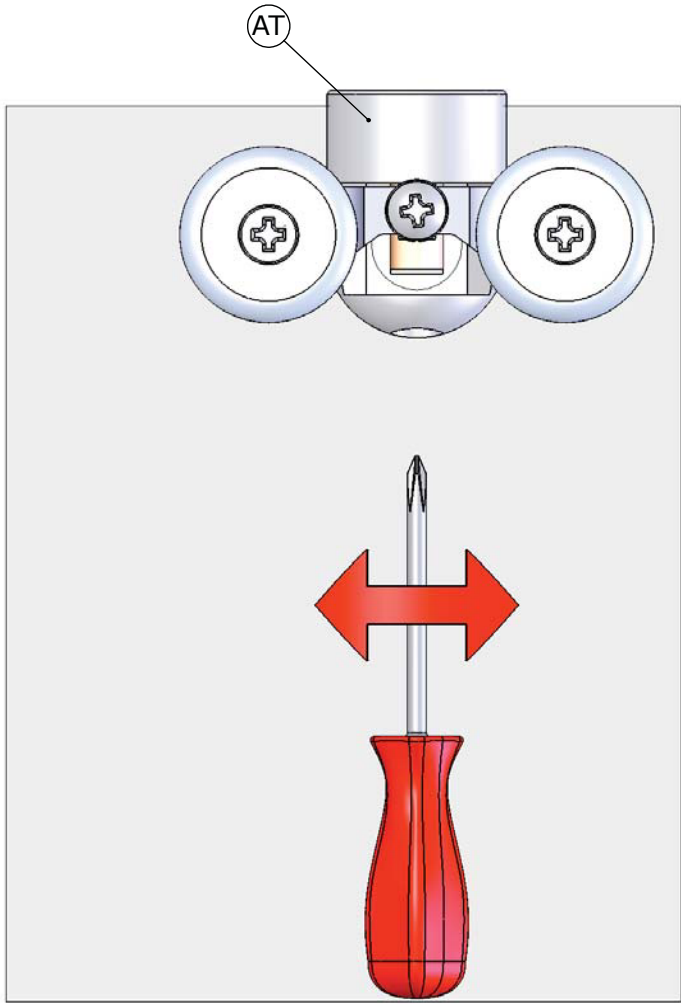

REGLAGE DES ETAGERES
ADJUSTMENT OF SHELVES
REGOLAZIONE MENSOLE
AJUSTE DE LAS ESTANTERIAS
VERSTELBARE REKKEN

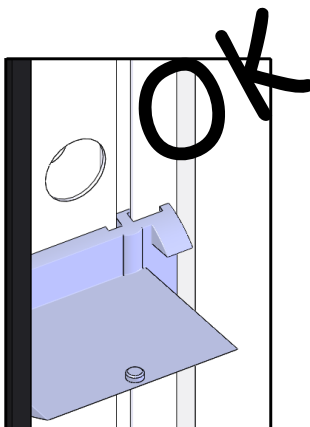
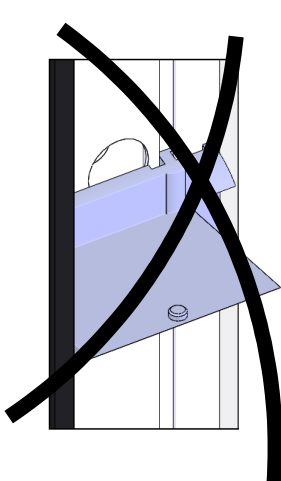
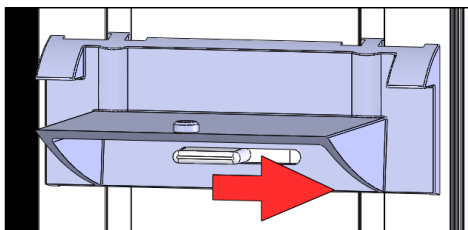
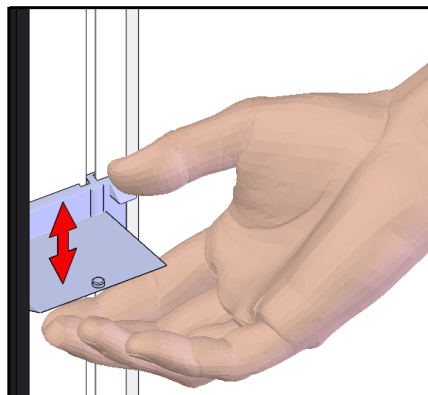
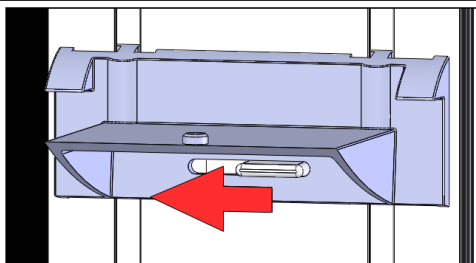



SAV
SERVICE HELPLINES
ASSISTENZA POST-VENDITA
SERVICIO POSTVENTA

FRANCE

02 40 21 29 45

SCHWEIZ

(01) 748 17 44

UK

020 8842 0033

ESPANA

93 544 60 76

IRELAND

04697 33102

NEDERLAND

0475 487 100

DEUTSCHLAND

+49 (0) 6074 / 30928 0

BELGIE

+31 475 487 100

ITALIA

(0382) 6181

BELGIQUE

+31 475 487 100

OSTEREICH

+43 1 710 60 70

РОССИЯ

963 19 40, 773 67 22