

Kinedo

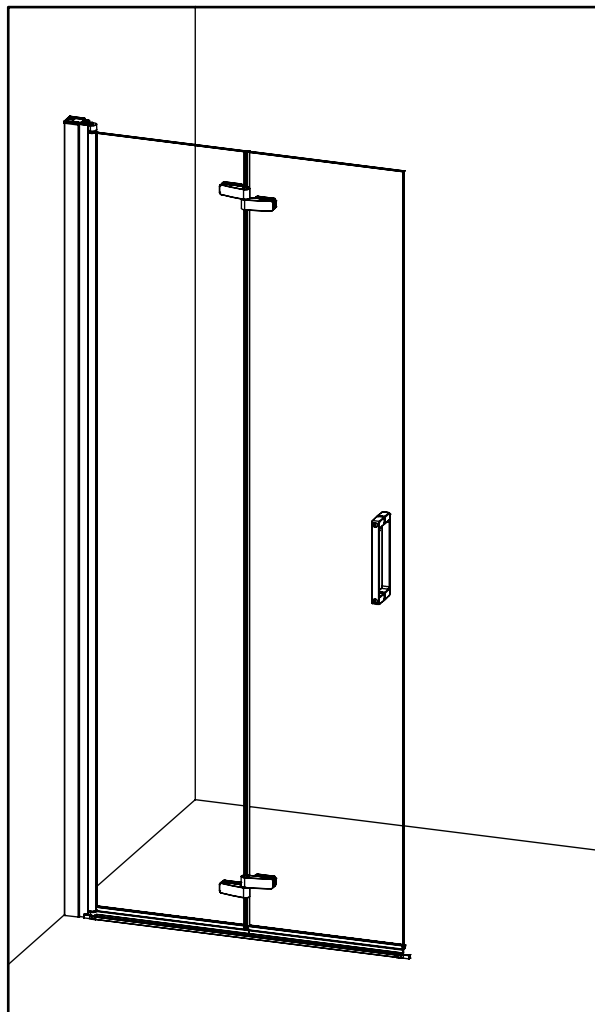





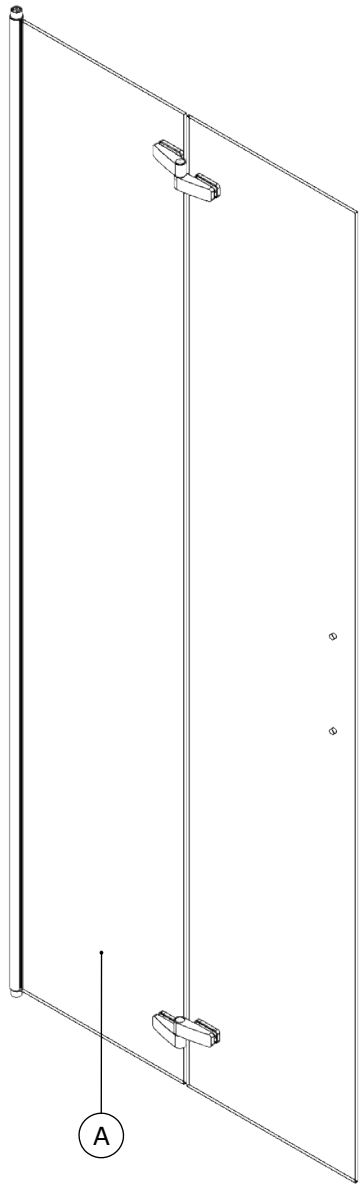

DES1394-C

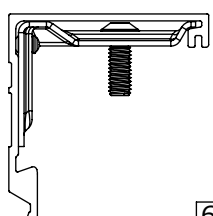

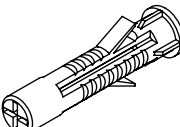
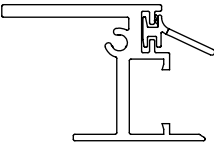
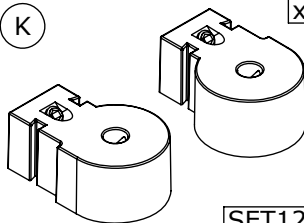
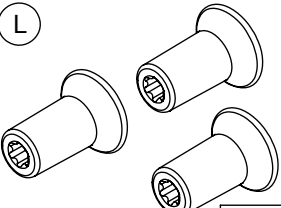
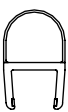
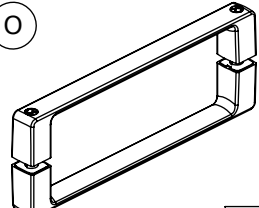
NOTICE DE MONTAGE / INSTALLATION INSTRUCTIONS / MANUAL DE INSTALACIÓN / MANUAL DE INSTALAÇÃO
ISTRUZIONI DI MONTAGGIO / INSTALLATIE VOORSCHRIFTEN / INSTALLATIONSANLEITUNG

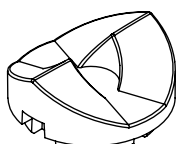
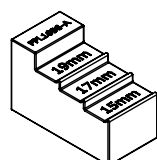
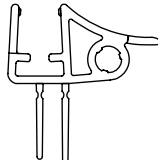

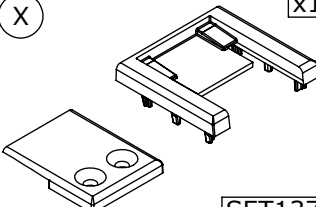
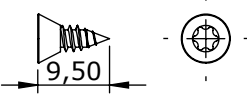

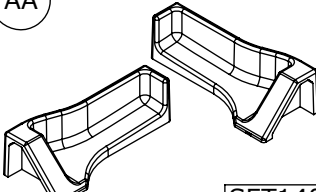
<p>G x1</p>  <p style="text-align: right;">6268</p>	<p>H Ø4 x3</p>  <p style="text-align: center;">45</p> <p style="text-align: right;">VIS231</p>	
<p>I x3</p>  <p style="text-align: right;">CHE02</p>	<p>J x1</p>  <p style="text-align: right;">6272</p>	<p>K x1</p>  <p style="text-align: right;">SET128</p>
<p>L x1</p>  <p style="text-align: right;">SET134</p>	<p>M x1</p>  <p>Lg=1962mm J808</p>	<p>O x1</p>  <p style="text-align: right;">PGN49</p>
<p>P x2</p>  <p style="text-align: right;">BUT44</p>	<p>Q x1</p>  <p style="text-align: right;">PPL1248</p>	<p>R x2</p>  <p style="text-align: right;">PPL1696</p>
<p>T x2</p>  <p>Lg=1100mm J806</p>	<p>W x1</p>  <p style="text-align: right;">6270</p>	<p>X x1</p>  <p style="text-align: right;">SET137</p>
<p>Y Ø3.5 x1</p>  <p style="text-align: center;">9,50</p> <p style="text-align: right;">VIS261</p>	<p>Z x1</p>  <p style="text-align: right;">6285</p>	<p>AA x1</p>  <p style="text-align: right;">SET140</p>

● Les quantités données sont les quantités utiles au montage, les sachets fournis contiennent des pièces supplémentaires.

● The quantities given are what are required for the installation. There may be some surplus in the package provide.

● Outillage nécessaire ● Tools required ● Equipamiento necesario
 ● Attrezzatura necessaria ● Benodigde gereedschap ● Werkzeuge erforderlich

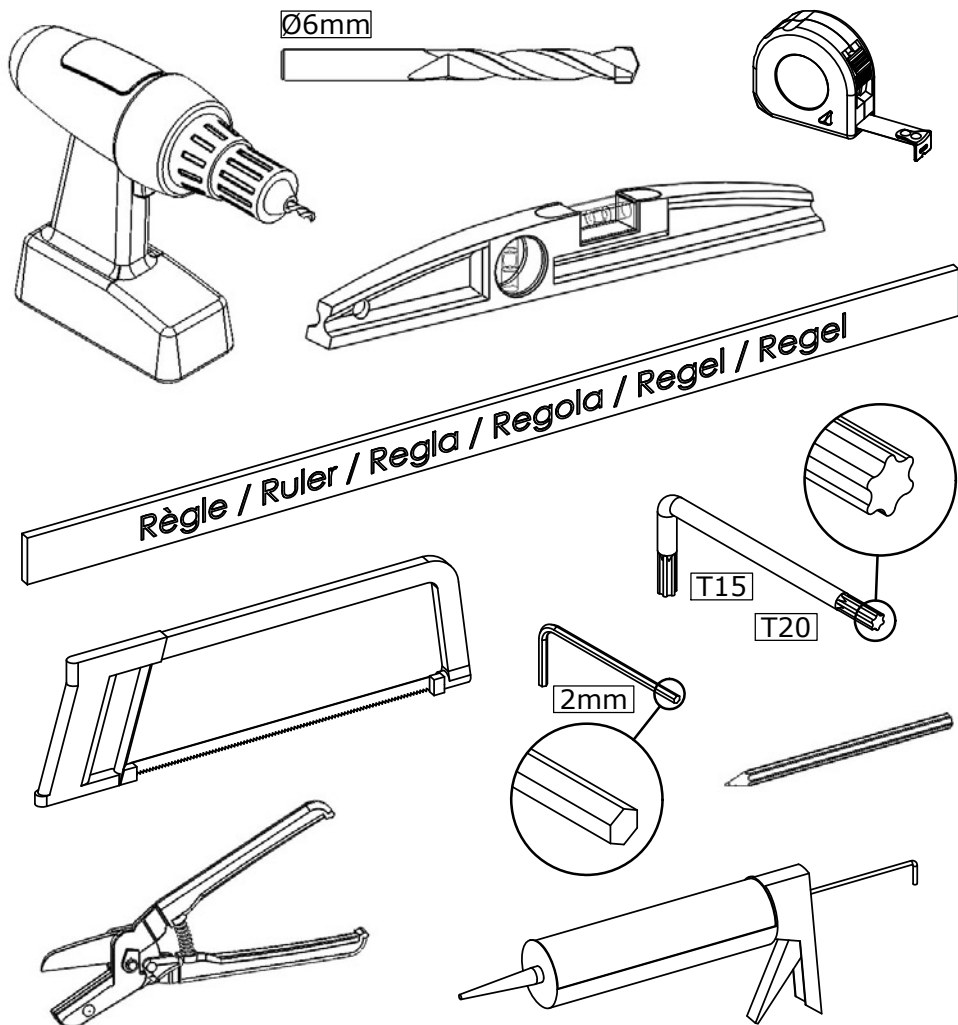

- Utiliser un silicone adapté au matériau de chaque support (faïence, acrylique, etc.)
- Use a silicone sealant that is intended for the surrounding materials (ceramic, acrylic, etc.)
 - Usar una silicona adecuada para cada tipo de material (loza, acrílico, etc.)
 - Utilizzare un silicone adatto a qualsiasi materiale (ceramica, acrilico, ecc.)
- Gebruik siliconenkit die geschikt is voor iedere ondergrond (tegelwerk, acryl, etc.)
- Für das jeweilige Trägermaterial (Stein, Acryl usw.) geeignetes Silikon verwenden.



F REVERSIBILITE **GB** REVERSIBILITY **E** REVERSIBILIDAD
I REVERSIBILITA **NL** OMKEERBAARHEID **D** WAHLWEISE MONTAGE

F MONTAGE A GAUCHE
GB LEFT HAND
E MONTAJE A LA IZQUIERDA
I MONTAGGIO A SINISTRA
NL MONTAGE LINKS
D MONTAGE LINKS

F MONTAGE A DROITE
GB RIGHT HAND
E MONTAJE A LA DERECHA
I MONTAGGIO A DESTRA
NL MONTAGE RECHTS
D MONTAGE RECHTS

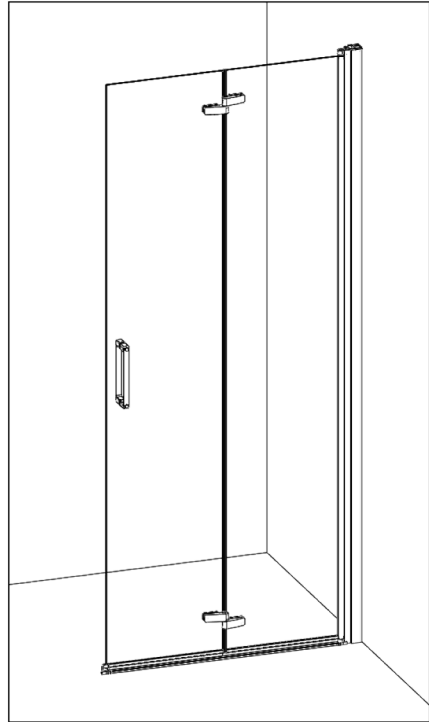
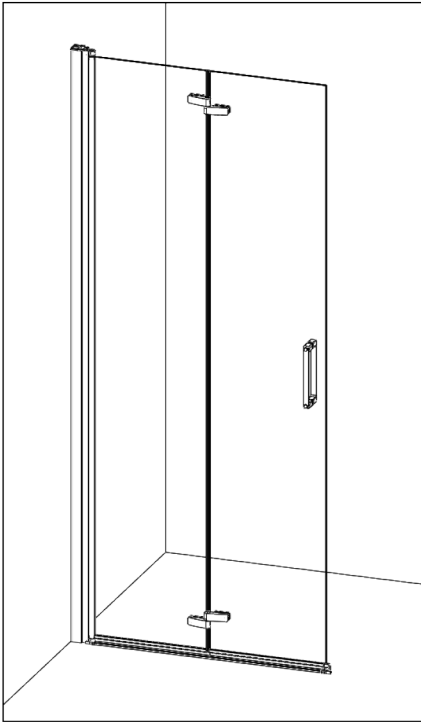

F Vous avez la possibilité de réaliser un montage à droite ou un montage à gauche. Notre notice d'installation décrit un montage à gauche. Si vous voulez réaliser un montage à droite, il vous suffit d'inverser le montage.

GB This cubicle can be installed either left or right hand. These installation instructions show a left hand installation.

E Puede realizar un montaje a la derecha o un montaje a la izquierda. Nuestro folleto de instalación describe un montaje a la izquierda. Si desea montar su cabina a la derecha sólo tendrá que realizar el montaje al contrario.

I Avete la possibilità di effettuare il montaggio a destra o a sinistra. Il nostro manuale descrive il montaggio a sinistra. Se volete realizzare il montaggio a destra è sufficiente invertire varie fasi di montaggio.

NL U kunt de douchecabine rechts of links monteren. Onze handleiding beschrijft de links montage van de cabine. Keer de montage om als u de cabine rechts wilt monteren.

D Sie haben die Möglichkeit, eine Montage auf der linken Seite oder eine Montage auf der rechten Seite durchzuführen. Unsere Montageanleitung beschreibt eine Montage auf der linken Seite. Wenn Sie die Montage lieber auf der rechten Seite durchführen wollen, müssen Sie nur den Montageprozess umkehren.

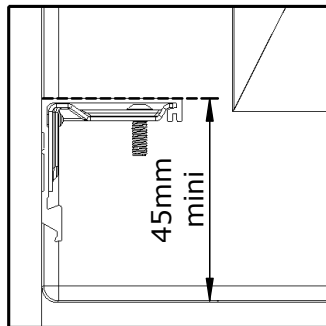
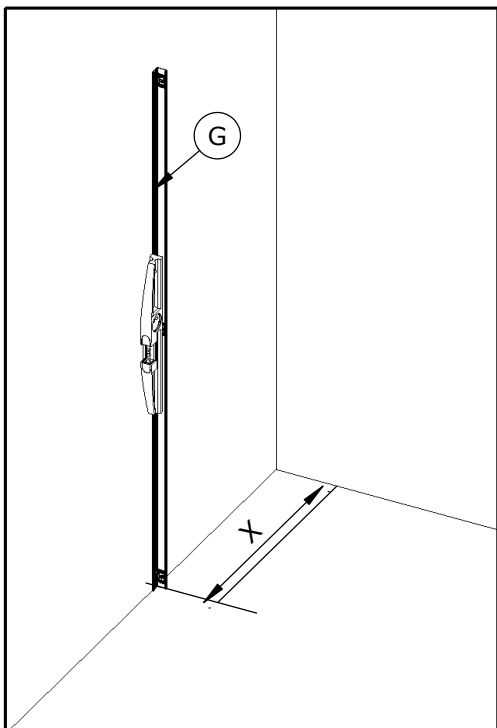

- Si receveur ● If shower tray
- Se piatto
- Als douchebak ● Wenn Duschwanne

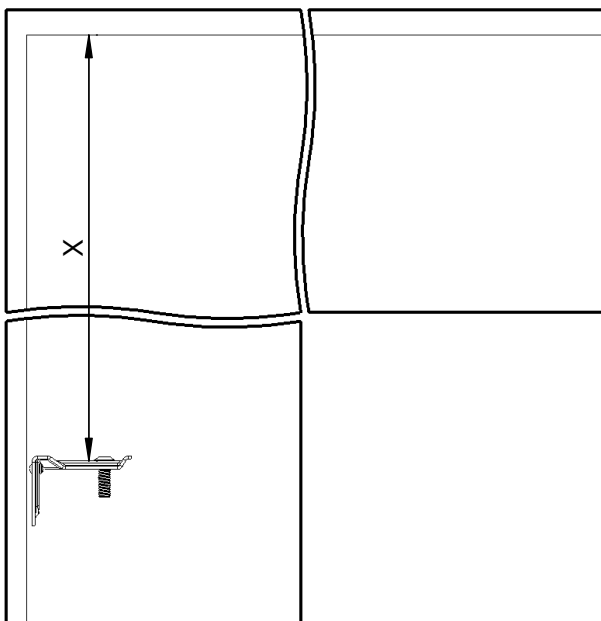

DIMENSIONS	X
70	630 - 645
75	680 - 685
80	730 - 745
85	780 - 785
90	830 - 845
95	880 - 885
100	930 - 945

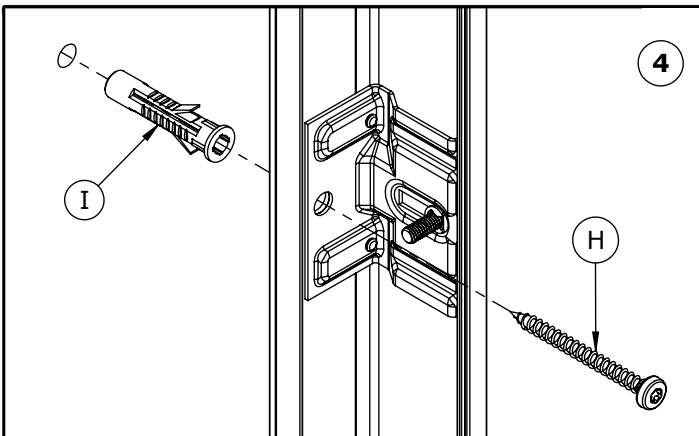
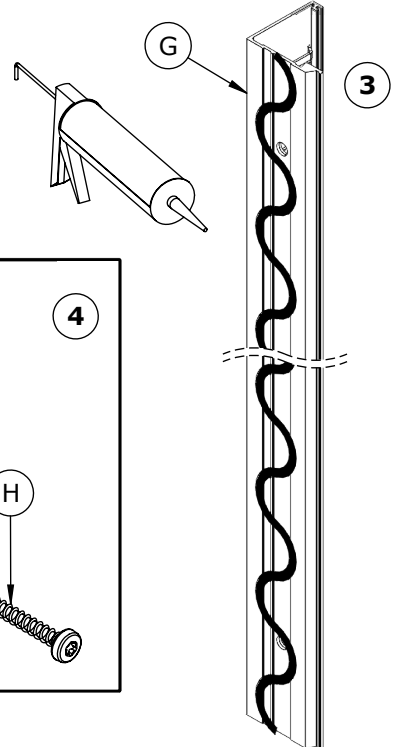
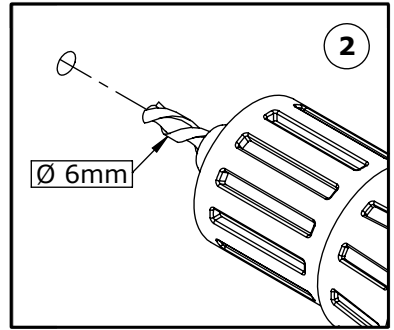
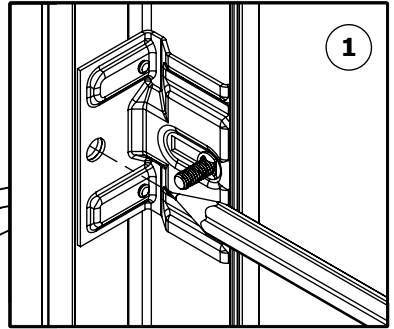
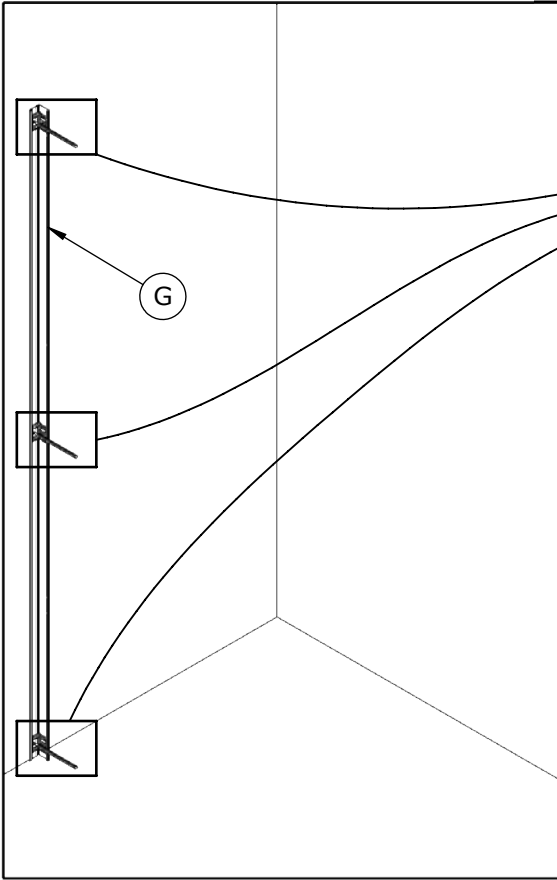

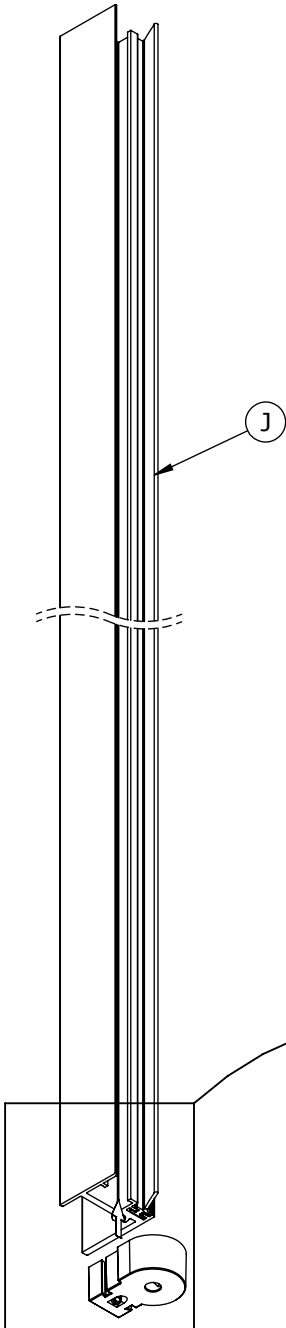

- Affleurant ● Flush
- Afloramiento ● Affioramento
- Doorspoelen ● Bündig

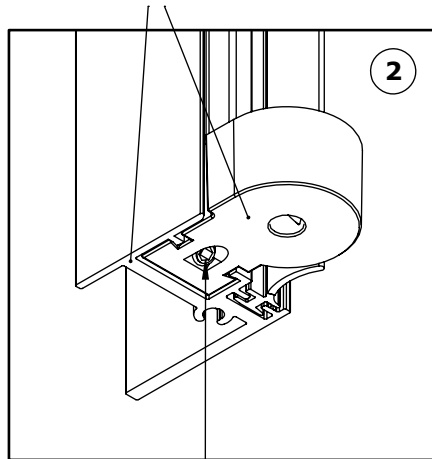

- Serrer fort ● Tighten hard
- Apretar fuerte ● Serrare forte
- Draai stevig vast ● Fest anziehen

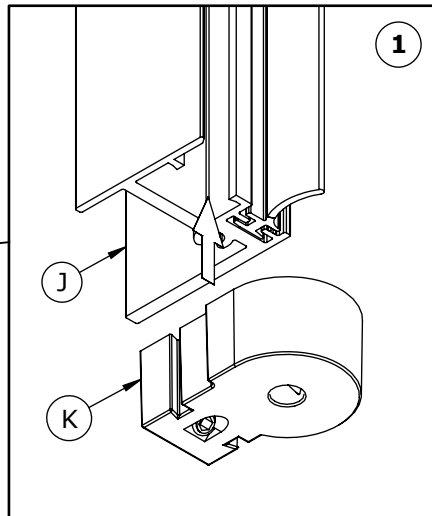

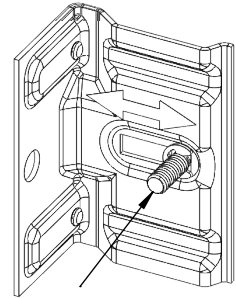
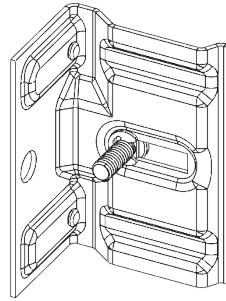

- Si nécessaire, desserrer, régler puis resserrer
- If necessary, loosen, adjust and retighten
- Si es necesario, afloje, ajuste y apriete
- Se necesario, allentare, regolare e stringere
- Draai los, indien nodig, stel af en draai vervolgens weer vast
- Falls erforderlich, lösen, einstellen und wieder festziehen

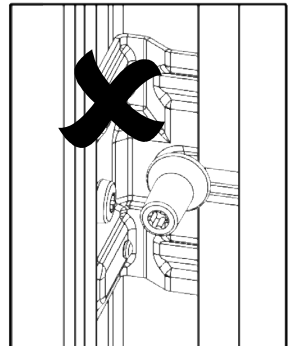
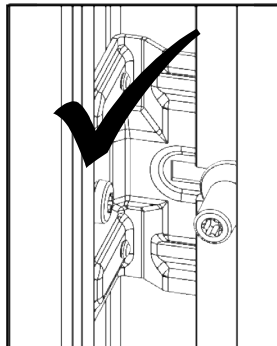
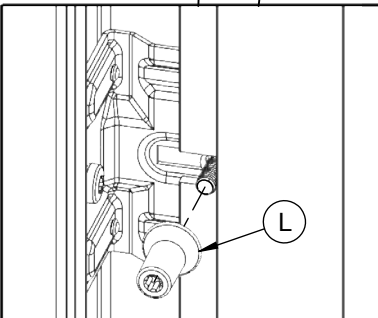
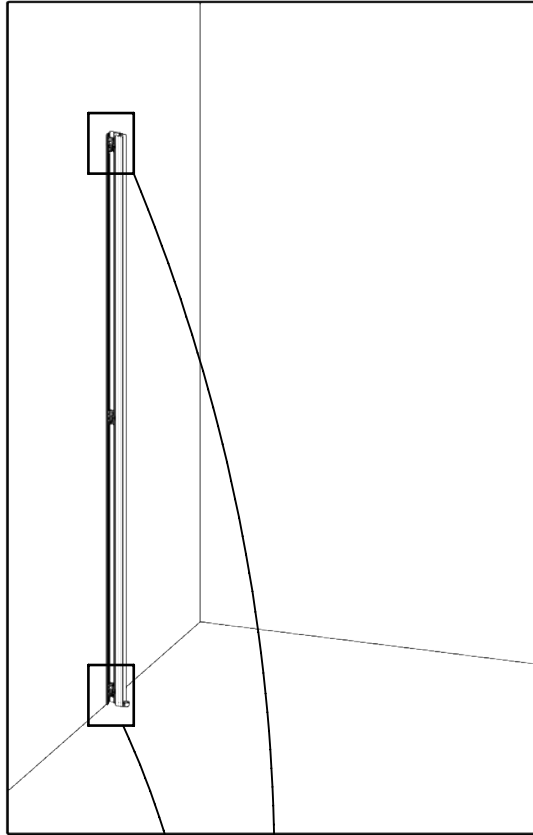

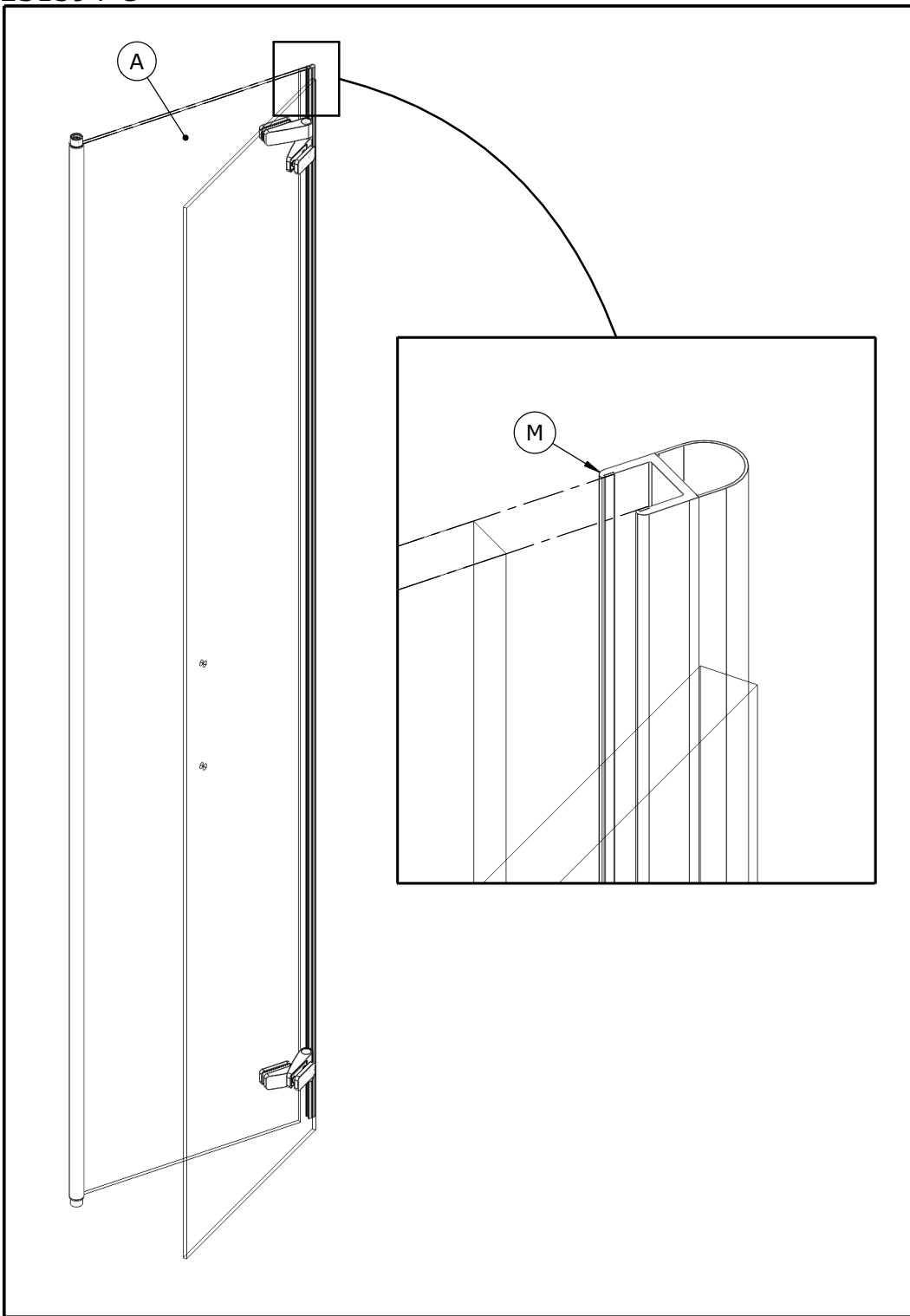

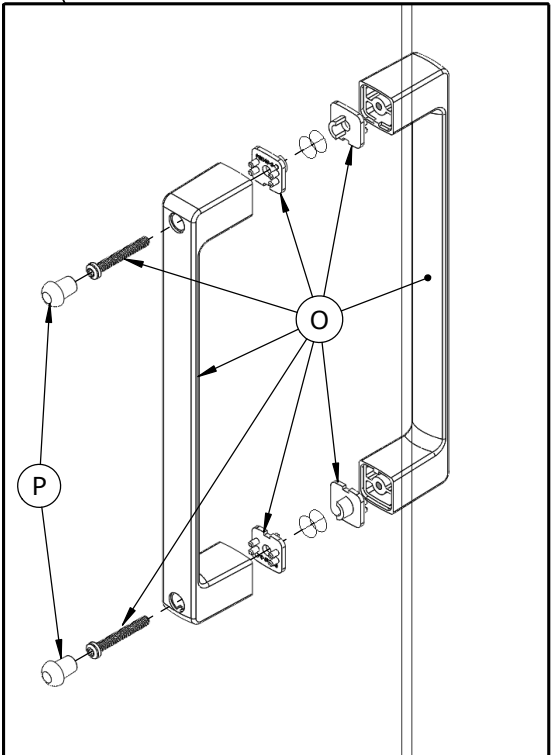
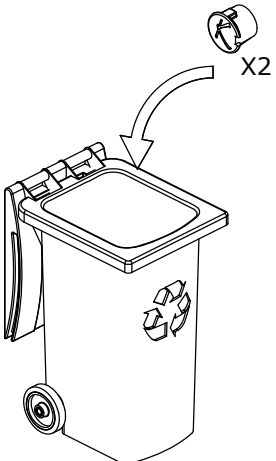
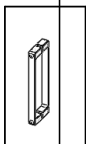
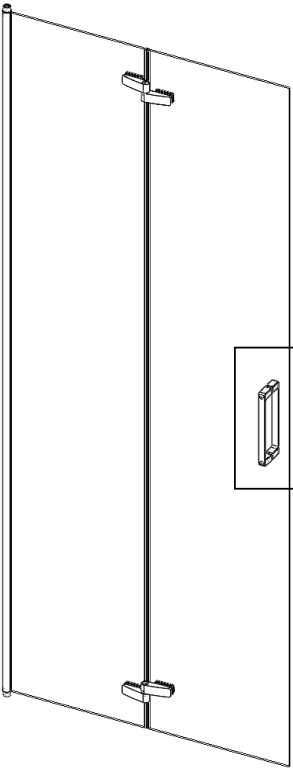

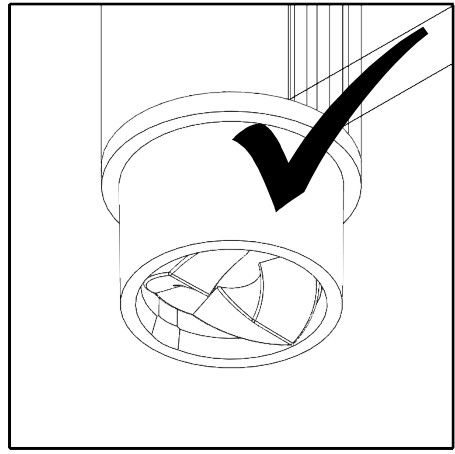
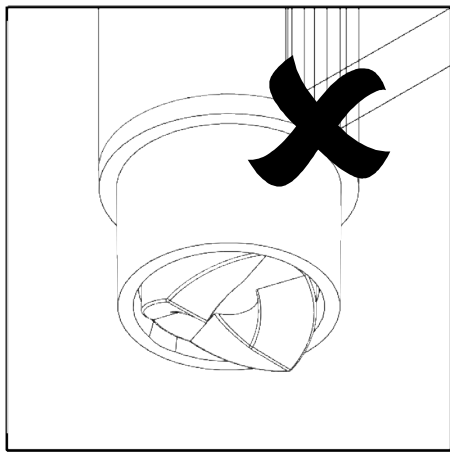
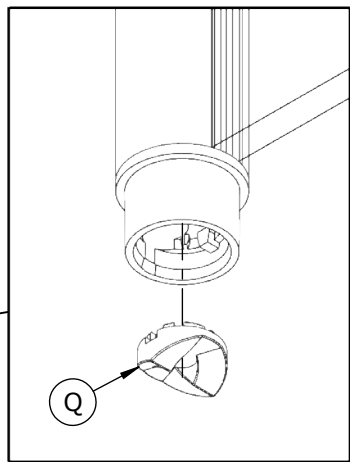
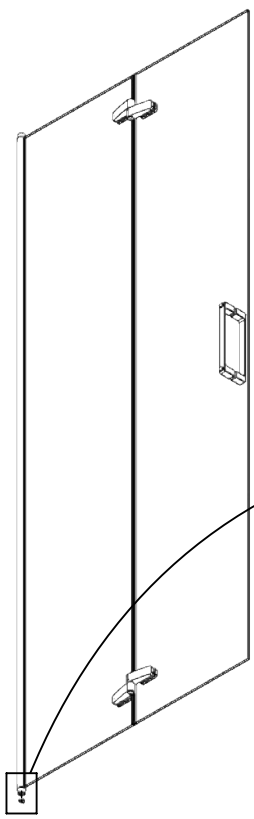

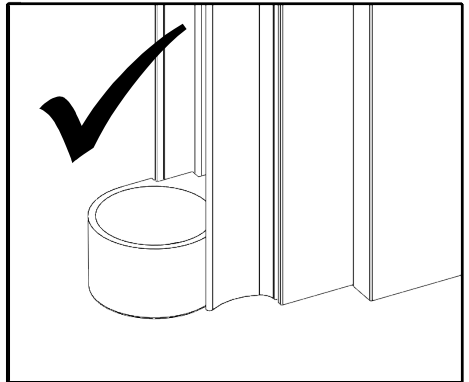
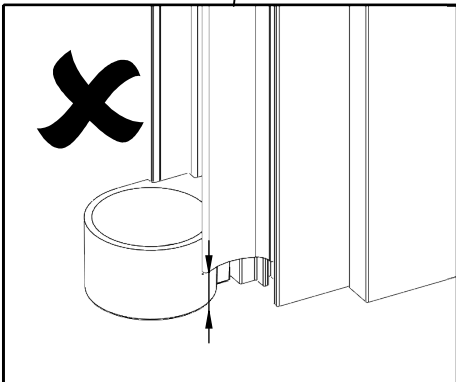
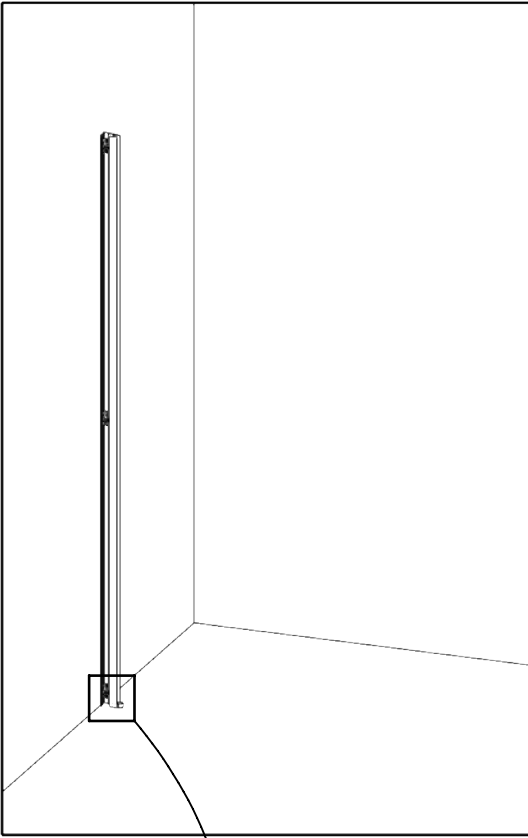

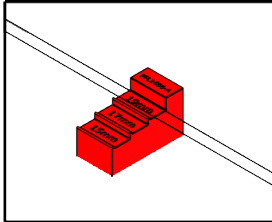
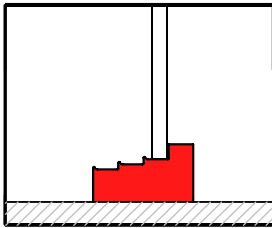
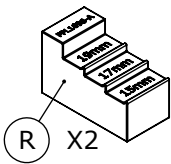
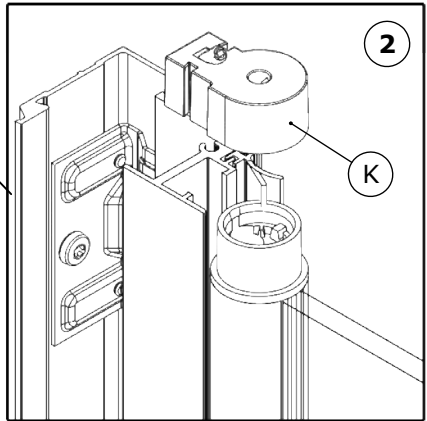
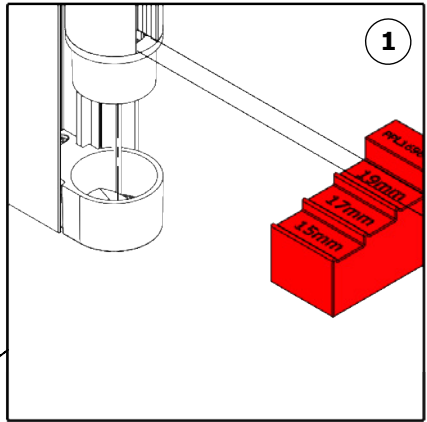
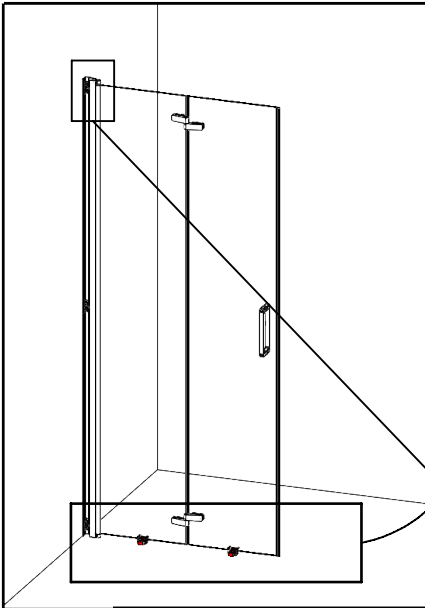

- Intérieur ● Inside
- Interior ● Interno
- Binnenkant ● Innen

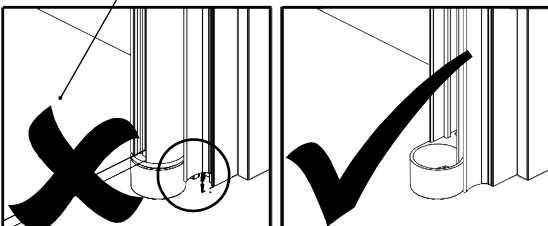

- Affleurant ● Flush
- Afloramiento ● Affioramento
- Doorspoelen ● Bündig

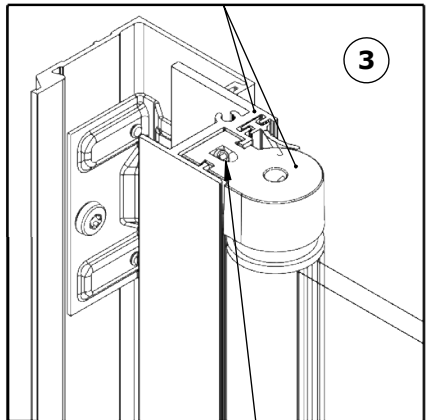

- Serrer ● Tighten
- Apriete ● Serrare
- Vastdraaien ● Festziehen

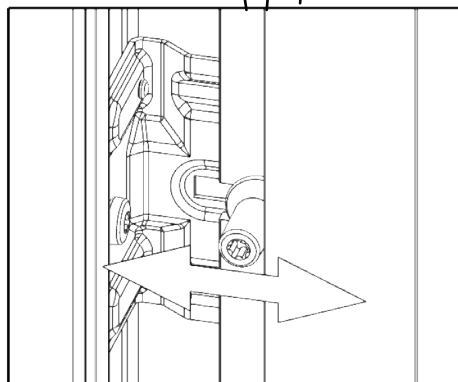
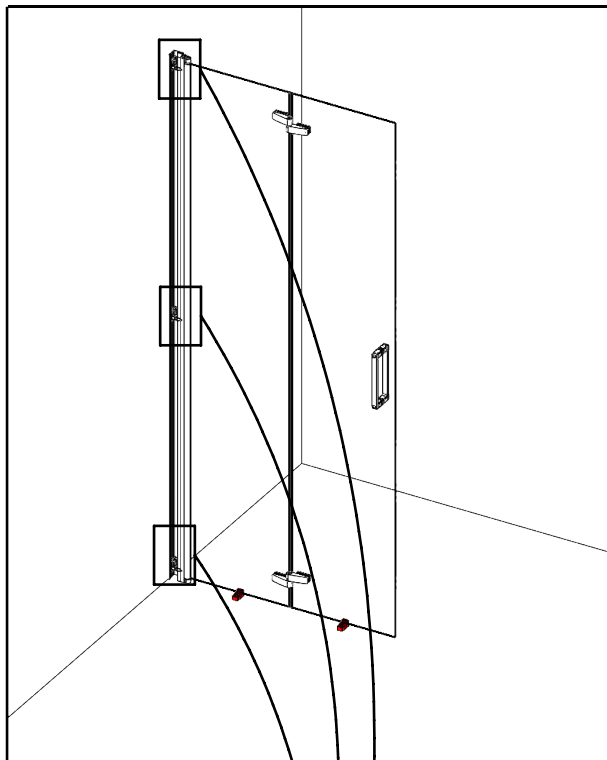

- **F** Si nécessaire, desserrer, régler puis resserrer
- **GB** If necessary, loosen, adjust and retighten
- **E** Si es necesario, afloje, ajuste y apriete
- **I** Se necessario, allentare, regolare e stringere
- **NL** Draai los, indien nodig, stel af en draai vervolgens weer vast
- **D** Falls erforderlich, lösen, einstellen und wieder festziehen

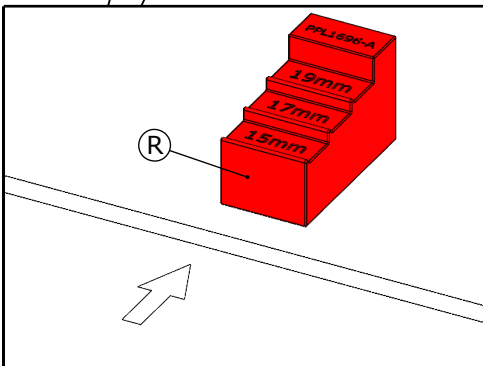
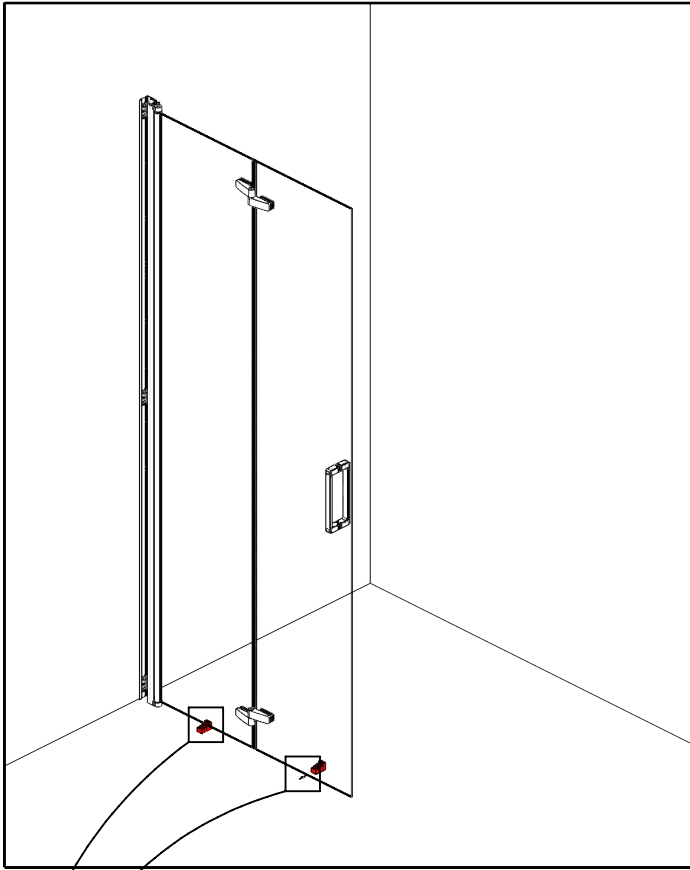

- Retirer (R) ● Remove (R) ● Togliere (R)
- Verwijderen (R) ● Entfernen (R)

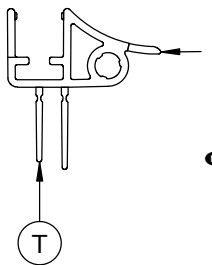
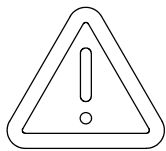

- Intérieur
- Ⓣ Inside
- Interior
- Interno
- Ⓣ Binnenkant
- Innen

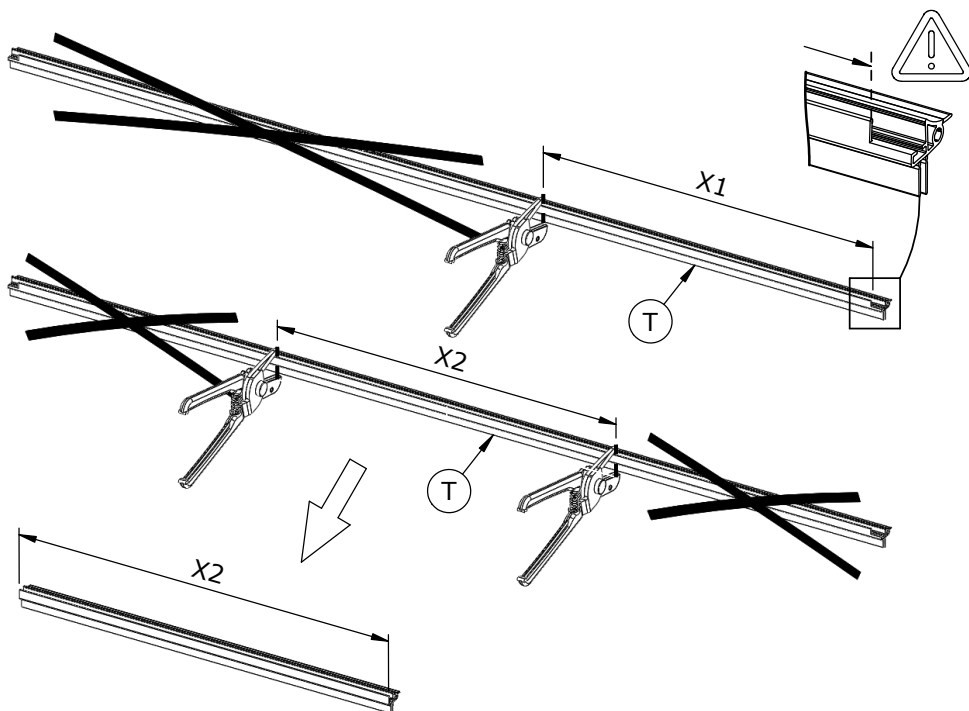
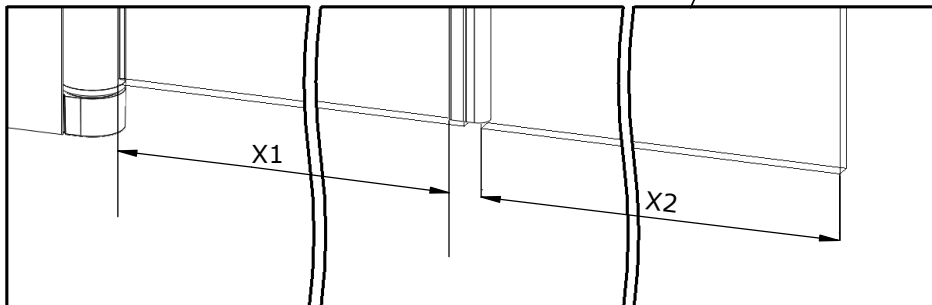
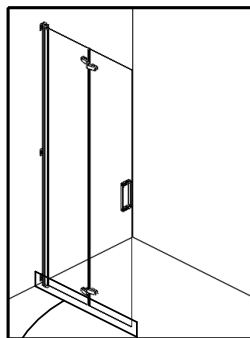

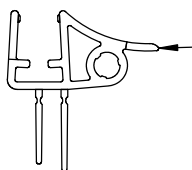

- F Intérieur
- GB Inside
- E Interior
- I Interno
- NL Binnenkant
- D Innen

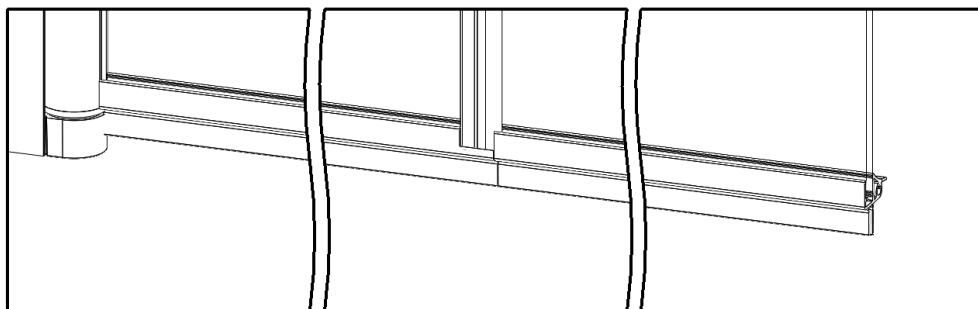
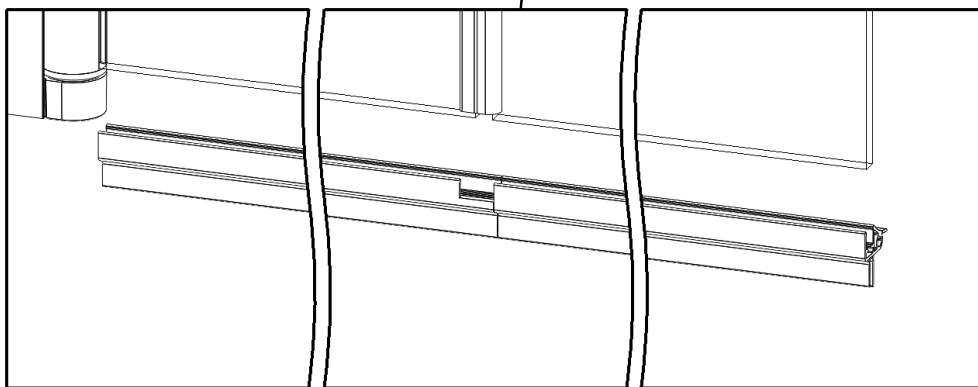
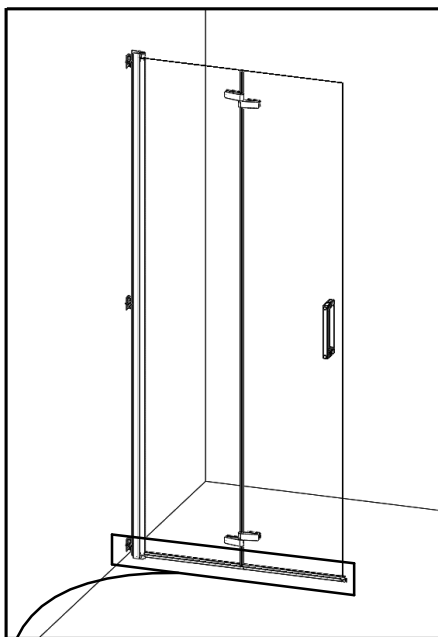

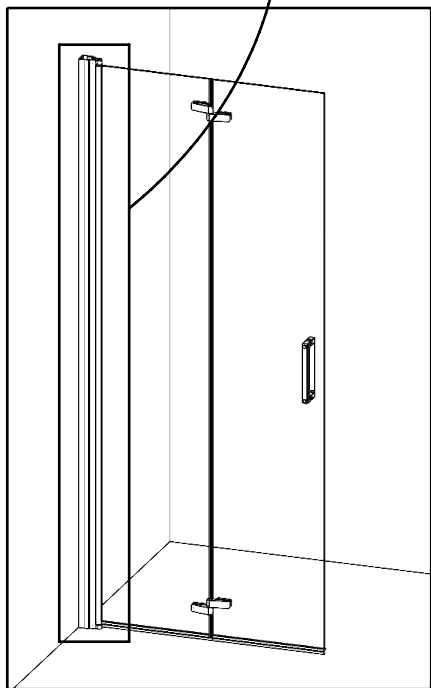
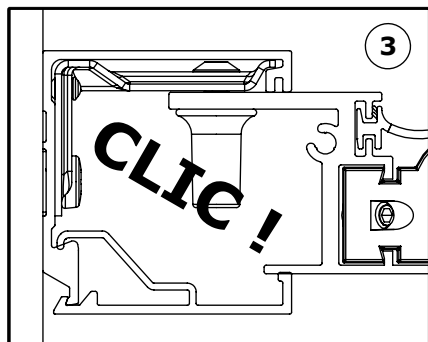
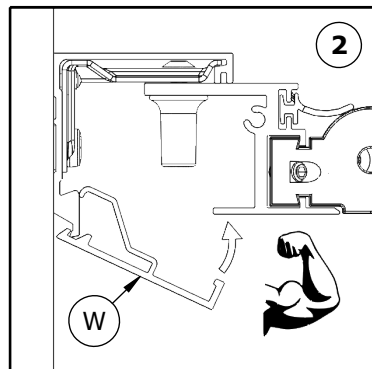
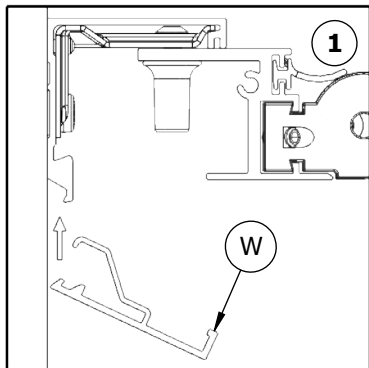

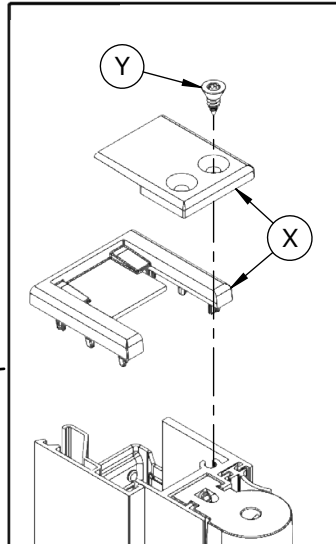
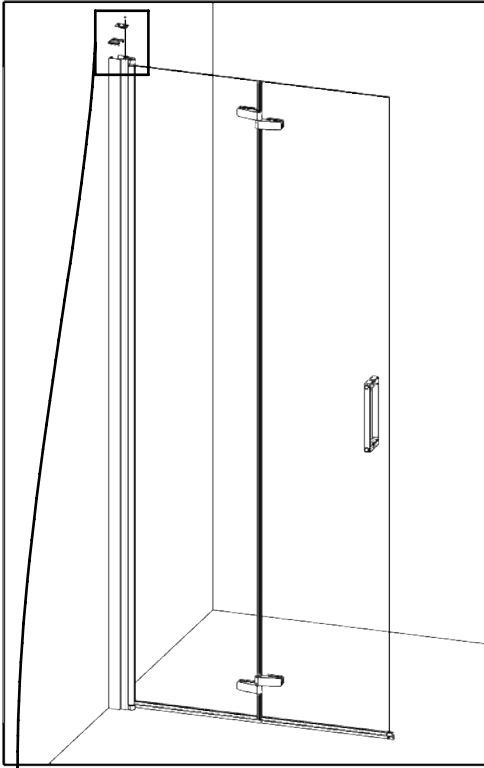



- Ⓕ Sens de montage
- Ⓖ Mounting direction
- Ⓔ Sentido de instalación
- Ⓛ Senso di montaggio
- Ⓜ Montagerichtung
- Ⓝ Montagerichtung

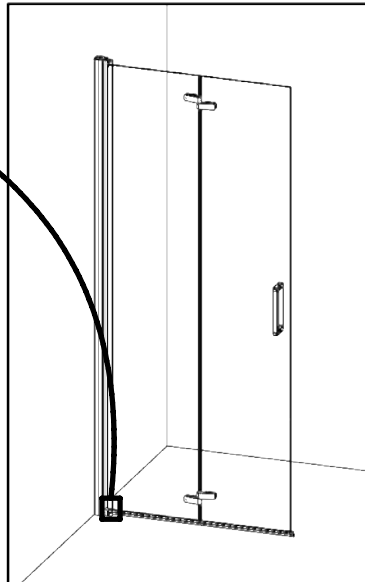
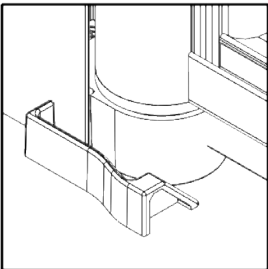
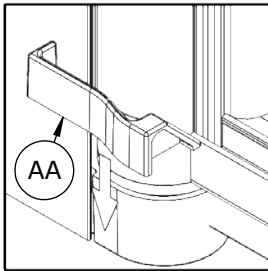
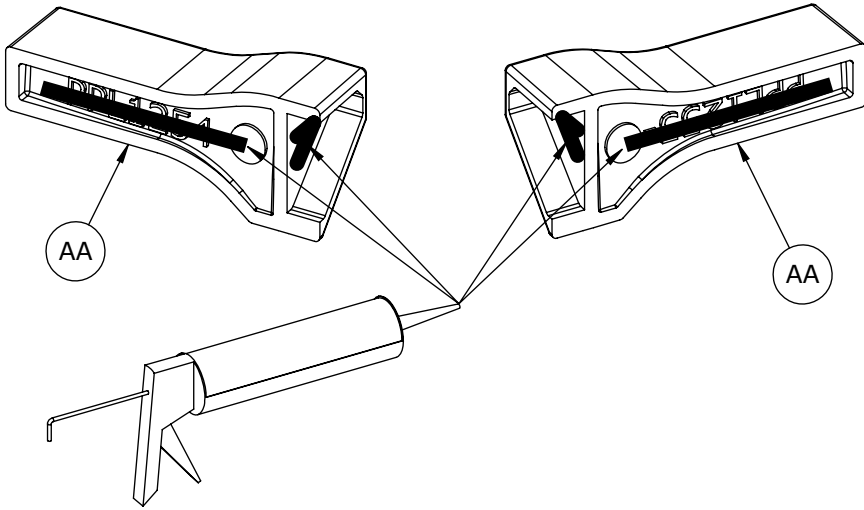

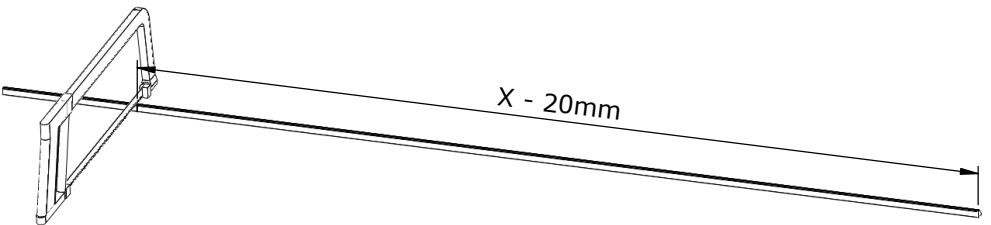
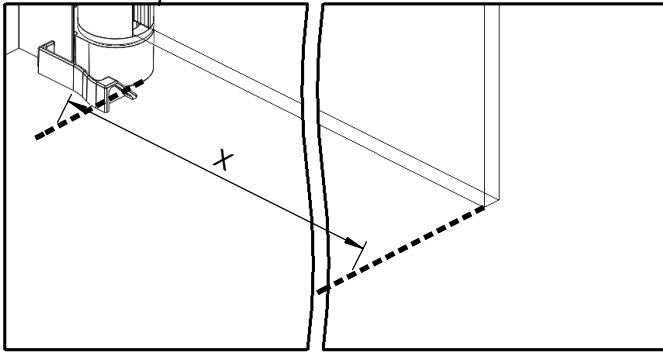
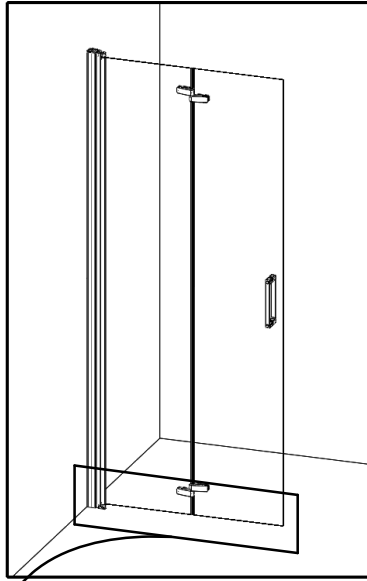

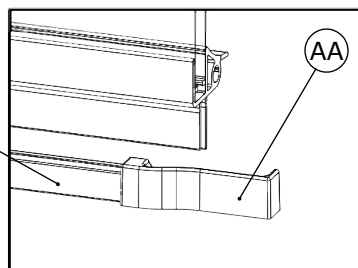
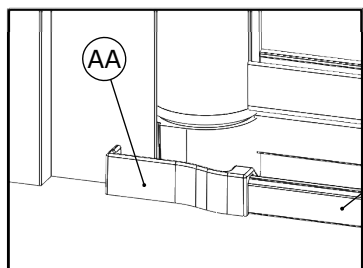
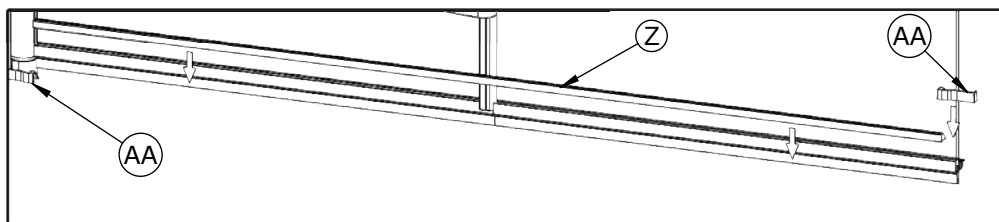
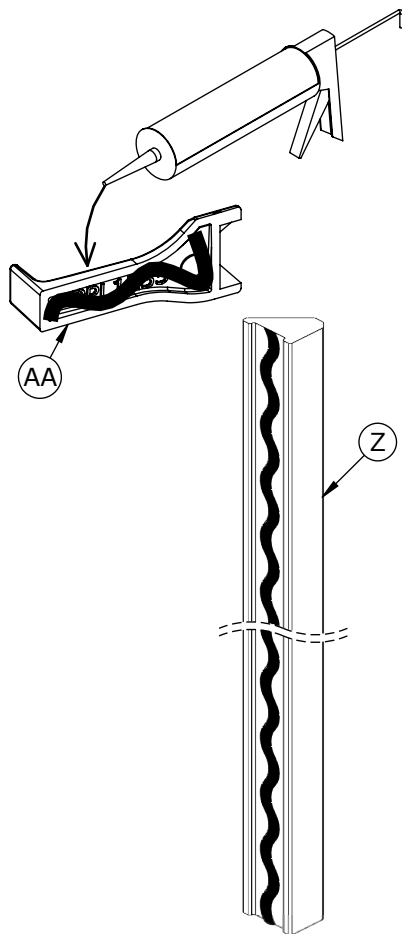
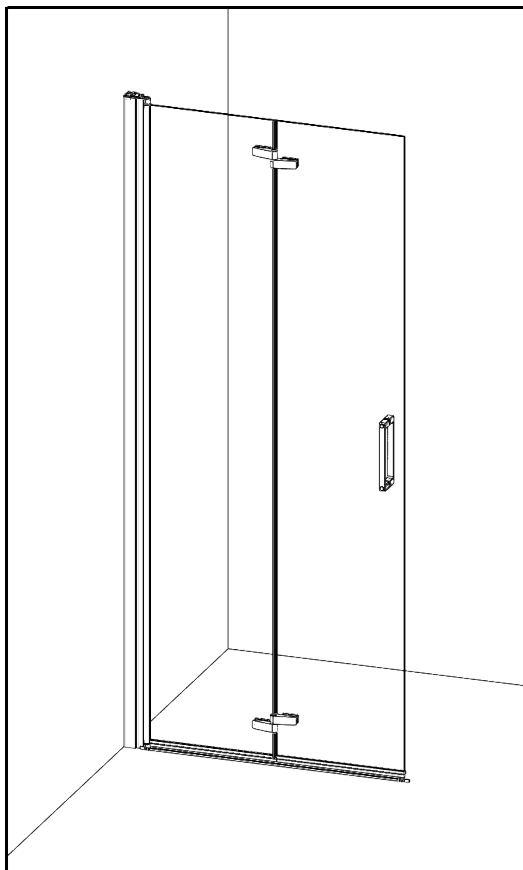

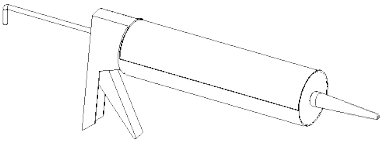



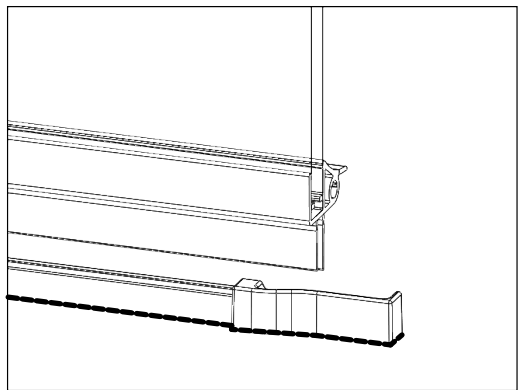
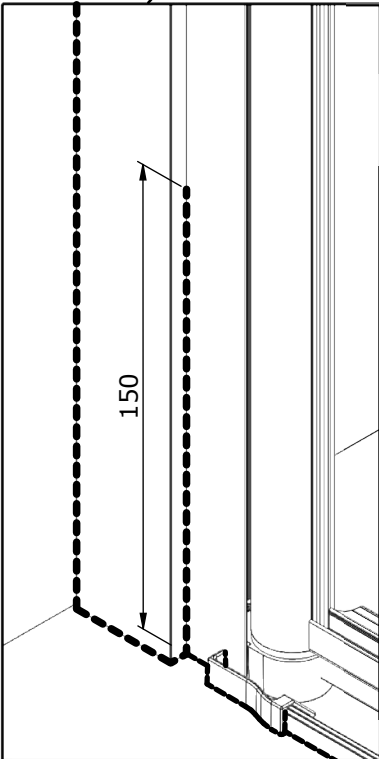
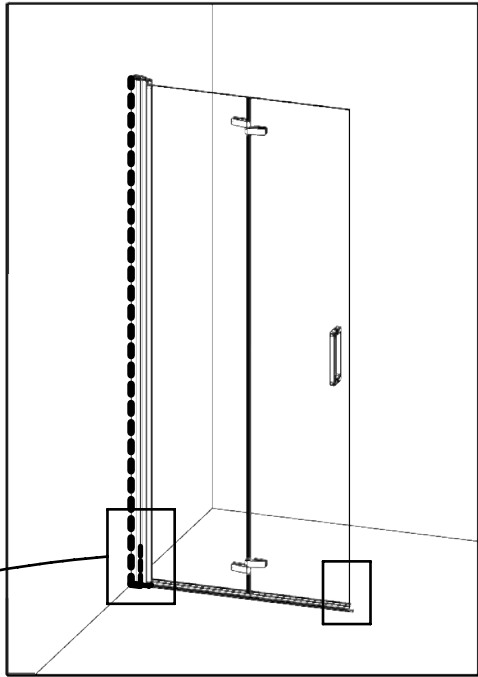





24H





<p>FR</p> <p>Bon de garantie</p> <p>SCANEZ MOI</p>  <p>http://tiny.cc/bon-de-garantie-fr</p>	<p>GB</p> <p>Guarantee</p> <p>SCAN ME</p>  <p>http://tiny.cc/bon-de-garantie-gb</p>
<p>DE</p> <p>Garantiekarte</p> <p>SCAN MICH</p>  <p>http://tiny.cc/bon-de-garantie-de</p>	<p>NL</p> <p>Garantievoorwaarden</p> <p>SCAN MIJ</p>  <p>http://tiny.cc/bon-de-garantie-nl</p>
<p>ES</p> <p>Garantía</p> <p>ESCANÉAME</p>  <p>http://tiny.cc/bon-de-garantie-es</p>	<p>IT</p> <p>Garanzia</p> <p>SCANSIONAMI</p>  <p>http://tiny.cc/bon-de-garantie-it</p>
<p>PT</p> <p>Garantia</p> <p>ESCANEEI-ME</p>  <p>http://tiny.cc/bon-de-garantie-pt</p>	<p>CH</p> <p>Garantiekarte</p> <p>SCAN MICH</p>  <p>http://tiny.cc/bon-de-garantie-ch</p>
<p>BE</p> <p>Garantievoorwaarden</p> <p>SCAN MIJ</p>  <p>http://tiny.cc/bon-de-garantie-be</p>	<p>AT</p> <p>Garantiekarte</p> <p>SCAN MICH</p>  <p>http://tiny.cc/bon-de-garantie-at</p>



Kinedo

<p>FR Conseils d'entretien</p> <p>SCANEZ MOI</p>  <p>http://tiny.cc/conseils-entretien-fr</p>	<p>GB Maintenance instructions</p> <p>SCAN ME</p>  <p>http://tiny.cc/conseils-entretien-gb</p>
<p>DE Wartungstipps</p> <p>SCAN MICH</p>  <p>http://tiny.cc/conseils-entretien-de</p>	<p>NL Onderhoudstips</p> <p>SCAN MIJ</p>  <p>http://tiny.cc/conseils-entretien-nl</p>
<p>ES Consejos de mantenimiento</p> <p>ESCANÉAME</p>  <p>http://tiny.cc/conseils-entretien-es</p>	<p>IT Consigli per la manutenzione</p> <p>SCANSIONAMI</p>  <p>http://tiny.cc/conseils-entretien-it</p>
<p>PT Dicas de manutenção</p> <p>ESCANEEI-ME</p>  <p>http://tiny.cc/conseils-entretien-pt</p>	<p>CH Wartungstipps</p> <p>SCAN MICH</p>  <p>http://tiny.cc/conseils-entretien-ch</p>
<p>BE Onderhoudstips</p> <p>SCAN MIJ</p>  <p>http://tiny.cc/conseils-entretien-be</p>	<p>AT Wartungstipps</p> <p>SCAN MICH</p>  <p>http://tiny.cc/conseils-entretien-at</p>

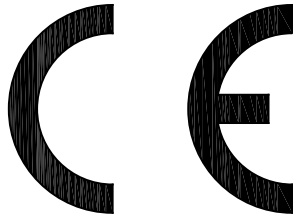

AQUAPRODUCTION, Site industriel,
F - 44680 Chaumes-en-Retz

18

EN 14428

Paroi de douche, fabriquée en verre de silicate
sodo-calcique de sécurité trempé thermiquement

Aptitude au nettoyage : réussite

Résistance à l'impact/propriétés de fragmentation : réussite

Durabilité : réussite



SERVICE APRÈS-VENTE AFTER-SALES SERVICE

FRANCE

+33 (0)2 40 21 29 45

UK

+44 (0)20 8842 0033

IRELAND

+353 04697 33102

DEUTSCHLAND

+49 (0) 6074 / 30928 0

ITALIA

+39 02 30559420

ÖSTEREICH

+43 1 710 60 70

SUISSE/SCHWEIZ

+41 (0)32 631 04 74

ESPAÑA

+34 93 544 60 76

NEDERLAND

+31 475 487 100

BELGIQUE/BELGIË

+31 475 487 100

РОССИЯ

+7 495 258-29-51

PORTUGAL

+351 219 112 785