

Notre service technique est à votre écoute aux numéros qui sont au dos de cette notice d'installation

GIR1208ND-F

Ⓐ Position de la cabine Ⓑ Position of the shower cubicle  
 Ⓒ Posición de la cabina de ducha Ⓓ Posizione della cabina doccia  
 Ⓔ Positie van de douchecabine Ⓕ Position der Duschkabine

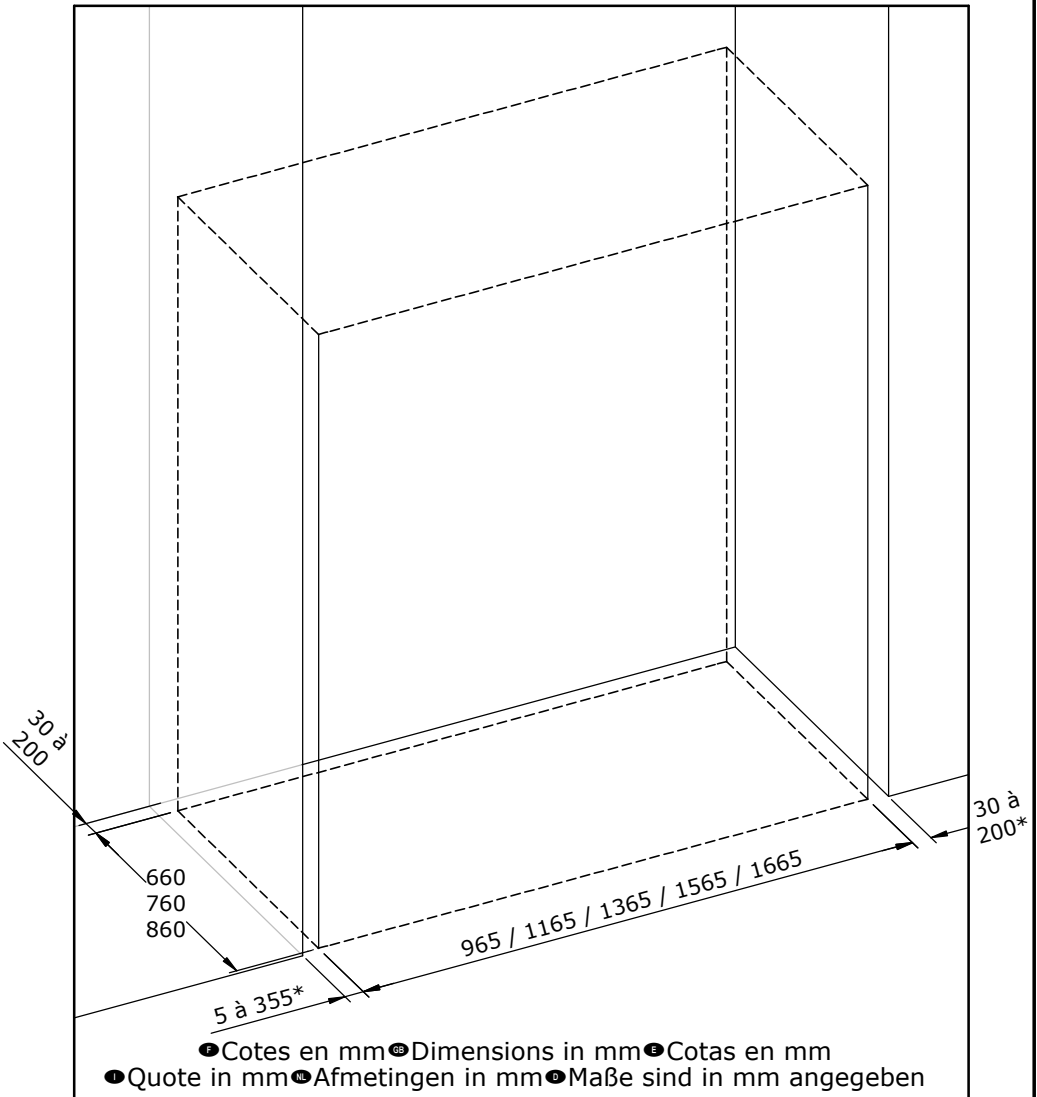

\* Ⓐ Côté gauche et droit cumulés ne peuvent excéder 385 mm.

Ⓑ Left and right sides summed must not exceed 385 mm.

Ⓒ Las cuotas agregadas izquierda y derecha no pueden superar 385 mm.

Ⓓ Sinistra e destra combinati non possono superare 385 mm.

Ⓔ De linker- en rechterzijde mogen samen niet groter zijn dan 385 mm.

Ⓕ Links und rechts dürfen es zusammen nicht mehr als 385 mm sein.



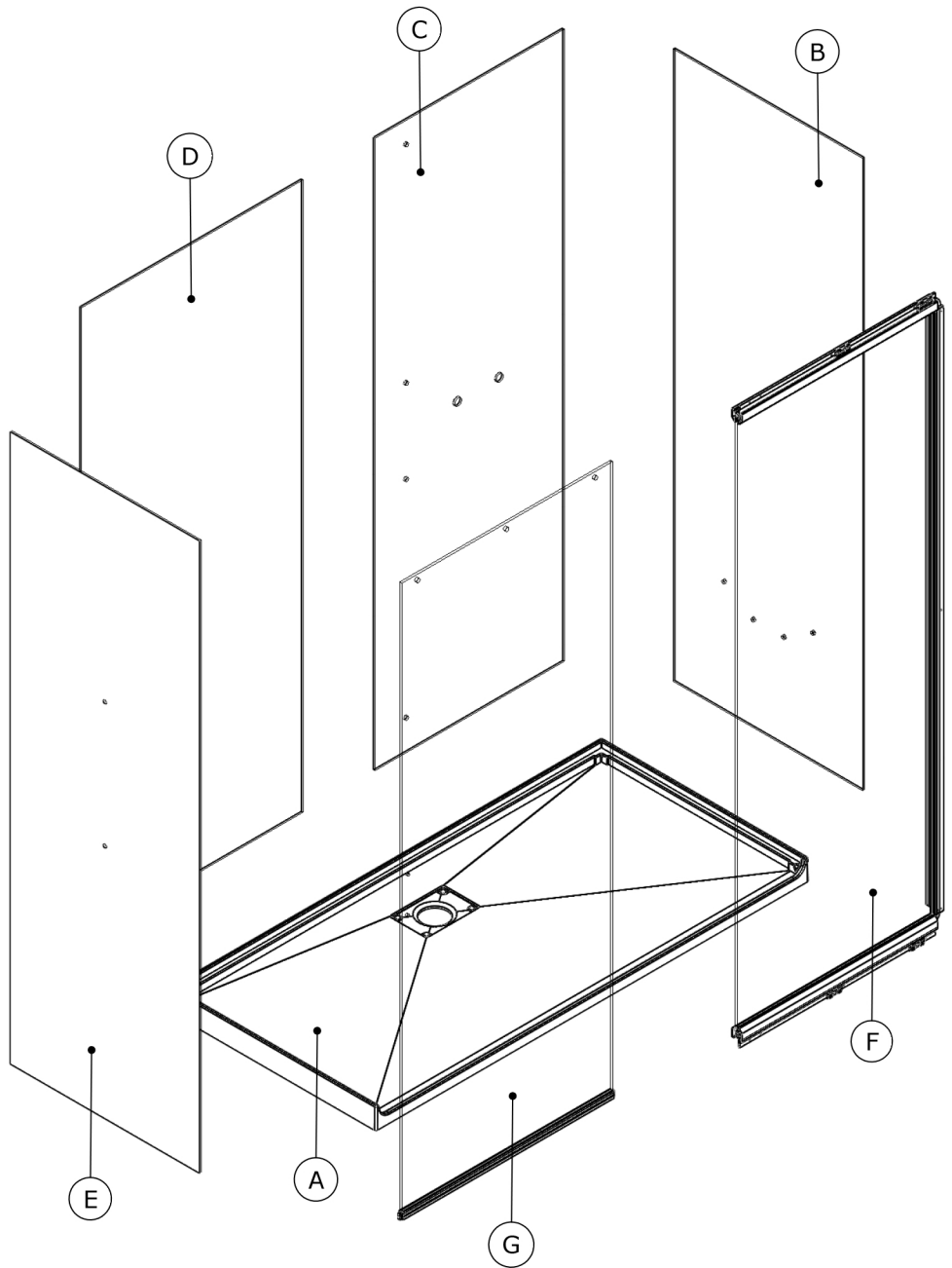

- CODE COLIS (Voir repères en page 4)
- PACKAGE CODES (See marks on page 4)
- REF. BULTOS (Ver pg. 4 para listado de bultos)
- CODE SET (zie blz. 4)
- Codering verpakking (zie omschrijving op pagina 4)
- PAKETCODES (siehe Kennzeichnungen auf Seite 4)

REP	VERSION	100 x 70	100 x 80	100 x 90	120 x 70	120 x 80	120 x 90	140 x 70	140 x 80	140 x 90	160 x 70	160 x 80	160 x 90	170 x 70	170 x 80	170 x 90
A		RECS61	RECS62	RECS63	RECS64	RECS65	RECS66	RECS67	RECS68	RECS69	RECS70	RECS71	RECS72	RECS73	RECS74	RECS75
B		C11444E	C11445E	C11446E	C11444E	C11445E	C11446E	C11444E	C11445E	C11446E	C11444E	C11445E	C11446E	C11444E	C11445E	C11446E
C		C11439E			C11431E											
D					C11440E			C11441E			C11442E			C11443E		
E		C11354E	C11355E	C11356E	C11354E	C11355E	C11356E	C11354E	C11355E	C11356E	C11354E	C11355E	C11356E	C11354E	C11355E	C11356E
F	SER	C11374E			C11375E			C11376E			C11377E			C11378E		
	TN	C11369E			C11370E			C11371E			C11372E			C11373E		
G	SER	C11394E			C11395E			C11396E			C11397E			C11398E		
	TN	C11389E			C11390E			C11391E			C11392E			C11393E		

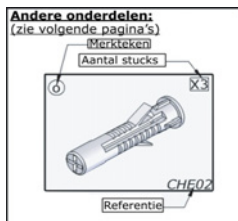
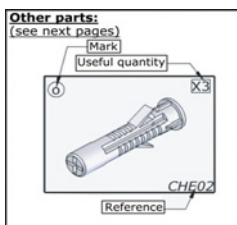
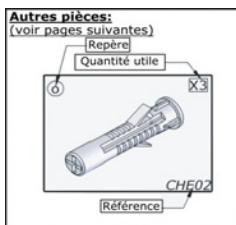

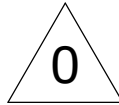

<p><b>SK</b></p> <ul style="list-style-type: none"> <li>● Montage gauche ● Left hand</li> <li>● Montaje a la izquierda</li> <li>● Montaggio a sinistra</li> <li>● Montage links ● Montage links</li> </ul> <p><b>SUP172</b> x1</p>	<p><b>SL</b></p> <ul style="list-style-type: none"> <li>● Montage droite ● Right hand</li> <li>● Montaje a la derecha</li> <li>● Montaggio a destra</li> <li>● Montage rechts ● Montage rechts</li> </ul> <p><b>SUP173</b> x1</p>	<p><b>PS</b></p> <p><b>PPL1116</b> x2</p>
<p><b>SC</b></p> <ul style="list-style-type: none"> <li>● Montage gauche ● Left hand</li> <li>● Montaje a la izquierda</li> <li>● Montaggio a sinistra</li> <li>● Montage links ● Montage links</li> </ul> <p><b>SUP164</b> x1</p>	<p><b>SD</b></p> <ul style="list-style-type: none"> <li>● Montage droite ● Right hand</li> <li>● Montaje a la derecha</li> <li>● Montaggio a destra</li> <li>● Montage rechts ● Montage rechts</li> </ul> <p><b>SUP165</b> x1</p>	<p><b>PT</b> 120/140/160/170 x1 100 x0</p> <p><b>PPL1117</b></p>
<p><b>PG</b></p> <ul style="list-style-type: none"> <li>● Montage gauche ● Left hand</li> <li>● Montaje a la izquierda</li> <li>● Montaggio a sinistra</li> <li>● Montage links ● Montage links</li> </ul> <p><b>PPL1102</b> x1</p>	<p><b>PH</b></p> <ul style="list-style-type: none"> <li>● Montage droite ● Right hand</li> <li>● Montaje a la derecha</li> <li>● Montaggio a destra</li> <li>● Montage rechts ● Montage rechts</li> </ul> <p><b>PPL1103</b> x1</p>	<p><b>MA</b></p> <p><b>MIT100</b> x1</p>
<p><b>PAB</b></p> <ul style="list-style-type: none"> <li>● Montage gauche ● Left hand</li> <li>● Montaje a la izquierda</li> <li>● Montaggio a sinistra</li> <li>● Montage links ● Montage links</li> </ul> <p><b>PPL1134</b> x1</p>	<p><b>PAC</b></p> <ul style="list-style-type: none"> <li>● Montage droite ● Right hand</li> <li>● Montaje a la derecha</li> <li>● Montaggio a destra</li> <li>● Montage rechts ● Montage rechts</li> </ul> <p><b>PPL1135</b> x1</p>	<p><b>MB</b></p> <p><b>MIT94</b> x1</p>
<p><b>PAX</b></p> <p><b>PPL1318</b> x4</p>	<p><b>VG</b></p> <p><b>SET03</b> x2</p>	<p><b>MIT94</b></p>

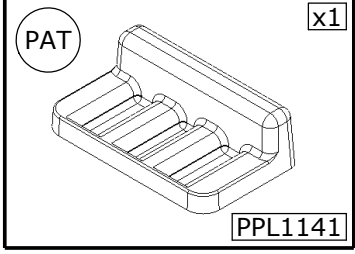
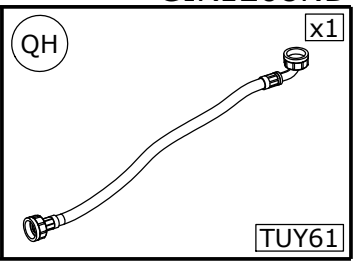
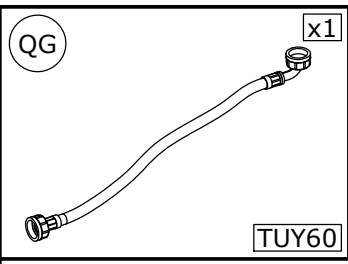
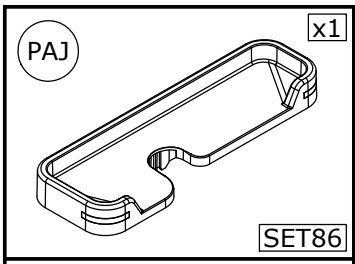

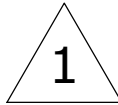

<p>PA 120/140/160/170 x11 100 x9</p> <p>PPL802</p>	<p>PB 120/140/160/170 x11 100 x9</p> <p>PPL804</p>	<p>QA x1</p> <p>BOND28</p>													
<p>TA x1</p> <p>TOL11</p>	<p>VN Ø4 x11</p> <p>45</p> <p>1=1 VIS231</p>														
<p>VA x11</p> <p>CHE02</p>	<p>VV x11</p> <p>RON34</p>	<p>AU x2</p> <p>Lg=1940mm 6210-01</p>													
<p>AA x1</p> <p>Lg=1972mm 6189-01</p>	<p>AS x1</p> <table border="1"> <thead> <tr> <th colspan="2">6209</th> </tr> <tr> <th>● Longueur ● Length ● Largo</th> <th>● Lunghezza ● Lengte ● Länge</th> </tr> </thead> <tbody> <tr> <td>100</td> <td>Lg=950mm</td> </tr> <tr> <td>120</td> <td>Lg=1150mm</td> </tr> <tr> <td>140</td> <td>Lg=1350mm</td> </tr> <tr> <td>160</td> <td>Lg=1550mm</td> </tr> <tr> <td>170</td> <td>Lg=1650mm</td> </tr> </tbody> </table>	6209		● Longueur ● Length ● Largo	● Lunghezza ● Lengte ● Länge	100	Lg=950mm	120	Lg=1150mm	140	Lg=1350mm	160	Lg=1550mm	170	Lg=1650mm
6209															
● Longueur ● Length ● Largo	● Lunghezza ● Lengte ● Länge														
100	Lg=950mm														
120	Lg=1150mm														
140	Lg=1350mm														
160	Lg=1550mm														
170	Lg=1650mm														
<p>AB 120/140/160/170 x1 100 x0</p> <p>Lg=1972mm 6190-01</p>	<p>AT x1</p> <table border="1"> <thead> <tr> <th colspan="2">6209</th> </tr> <tr> <th>● Largeur ● Width ● Ancho</th> <th>● Larghezza ● Breedte ● Breite</th> </tr> </thead> <tbody> <tr> <td>70</td> <td>Lg=635mm</td> </tr> <tr> <td>80</td> <td>Lg=735mm</td> </tr> <tr> <td>90</td> <td>Lg=835mm</td> </tr> </tbody> </table>	6209		● Largeur ● Width ● Ancho	● Larghezza ● Breedte ● Breite	70	Lg=635mm	80	Lg=735mm	90	Lg=835mm				
6209															
● Largeur ● Width ● Ancho	● Larghezza ● Breedte ● Breite														
70	Lg=635mm														
80	Lg=735mm														
90	Lg=835mm														

2

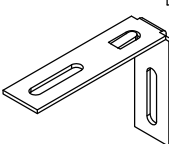
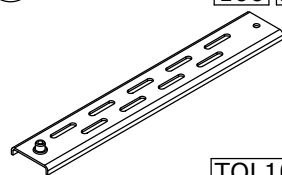
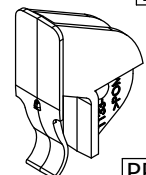
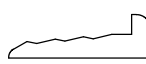
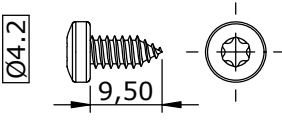
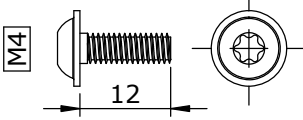
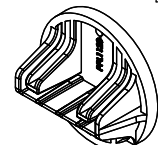
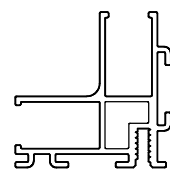
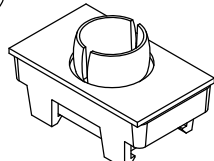
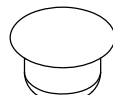
<p>TE <math>\frac{120/140/160/170}{100} \frac{x6}{x4}</math></p>  <p>TOL102</p>	<p>TF <math>\frac{120/140/160/170}{100} \frac{x6}{x4}</math></p>  <p>TOL103</p>	<p>PAA <math>\frac{120/140/160/170}{100} \frac{x5}{x4}</math></p>  <p>PPL1133</p>
<p>JG <math>\frac{120/140/160/170}{100} \frac{x6}{x4}</math></p>  <p>Lg=1971mm</p> <p>P101</p>	<p>VQ <math>\frac{120/140/160/170}{100} \frac{x5}{x4}</math></p>  <p>Ø4.2 9,50</p> <p>1=1 VIS238</p>	<p>VR <math>\frac{120/140/160/170}{100} \frac{x6}{x4}</math></p>  <p>M4 12</p> <p>1=1 VIS239</p>
<p>PAL <math>\frac{120/140/160/170}{100} \frac{x1}{x0}</math></p>  <p>PPL1128</p>	<p>AA <math>\frac{120/140/160/170}{100} \frac{x1}{x0}</math></p>  <p>Lg=1972mm</p> <p>6189-01</p>	<p>VD <math>\frac{120/140/160/170}{100} \frac{x1}{x0}</math></p>  <p>SET88</p>
<p>QB <math>\frac{120/140/160/170}{100} \frac{x2}{x3}</math></p>  <p>BOU40</p>		

3

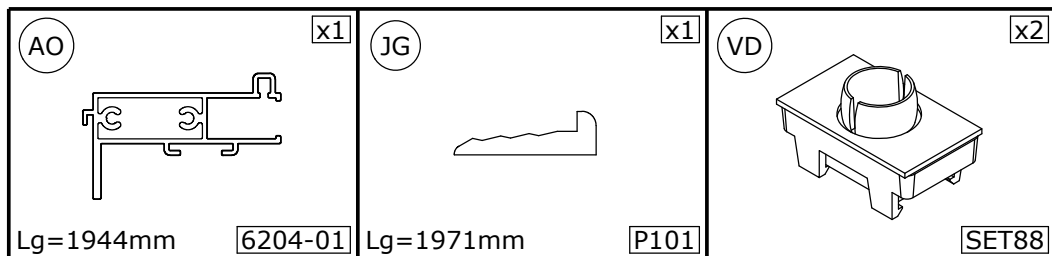

4

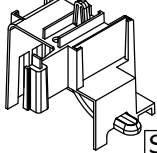
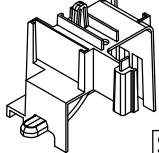
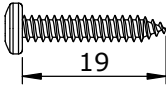
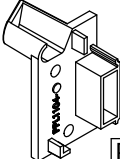
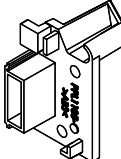
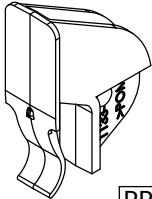
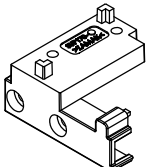
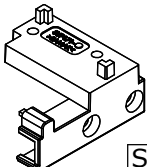
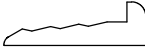
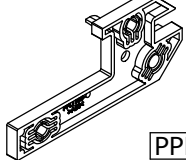
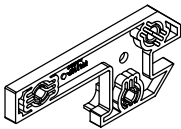
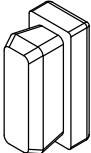
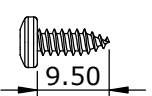
<p><b>SA</b></p> <ul style="list-style-type: none"> <li>● Montage gauche ● Left hand</li> <li>● Montaje a la izquierda</li> <li>● Montaggio a sinistra</li> <li>● Montage links ● Montage links</li> </ul>  <p><b>SET107</b></p> <p><b>x1</b></p>	<p><b>SB</b></p> <ul style="list-style-type: none"> <li>● Montage droite ● Right hand</li> <li>● Montaje a la derecha</li> <li>● Montaggio a destra</li> <li>● Montage rechts ● Montage rechts</li> </ul>  <p><b>SET108</b></p> <p><b>x1</b></p>	<p><b>VM</b></p> <p><math>\varnothing 3.5</math></p>  <p>19</p> <p><b>1=1</b></p> <p><b>VIS215</b></p> <p><b>x8</b></p>
<p><b>PI</b></p> <ul style="list-style-type: none"> <li>● Montage gauche ● Left hand</li> <li>● Montaje a la izquierda</li> <li>● Montaggio a sinistra</li> <li>● Montage links ● Montage links</li> </ul>  <p><b>PPL1104</b></p> <p><b>x1</b></p>	<p><b>PJ</b></p> <ul style="list-style-type: none"> <li>● Montage droite ● Right hand</li> <li>● Montaje a la derecha</li> <li>● Montaggio a destra</li> <li>● Montage rechts ● Montage rechts</li> </ul>  <p><b>PPL1105</b></p> <p><b>x1</b></p>	<p><b>PAA</b></p>  <p><b>PPL1133</b></p> <p><b>x1</b></p>
<p><b>SI</b></p> <ul style="list-style-type: none"> <li>● Montage gauche ● Left hand</li> <li>● Montaje a la izquierda</li> <li>● Montaggio a sinistra</li> <li>● Montage links ● Montage links</li> </ul>  <p><b>SUP170</b></p> <p><b>x1</b></p>	<p><b>SJ</b></p> <ul style="list-style-type: none"> <li>● Montage droite ● Right hand</li> <li>● Montaje a la derecha</li> <li>● Montaggio a destra</li> <li>● Montage rechts ● Montage rechts</li> </ul>  <p><b>SUP171</b></p> <p><b>x1</b></p>	<p><b>JG</b></p>  <p><b>Lg=1971mm</b></p> <p><b>P101</b></p> <p><b>x1</b></p>
<p><b>PK</b></p> <ul style="list-style-type: none"> <li>● Montage gauche ● Left hand</li> <li>● Montaje a la izquierda</li> <li>● Montaggio a sinistra</li> <li>● Montage links ● Montage links</li> </ul>  <p><b>PPL1106</b></p> <p><b>x1</b></p>	<p><b>PL</b></p> <ul style="list-style-type: none"> <li>● Montage droite ● Right hand</li> <li>● Montaje a la derecha</li> <li>● Montaggio a destra</li> <li>● Montage rechts ● Montage rechts</li> </ul>  <p><b>PPL1107</b></p> <p><b>x1</b></p>	<p><b>QC</b></p>  <p><b>BUT22</b></p> <p><b>x1</b></p>
<p><b>VP</b></p> <p><math>\varnothing 3.5</math></p>  <p>9.50</p> <p><b>1=1</b></p> <p><b>VIS237</b></p> <p><b>x3</b></p>		

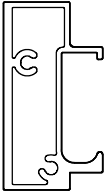
**AG**  x1

6196		
● Longueur	● Length	● Largo
● Lunghezza	● Lengte	● Länge
100		Lg=880mm
120		Lg=1080mm
140		Lg=1280mm
160		Lg=1480mm
170		Lg=1580mm

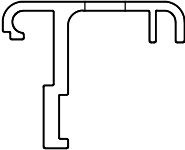
**AD**  x1

6194		
● Longueur	● Length	● Largo
● Lunghezza	● Lengte	● Länge
100		Lg=456mm
120		Lg=556mm
140		Lg=656mm
160		Lg=756mm
170		Lg=806mm

**AJ**  x1

6199		
● Longueur	● Length	● Largo
● Lunghezza	● Lengte	● Länge
100		Lg=401mm
120		Lg=501mm
140		Lg=601mm
160		Lg=701mm
170		Lg=751mm

**AQ** x2



Lg=300mm 6206-01

5

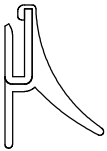
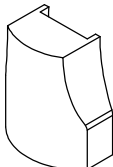
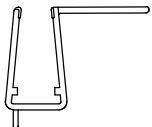
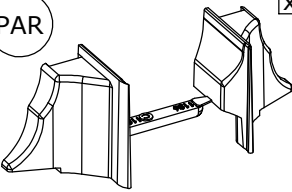
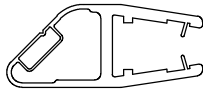
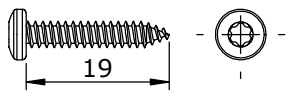
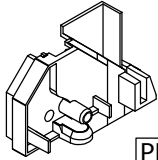
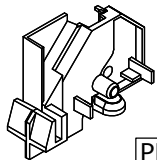
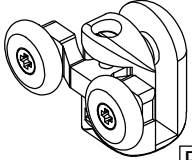
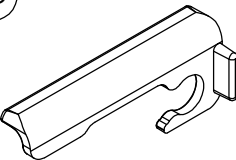
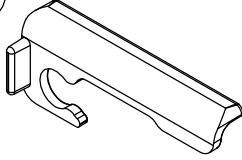
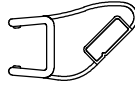
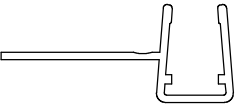
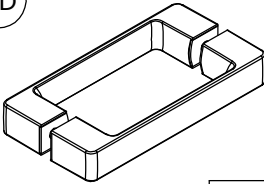
<p>JE <span style="float: right;">x1</span></p>  <p>Lg=820mm <span style="float: right;">JOI239</span></p>	<p>PC <span style="float: right;">x1</span></p>  <p><span style="float: right;">PPL823</span></p>	<p>JC <span style="float: right;">x1</span></p>  <p>Lg=1882mm <span style="float: right;">J723</span></p>
<p>PAR <span style="float: right;">x1</span></p>  <p><span style="float: right;">PPL1136/1137</span></p>	<p>JB <span style="float: right;">x1</span></p>  <p>Lg=1959mm <span style="float: right;">AI150</span></p>	<p>VM <span style="float: right;">Ø3.5</span> <span style="float: right;">x1</span></p>  <p><span style="float: right;">1=1</span> <span style="float: right;">VIS215</span></p>
<p>PO <span style="float: right;">x1</span></p> <ul style="list-style-type: none"> <li>● Montage gauche ● Left hand</li> <li>● Montaje a la izquierda</li> <li>● Montaggio a sinistra</li> <li>● Montage links ● Montage links</li> </ul>  <p><span style="float: right;">PPL1110</span></p>	<p>PP <span style="float: right;">x1</span></p> <ul style="list-style-type: none"> <li>● Montage droite ● Right hand</li> <li>● Montaje a la derecha</li> <li>● Montaggio a destra</li> <li>● Montage rechts ● Montage rechts</li> </ul>  <p><span style="float: right;">PPL1111</span></p>	<p>QE <span style="float: right;">140/160/170</span> <span style="float: right;">x3</span> <span style="float: right;">100/120</span> <span style="float: right;">x2</span></p>  <p><span style="float: right;">ROU37</span></p>
<p>PD <span style="float: right;">x1</span></p>  <p><span style="float: right;">PPL1080</span></p>	<p>PE <span style="float: right;">x1</span></p>  <p><span style="float: right;">PPL1081</span></p>	<p>JA <span style="float: right;">x1</span></p>  <p><span style="float: right;">AIM36</span></p>
<p>JD <span style="float: right;">x1</span></p>  <p>Lg=1894mm <span style="float: right;">J719</span></p>	<p>QD <span style="float: right;">x1</span></p>  <p><span style="float: right;">PGN36</span></p>	

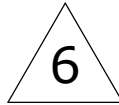

<p><b>VQ</b> <math>\varnothing 4.2</math> x6</p> <p>9.50</p> <p>1=1 VIS238</p>	<p><b>PF</b> 140/160/170 x4 100/120 x3</p> <p>PPL1099</p>	<p><b>VO</b> <math>\varnothing 3.5</math> x9</p> <p>6.50</p> <p>1=1 VIS253</p>
<p><b>PAK</b> 140/160/170 x5 100/120 x3</p> <p>SET105</p>	<p><b>VI</b> x3</p> <p>Lg=2800mm VEL06-5</p>	<p><b>VJ</b> x3</p> <p>Lg=2800mm VEL06-6</p>
<p><b>SG</b> x1</p> <ul style="list-style-type: none"> <li>● Montage gauche ● Left hand</li> <li>● Montaje a la izquierda</li> <li>● Montaggio a sinistra</li> <li>● Montage links ● Montage links</li> </ul> <p>SUP168</p>	<p><b>SH</b> x1</p> <ul style="list-style-type: none"> <li>● Montage droite ● Right hand</li> <li>● Montaje a la derecha</li> <li>● Montaggio a destra</li> <li>● Montage rechts ● Montage rechts</li> </ul> <p>SUP169</p>	<p><b>JJ</b> x2</p> <p>Lg=2200mm PFL84</p>
<p><b>AE</b> x1</p> <p>Lg=2030mm 6195-01</p>	<p><b>FA</b> x1</p> <p>125</p> <p>2055</p> <p>PUS132</p>	<p><b>FC</b> x1</p> <p>472</p> <p>2000</p> <p>PUS134</p>
<p><b>AH</b> x2</p> <p>Lg=1998mm 6197-01</p>		

● Outillage nécessaire ● Tools required ● Equipamiento necesario  
 ● Attrezzatura necessaria ● Benodigde gereedschap ● Werkzeuge erforderlich

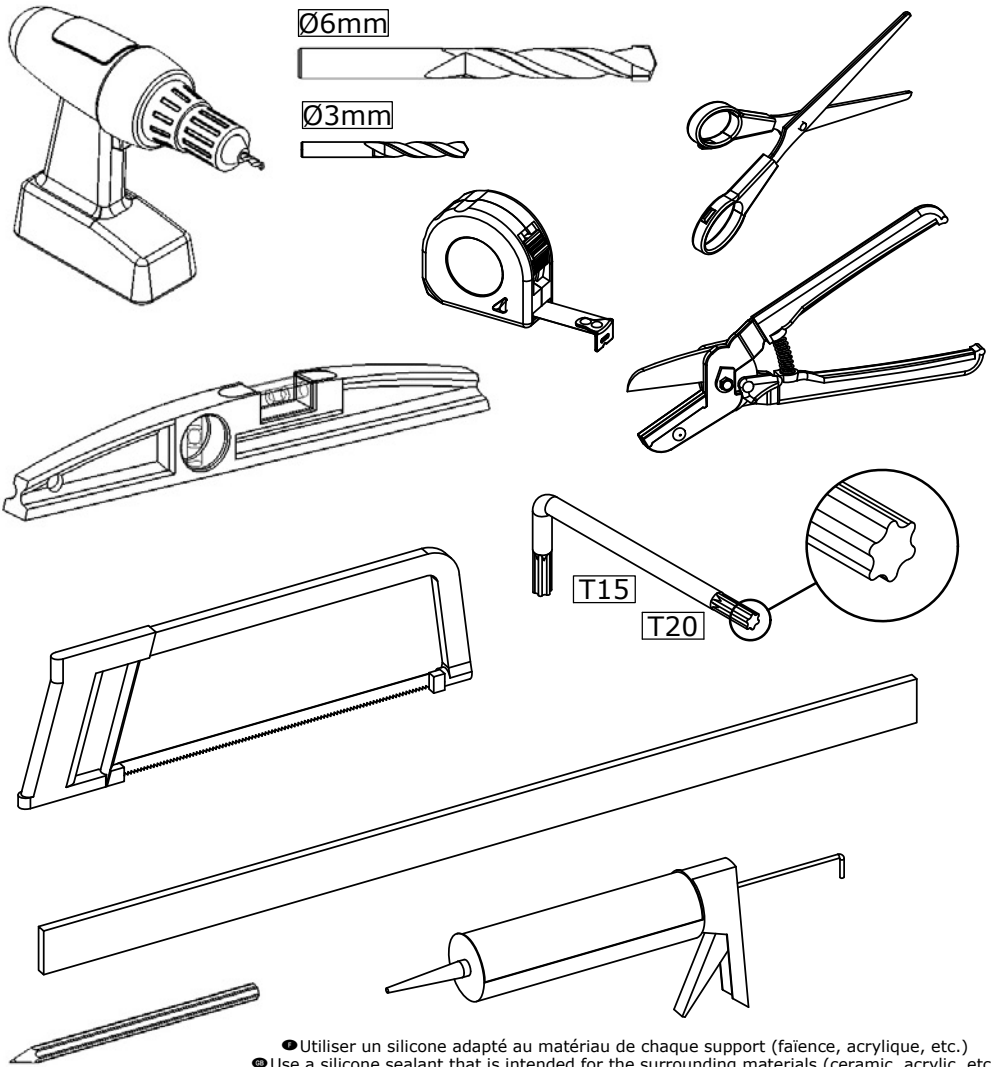

- Utiliser un silicone adapté au matériau de chaque support (faïence, acrylique, etc.)
- Use a silicone sealant that is intended for the surrounding materials (ceramic, acrylic, etc.)
  - Usar una silicona adecuada para cada tipo de material (loza, acrílico, etc.)
  - Utilizzare un silicone adatto a qualsiasi materiale (ceramica, acrilico, ecc.)
  - Gebruik siliconenkit die geschikt is voor iedere ondergrond (tegelwerk, acryl, etc.)
  - Für das jeweilige Trägermaterial (Stein, Acryl usw.) geeignetes Silikon verwenden.



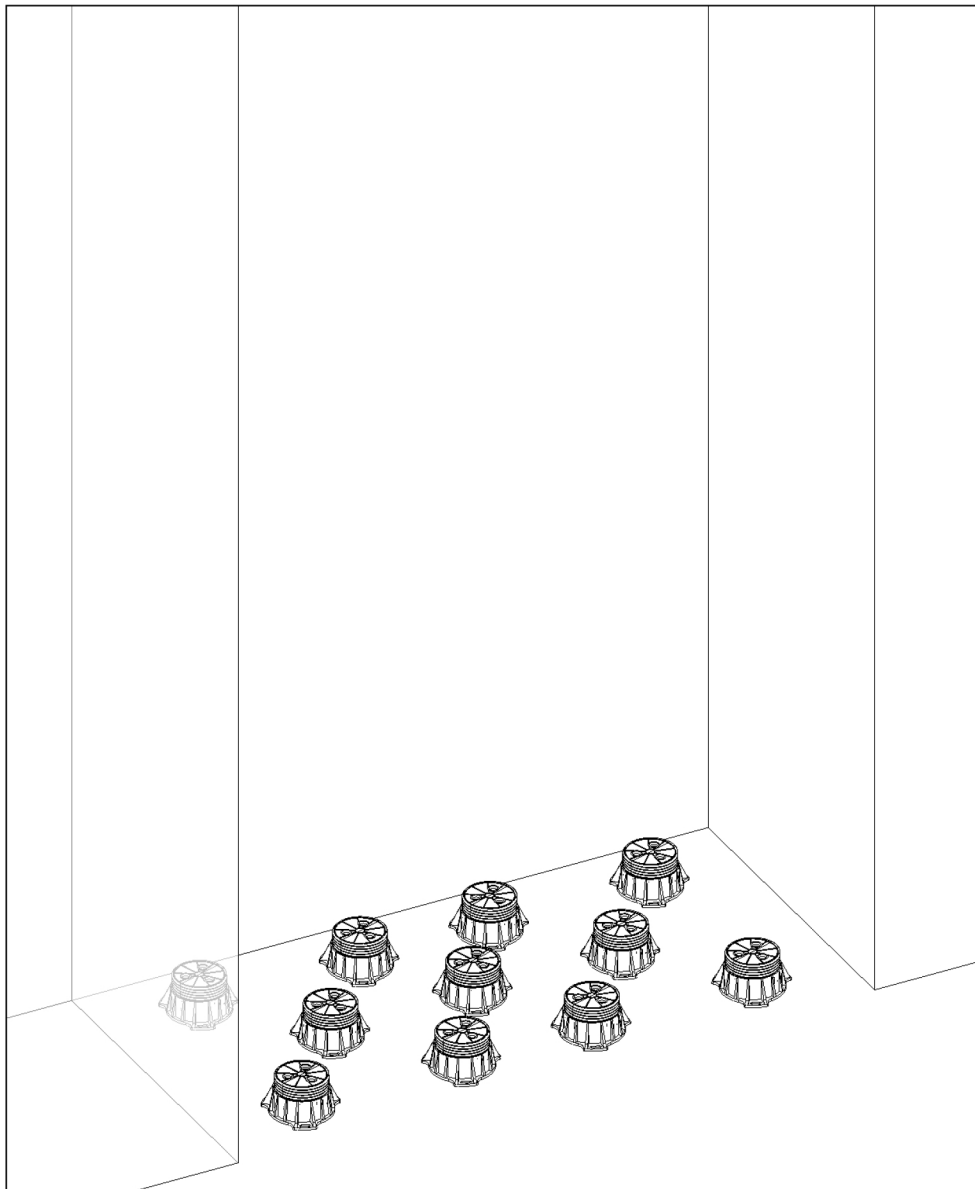
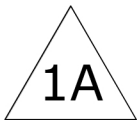

1B

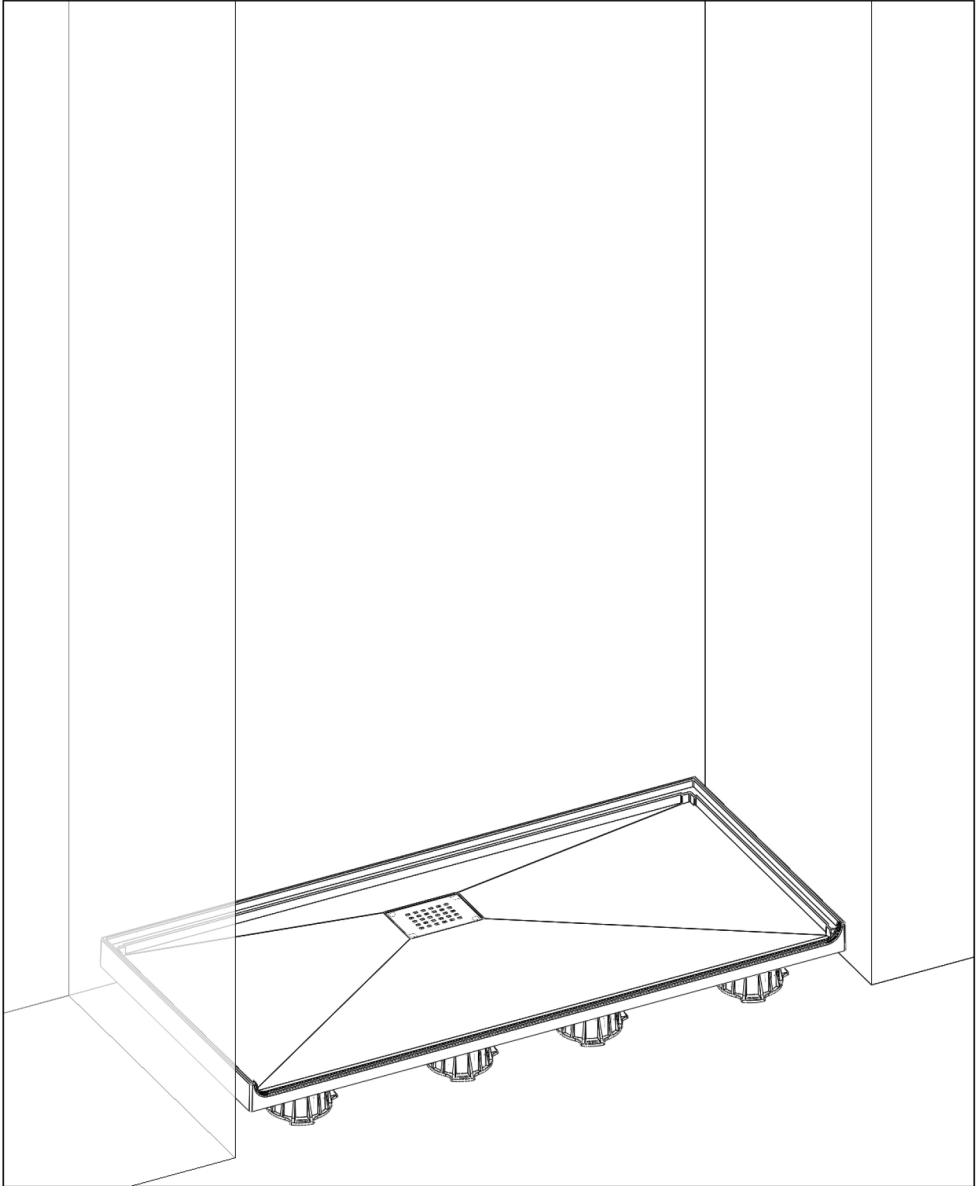

1C

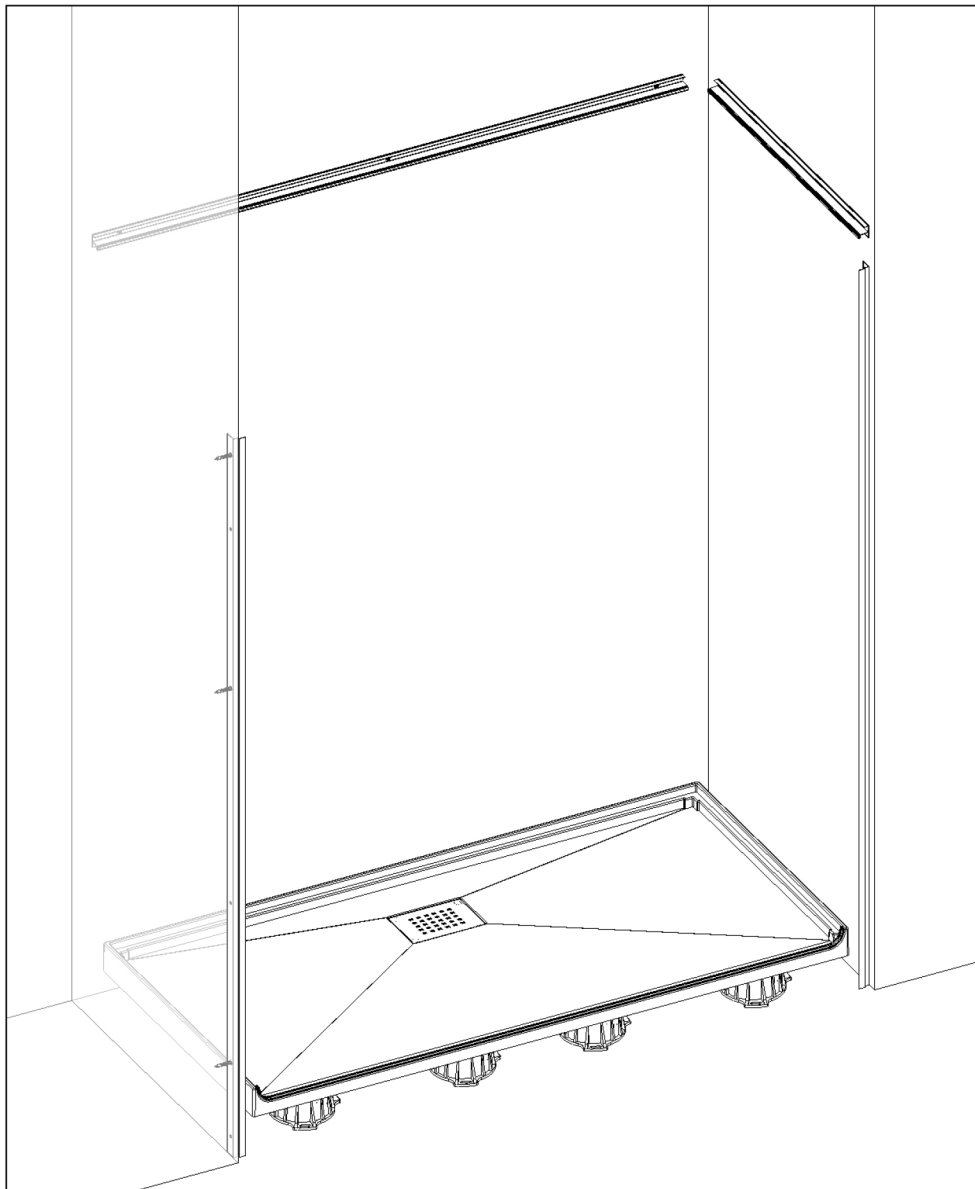

2

2A

2

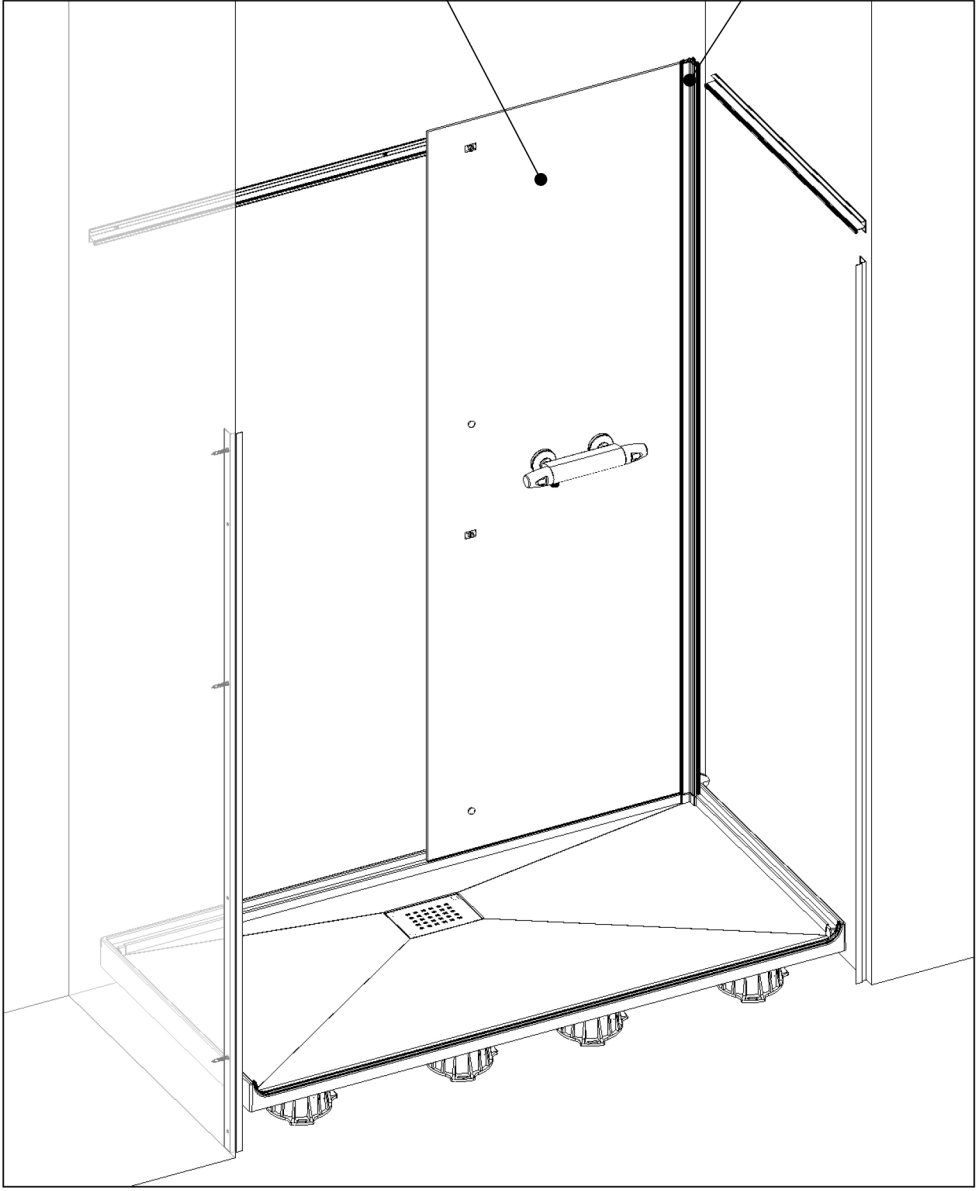

2

2B

2

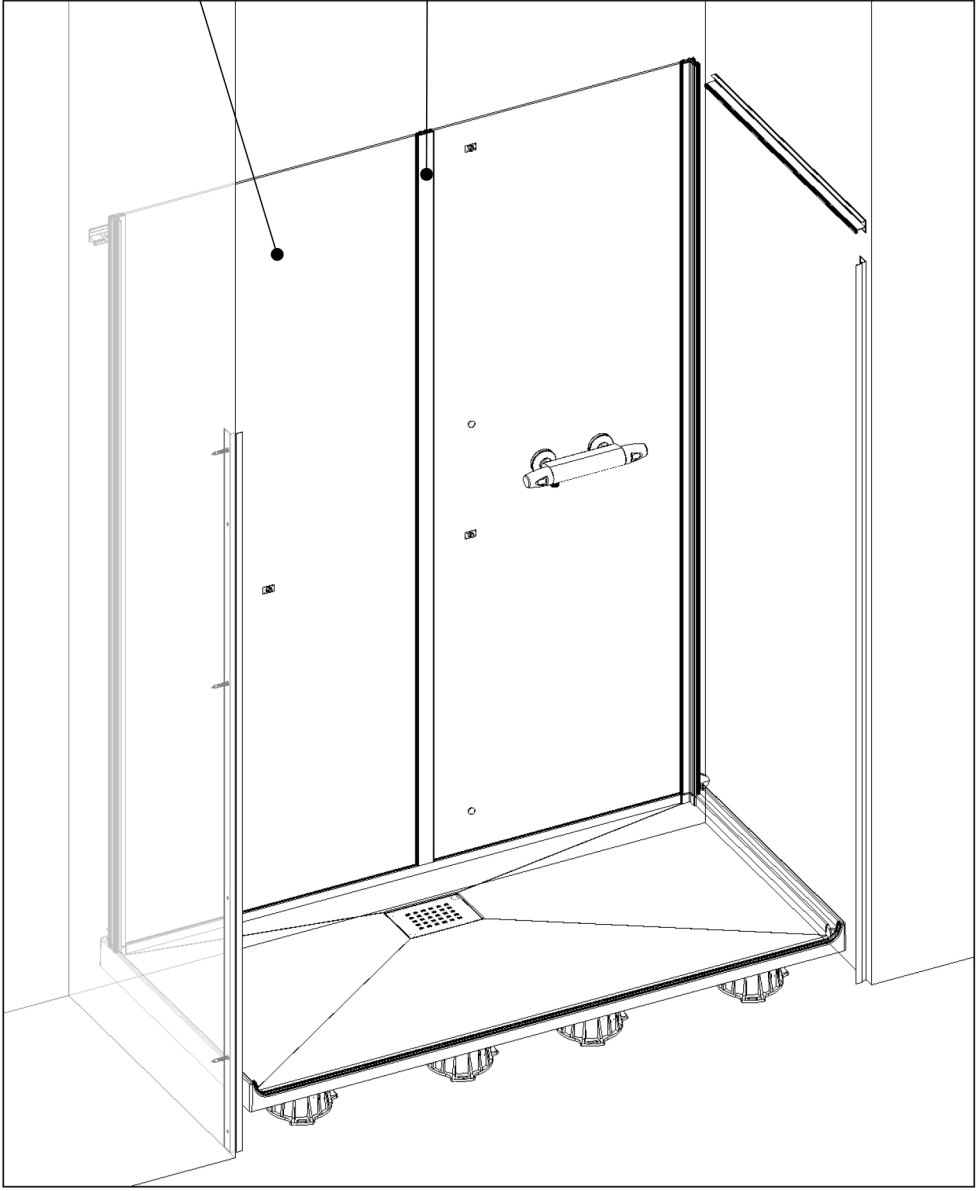

2

2C

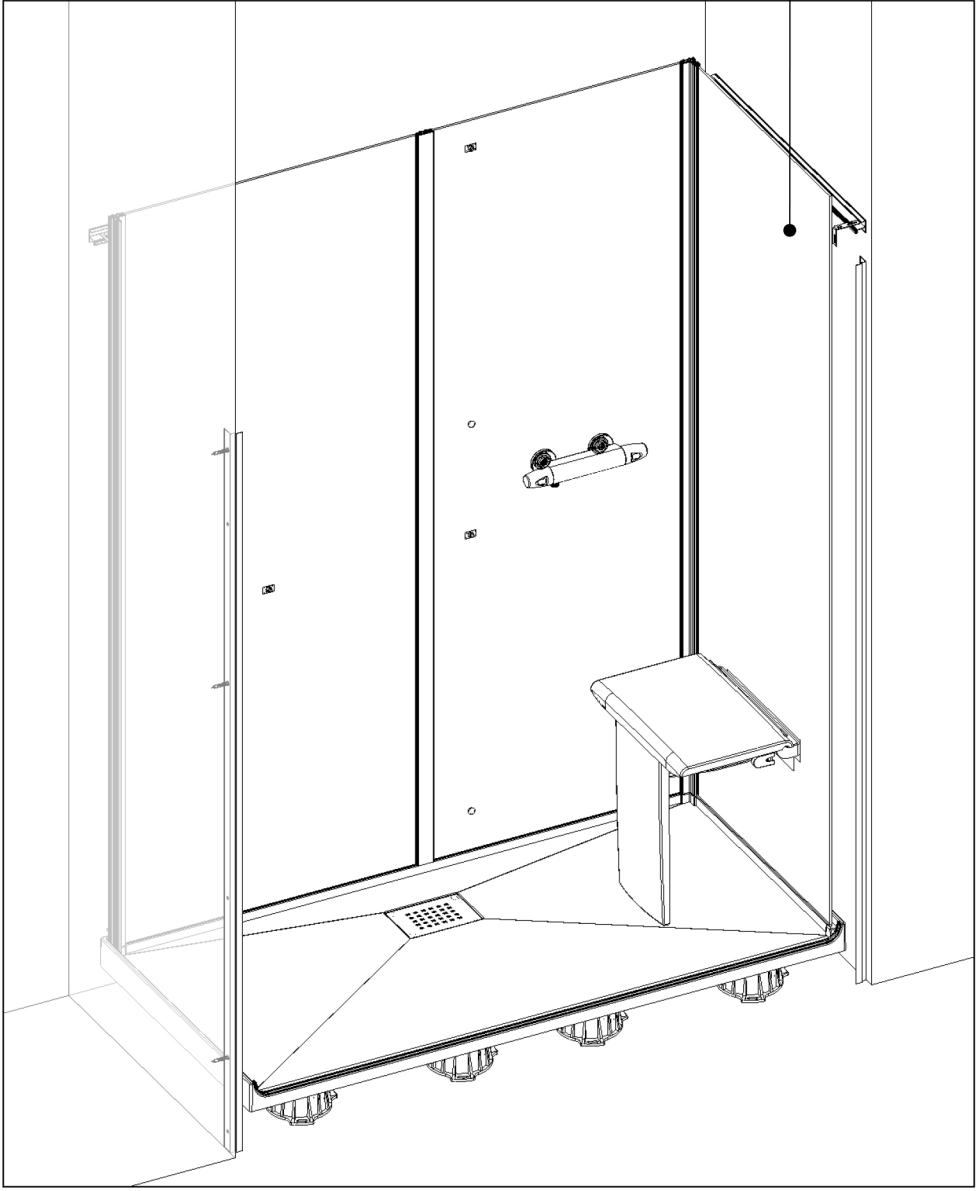

3

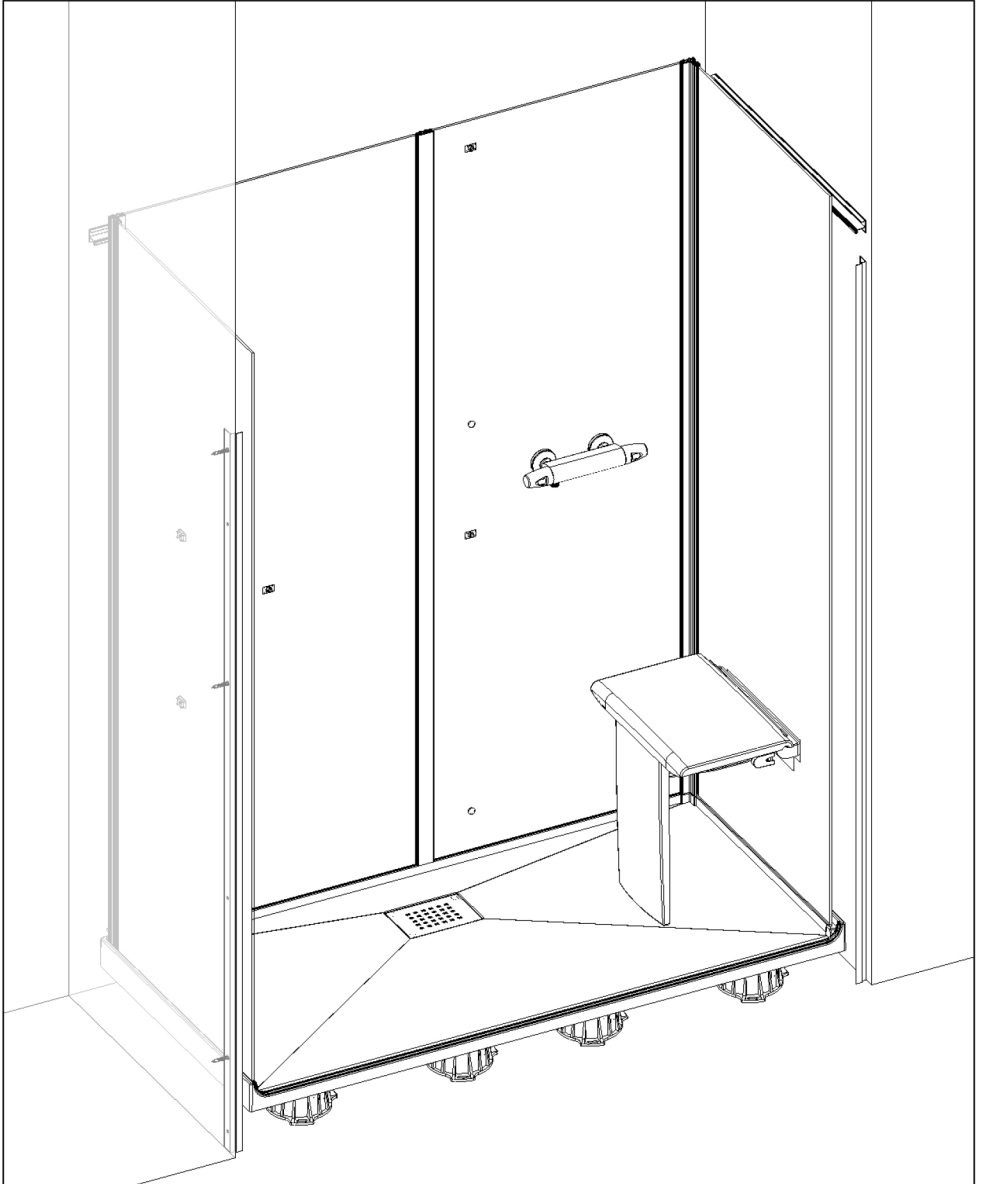

4

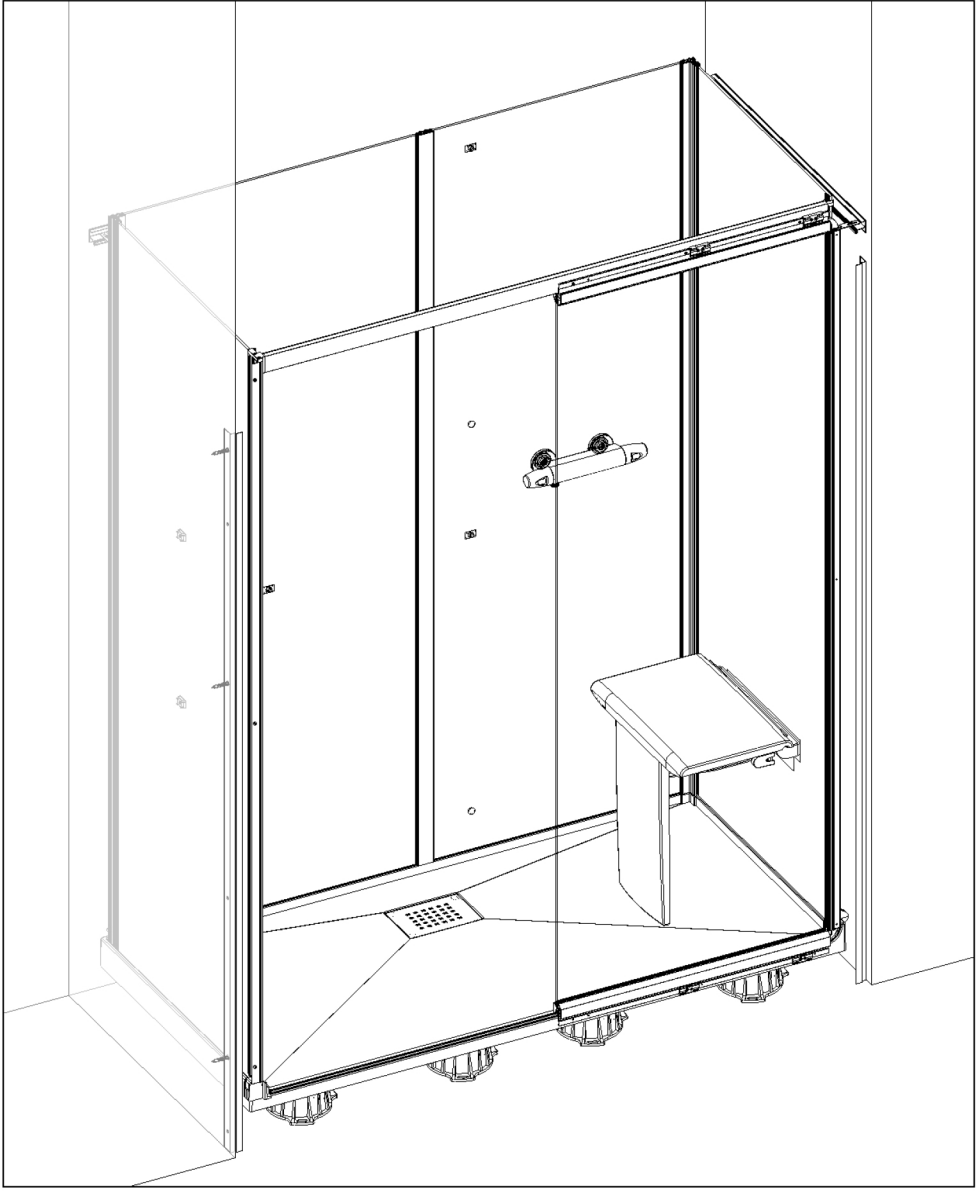

5

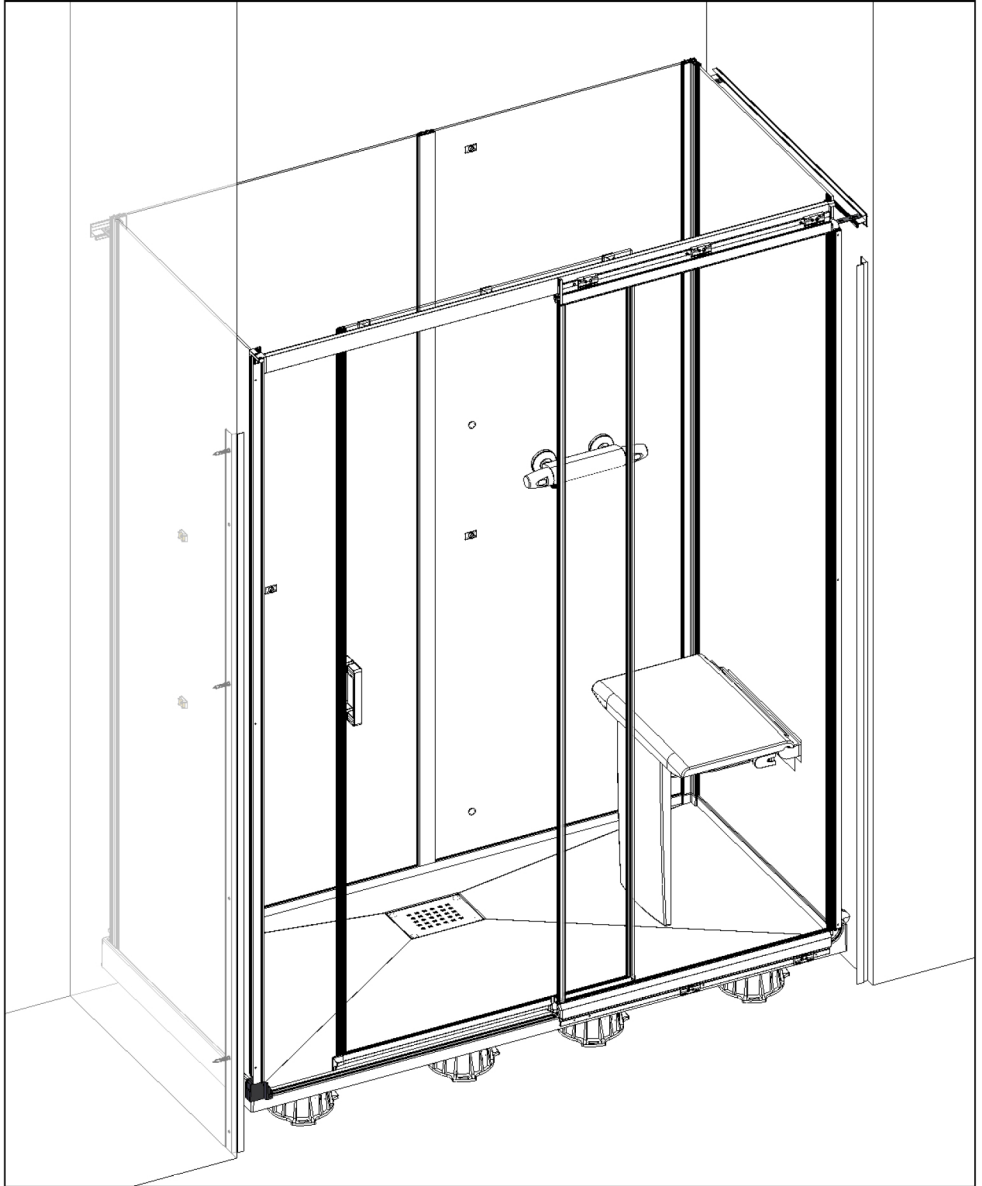

6

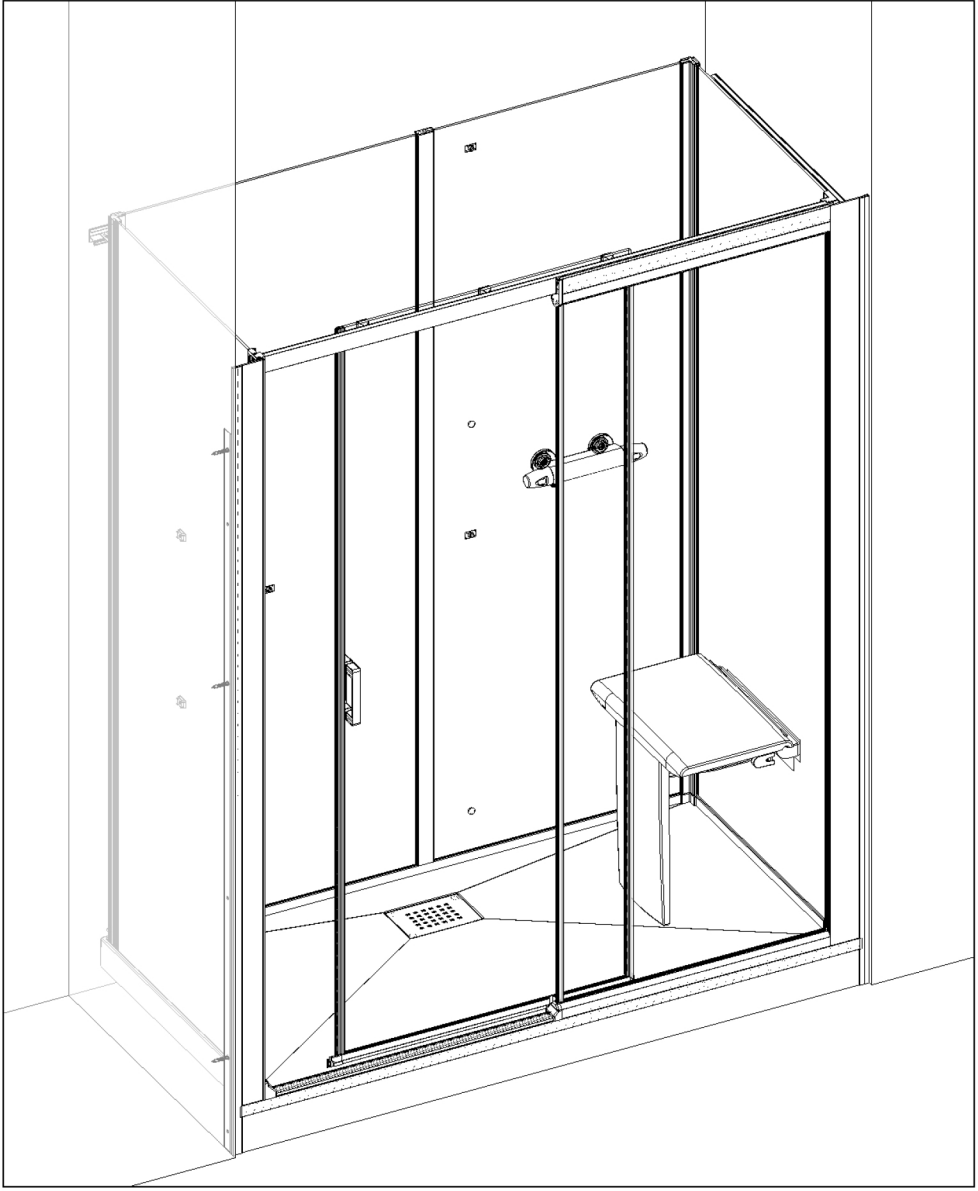

7

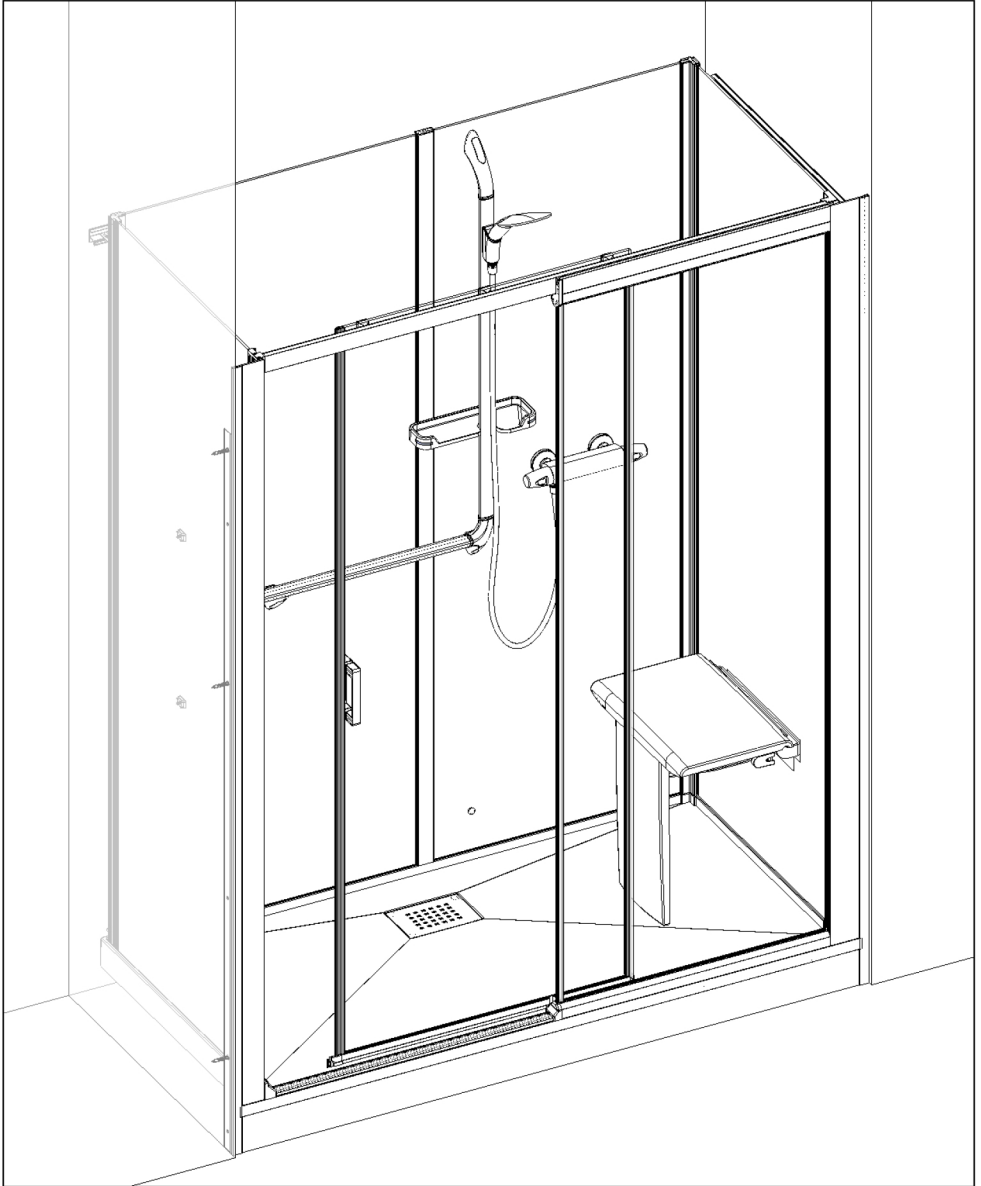

- Zone de décaissement pour un montage de receveur sans pieds
- Area required for the installation of the tray without feet
- Zona rebajada para la instalación del plato sin pies
- Zone necessarie per un montaggio del piatto senza piedi
- Aflooppgebied voor de montage van een douchebak zonder poten
- Freier Raum für Montage der Duschanne ohne FüÙe

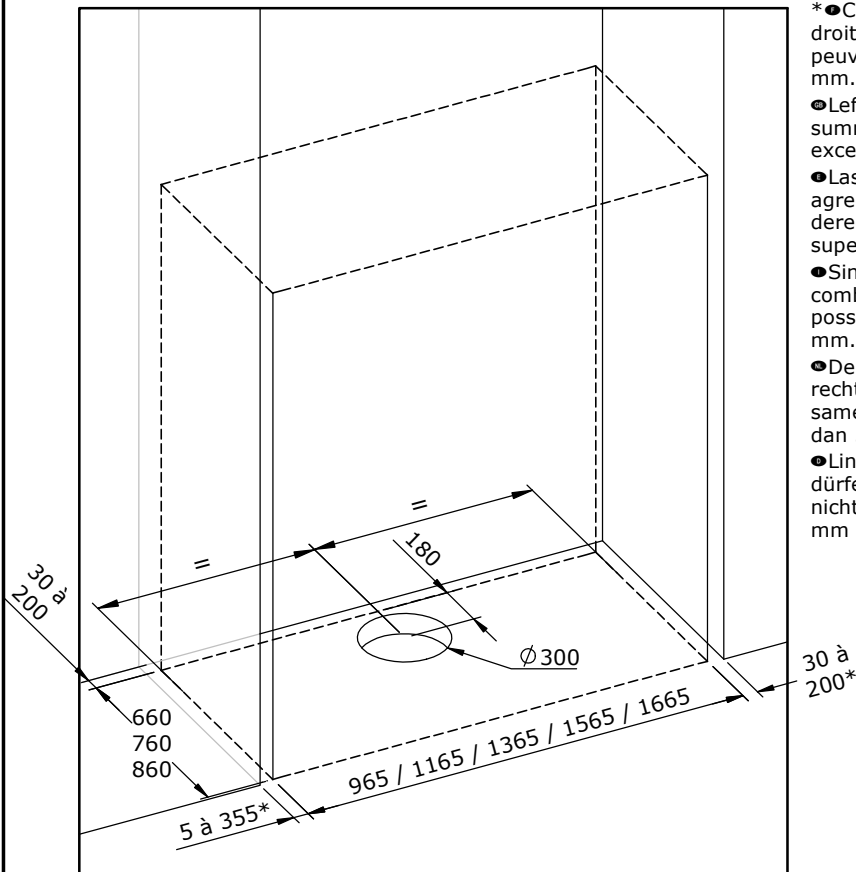

- \*● Côté gauche et droit cumulés ne peuvent excéder 385 mm.
- Left and right sides summed must not exceed 385 mm.
- Las cuotas agregadas izquierda y derecha no pueden superar 385 mm.
- Sinistra e destra combinati non possono superare 385 mm.
- De linker- en rechterzijde mogen samen niet groter zijn dan 385 mm.
- Links und rechts dürfen es zusammen nicht mehr als 385 mm sein.

- Cotes en mm ● Dimensions in mm ● Cotas en mm
- Quote in mm ● Afmetingen in mm ● Maße sind in mm angegeben

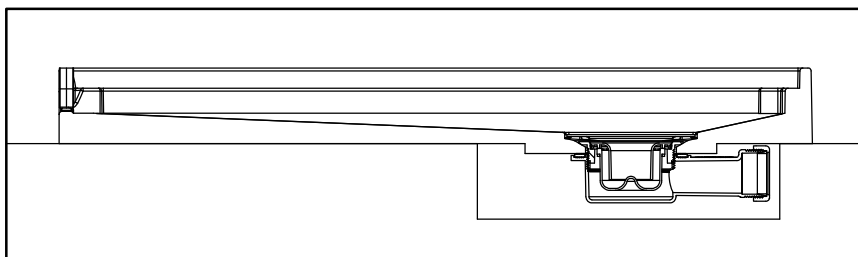



**SAV**  
**SERVICE HELPLINES**  
**ASSISTENZA POST-VENDITA**  
**SERVICIO POSTVENTA**

**FRANCE**

02 40 21 29 45

**SCHWEIZ**

(01) 748 17 44

**UK**

020 8842 0033

**ESPANA**

93 544 60 76

**IRELAND**

04697 33102

**NEDERLAND**

+31 475 487 100

**DEUTSCHLAND**

+49 (0) 6074 / 30928 0

**BELGIE**

+31 475 487 100

**ITALIA**

(0382) 6181

**BELGIQUE**

+31 475 487 100

**OSTEREICH**

+43 1 710 60 70

**РОССИЯ**

963 19 40, 773 67 22