

Notre service technique est
à votre écoute aux numéros
qui sont au dos de cette
notice d'installation

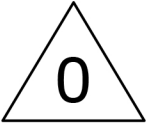

● Position de la cabine ● Position of the shower cubicle
 ● Posición de la cabina de ducha ● Posizione della cabina doccia
 ● Positie van de douchecabine ● Position der Duschkabine

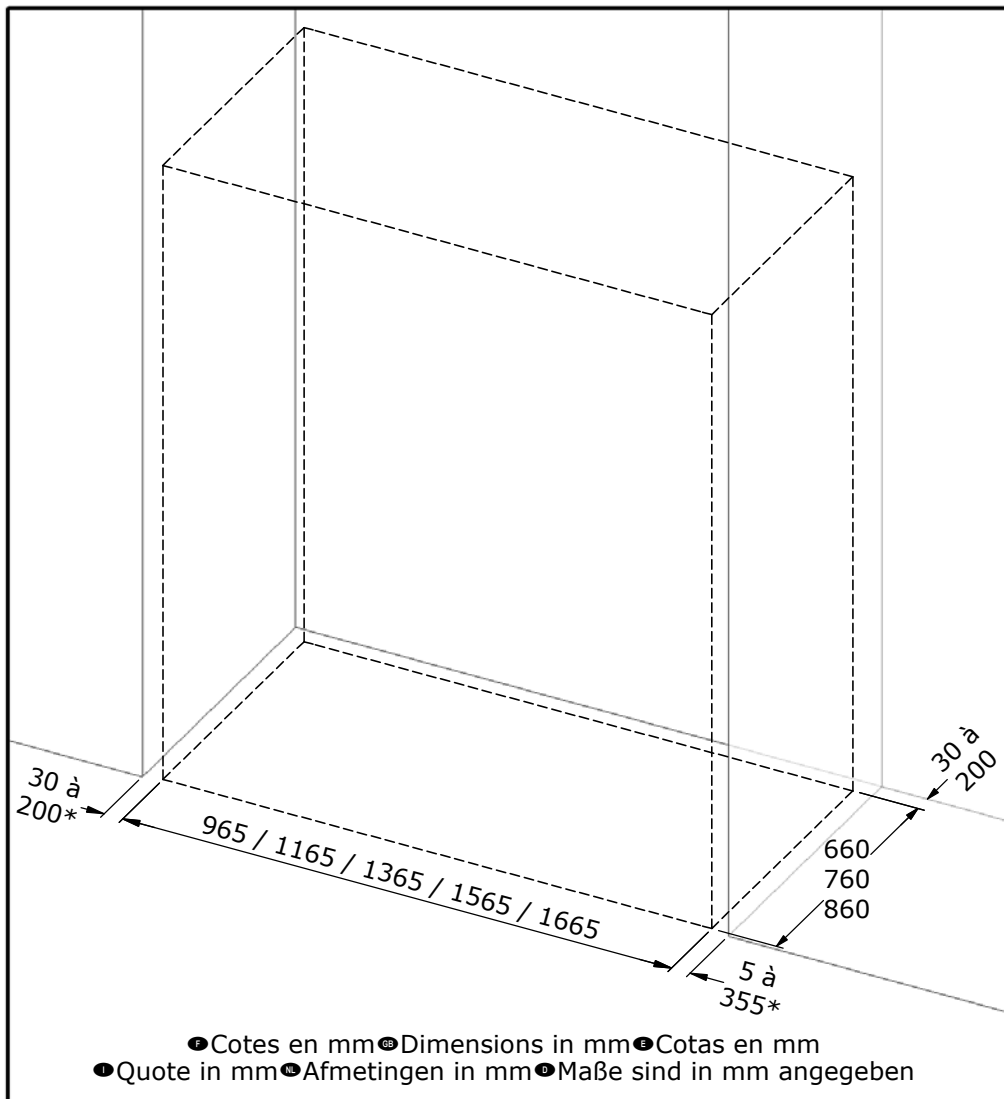

* ● Côté gauche et droit cumulés ne peuvent excéder 385 mm.

● Left and right sides summed must not exceed 385 mm.

● Las cuotas agregadas izquierda y derecha no pueden superar 385 mm.

● Sinistra e destra combinati non possono superare 385 mm.

● De linker- en rechterzijde mogen samen niet groter zijn dan 385 mm.

● Links und rechts dürfen es zusammen nicht mehr als 385 mm sein.

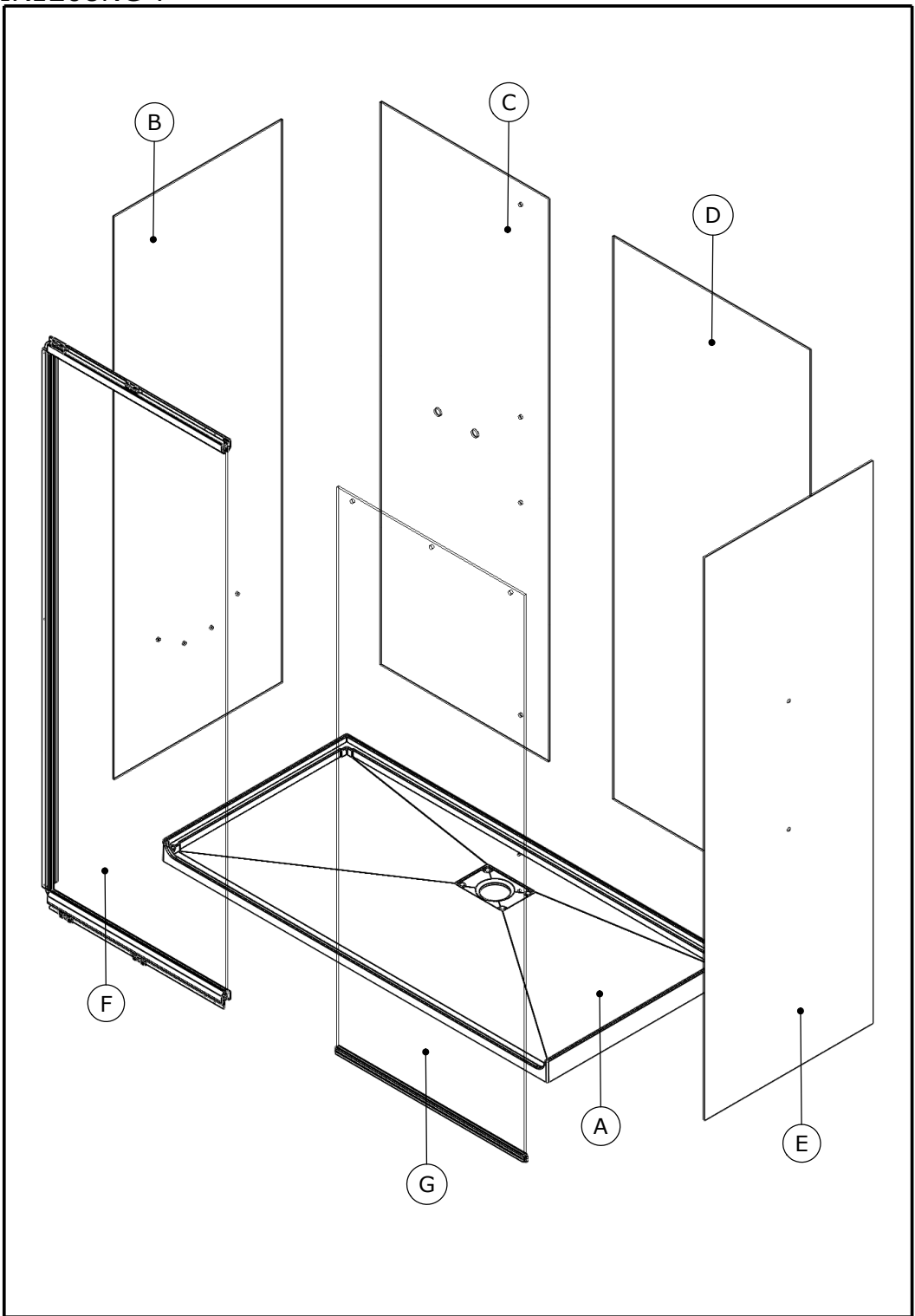

- CODE COLIS (Voir repères en page 4)
- PACKAGE CODES (See marks on page 4)
- REF. BULTOS (Ver pg. 4 para listado de bultos)
- CODE SET (zie blz. 4)
- Codering verpakking (zie omschrijving op pagina 4)
- PAKETCODES (siehe Kennzeichnungen auf Seite 4)

| REP | VERSION | 100 x 70 | 100 x 80 | 100 x 90 | 120 x 70 | 120 x 80 | 120 x 90 | 140 x 70 | 140 x 80 | 140 x 90 | 160 x 70 | 160 x 80 | 160 x 90 | 170 x 70 | 170 x 80 | 170 x 90 |
|-----|---------|----------|----------|----------|----------|----------|----------|----------|----------|----------|----------|----------|----------|----------|----------|----------|
| A | | RECS61 | RECS62 | RECS63 | RECS64 | RECS65 | RECS66 | RECS67 | RECS68 | RECS69 | RECS70 | RECS71 | RECS72 | RECS73 | RECS74 | RECS75 |
| B | | C11444E | C11445E | C11446E | C11444E | C11445E | C11446E | C11444E | C11445E | C11446E | C11444E | C11445E | C11446E | C11444E | C11445E | C11446E |
| C | | C11439E | | | C11431E | | | | | | | | | | | |
| D | | | | | C11440E | | | C11441E | | | C11442E | | | C11443E | | |
| E | | C11354E | C11355E | C11356E | C11354E | C11355E | C11356E | C11354E | C11355E | C11356E | C11354E | C11355E | C11356E | C11354E | C11355E | C11356E |
| F | SER | C11374E | | | C11375E | | | C11376E | | | C11377E | | | C11378E | | |
| | TN | C11369E | | | C11370E | | | C11371E | | | C11372E | | | C11373E | | |
| G | SER | C11394E | | | C11395E | | | C11396E | | | C11397E | | | C11398E | | |
| | TN | C11389E | | | C11390E | | | C11391E | | | C11392E | | | C11393E | | |

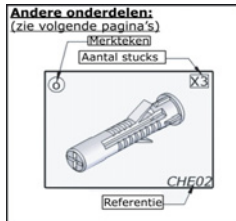
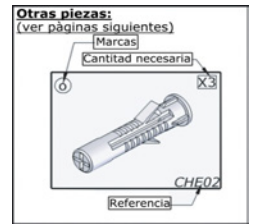
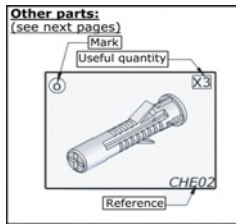
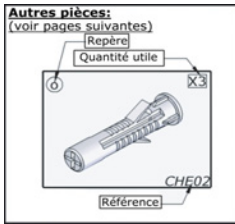

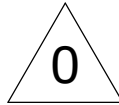

| | | |
|---|--|---|
| <p>SK</p> <ul style="list-style-type: none"> ● Montage gauche ● Left hand ● Montaje a la izquierda ● Montaggio a sinistra ● Montage links ● Montage links <p>SUP172 x1</p> | <p>SL</p> <ul style="list-style-type: none"> ● Montage droite ● Right hand ● Montaje a la derecha ● Montaggio a destra ● Montage rechts ● Montage rechts <p>SUP173 x1</p> | <p>PS</p> <p>PPL1116 x2</p> |
| <p>SC</p> <ul style="list-style-type: none"> ● Montage gauche ● Left hand ● Montaje a la izquierda ● Montaggio a sinistra ● Montage links ● Montage links <p>SUP164 x1</p> | <p>SD</p> <ul style="list-style-type: none"> ● Montage droite ● Right hand ● Montaje a la derecha ● Montaggio a destra ● Montage rechts ● Montage rechts <p>SUP165 x1</p> | <p>PT 120/140/160/170 x1</p> <p>100 x0</p> <p>PPL1117</p> |
| <p>PG</p> <ul style="list-style-type: none"> ● Montage gauche ● Left hand ● Montaje a la izquierda ● Montaggio a sinistra ● Montage links ● Montage links <p>PPL1102 x1</p> | <p>PH</p> <ul style="list-style-type: none"> ● Montage droite ● Right hand ● Montaje a la derecha ● Montaggio a destra ● Montage rechts ● Montage rechts <p>PPL1103 x1</p> | <p>MA x1</p> <p>MIT100</p> |
| <p>PAB</p> <ul style="list-style-type: none"> ● Montage gauche ● Left hand ● Montaje a la izquierda ● Montaggio a sinistra ● Montage links ● Montage links <p>PPL1134 x1</p> | <p>PAC</p> <ul style="list-style-type: none"> ● Montage droite ● Right hand ● Montaje a la derecha ● Montaggio a destra ● Montage rechts ● Montage rechts <p>PPL1135 x1</p> | <p>MB x1</p> <p>MIT94</p> |
| <p>PAX</p> <p>PPL1318 x4</p> | <p>VG</p> <p>SET03 x2</p> | <p>MIT94</p> |

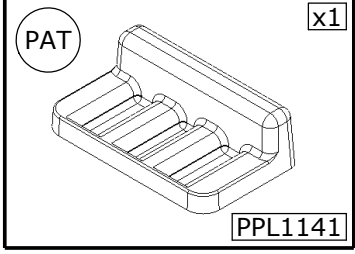
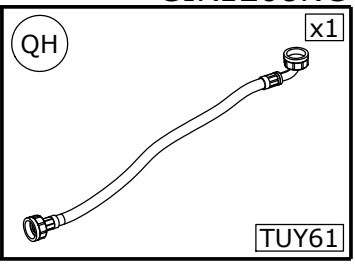
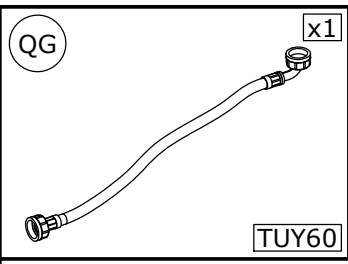
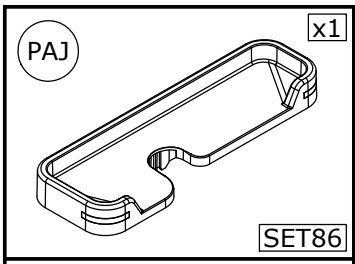

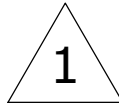

| <p>PA 120/140/160/170 x11 100 x9</p> <p>PPL802</p> | <p>PB 120/140/160/170 x11 100 x9</p> <p>PPL804</p> | <p>QA</p> <p>BOND28</p> | | | | | | | | | | | | | |
|--|--|---------------------------------------|--|-----------------------------|--------------------------------|-----|----------|-----|-----------|-----|-----------|-----|-----------|-----|-----------|
| <p>TA x1</p> <p>TOL11</p> | <p>VN Ø4 x11</p> <p>45</p> <p>1=1 VIS231</p> | | | | | | | | | | | | | | |
| <p>VA x11</p> <p>CHE02</p> | <p>VV x11</p> <p>RON34</p> | <p>AU x2</p> <p>Lg=1940mm 6210-01</p> | | | | | | | | | | | | | |
| <p>AA x1</p> <p>Lg=1972mm 6189-01</p> | <p>AS x11</p> <table border="1"> <thead> <tr> <th colspan="2">6209</th> </tr> <tr> <th>● Longueur ● Length ● Largo</th> <th>● Lunghezza ● Lengte ● Länge</th> </tr> </thead> <tbody> <tr> <td>100</td> <td>Lg=950mm</td> </tr> <tr> <td>120</td> <td>Lg=1150mm</td> </tr> <tr> <td>140</td> <td>Lg=1350mm</td> </tr> <tr> <td>160</td> <td>Lg=1550mm</td> </tr> <tr> <td>170</td> <td>Lg=1650mm</td> </tr> </tbody> </table> | 6209 | | ● Longueur ● Length ● Largo | ● Lunghezza ● Lengte ● Länge | 100 | Lg=950mm | 120 | Lg=1150mm | 140 | Lg=1350mm | 160 | Lg=1550mm | 170 | Lg=1650mm |
| 6209 | | | | | | | | | | | | | | | |
| ● Longueur ● Length ● Largo | ● Lunghezza ● Lengte ● Länge | | | | | | | | | | | | | | |
| 100 | Lg=950mm | | | | | | | | | | | | | | |
| 120 | Lg=1150mm | | | | | | | | | | | | | | |
| 140 | Lg=1350mm | | | | | | | | | | | | | | |
| 160 | Lg=1550mm | | | | | | | | | | | | | | |
| 170 | Lg=1650mm | | | | | | | | | | | | | | |
| <p>AB 120/140/160/170 x1 100 x0</p> <p>Lg=1972mm 6190-01</p> | <p>AT x1</p> <table border="1"> <thead> <tr> <th colspan="2">6209</th> </tr> <tr> <th>● Largeur ● Width ● Ancho</th> <th>● Larghezza ● Breedte ● Breite</th> </tr> </thead> <tbody> <tr> <td>70</td> <td>Lg=635mm</td> </tr> <tr> <td>80</td> <td>Lg=735mm</td> </tr> <tr> <td>90</td> <td>Lg=835mm</td> </tr> </tbody> </table> | 6209 | | ● Largeur ● Width ● Ancho | ● Larghezza ● Breedte ● Breite | 70 | Lg=635mm | 80 | Lg=735mm | 90 | Lg=835mm | | | | |
| 6209 | | | | | | | | | | | | | | | |
| ● Largeur ● Width ● Ancho | ● Larghezza ● Breedte ● Breite | | | | | | | | | | | | | | |
| 70 | Lg=635mm | | | | | | | | | | | | | | |
| 80 | Lg=735mm | | | | | | | | | | | | | | |
| 90 | Lg=835mm | | | | | | | | | | | | | | |

2

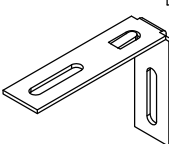
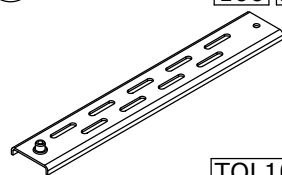
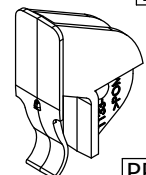
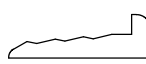
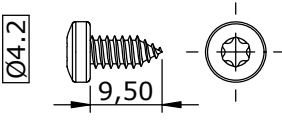
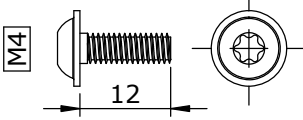
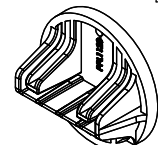
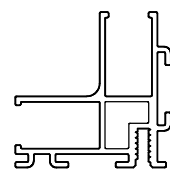
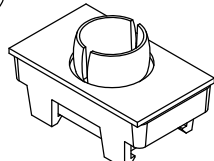
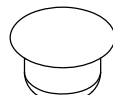
| | | |
|--|---|--|
| <p>TE 120/140/160/170 x6 100 x4</p>  <p>TOL102</p> | <p>TF 120/140/160/170 x6 100 x4</p>  <p>TOL103</p> | <p>PAA 120/140/160/170 x5 100 x4</p>  <p>PPL1133</p> |
| <p>JG 120/140/160/170 x6 100 x4</p>  <p>Lg=1971mm</p> <p>P101</p> | <p>VQ 120/140/160/170 x5 100 x4</p>  <p>Ø4.2 9,50</p> <p>1=1</p> <p>VIS238</p> | <p>VR 120/140/160/170 x6 100 x4</p>  <p>M4 12</p> <p>1=1</p> <p>VIS239</p> |
| <p>PAL 120/140/160/170 x1 100 x0</p>  <p>PPL1128</p> | <p>AA x1</p>  <p>Lg=1972mm</p> <p>6189-01</p> | <p>VD x3</p>  <p>SET88</p> |
| <p>QB 120/140/160/170 x2 100 x3</p>  <p>BOU40</p> | | |

3

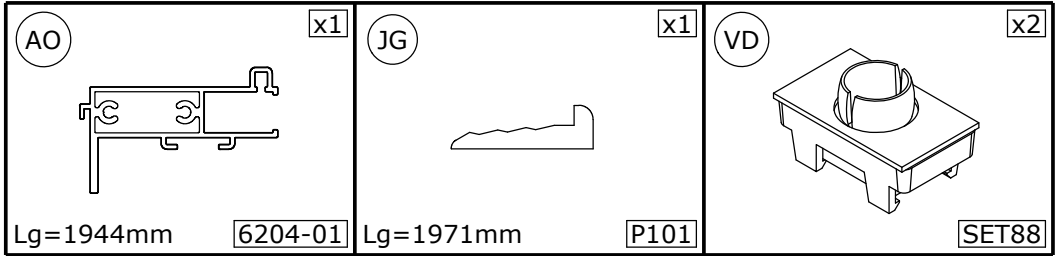

4

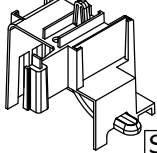
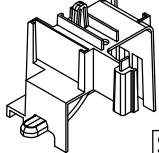
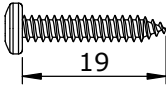
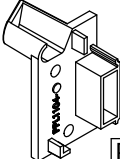
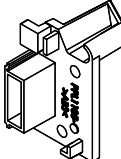
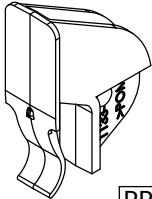
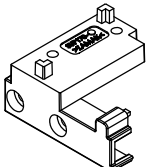
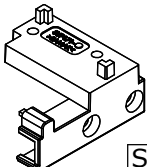
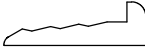
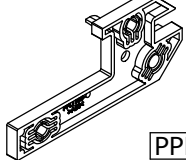
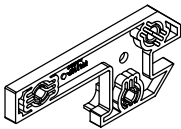
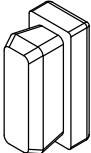
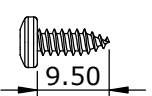
| | | | |
|---|--|--|--|
| <p>SA</p> <ul style="list-style-type: none"> ● Montage gauche ● Left hand ● Montaje a la izquierda ● Montaggio a sinistra ● Montage links ● Montage links  <p>SET107</p> <p>x1</p> | <p>SB</p> <ul style="list-style-type: none"> ● Montage droite ● Right hand ● Montaje a la derecha ● Montaggio a destra ● Montage rechts ● Montage rechts  <p>SET108</p> <p>x1</p> | <p>VM</p> <p>$\varnothing 3.5$</p>  <p>19</p> <p>1=1</p> <p>VIS215</p> <p>x8</p> | |
| <p>PI</p> <ul style="list-style-type: none"> ● Montage gauche ● Left hand ● Montaje a la izquierda ● Montaggio a sinistra ● Montage links ● Montage links  <p>PPL1104</p> <p>x1</p> | <p>PJ</p> <ul style="list-style-type: none"> ● Montage droite ● Right hand ● Montaje a la derecha ● Montaggio a destra ● Montage rechts ● Montage rechts  <p>PPL1105</p> <p>x1</p> | <p>PAA</p>  <p>PPL1133</p> <p>x1</p> | |
| <p>SI</p> <ul style="list-style-type: none"> ● Montage gauche ● Left hand ● Montaje a la izquierda ● Montaggio a sinistra ● Montage links ● Montage links  <p>SUP170</p> <p>x1</p> | <p>SJ</p> <ul style="list-style-type: none"> ● Montage droite ● Right hand ● Montaje a la derecha ● Montaggio a destra ● Montage rechts ● Montage rechts  <p>SUP171</p> <p>x1</p> | <p>JG</p>  <p>Lg=1971mm</p> <p>P101</p> <p>x1</p> | |
| <p>PK</p> <ul style="list-style-type: none"> ● Montage gauche ● Left hand ● Montaje a la izquierda ● Montaggio a sinistra ● Montage links ● Montage links  <p>PPL1106</p> <p>x1</p> | <p>PL</p> <ul style="list-style-type: none"> ● Montage droite ● Right hand ● Montaje a la derecha ● Montaggio a destra ● Montage rechts ● Montage rechts  <p>PPL1107</p> <p>x1</p> | <p>QC</p>  <p>BUT22</p> <p>x1</p> | |
| <p>VP</p> <p>$\varnothing 3.5$</p>  <p>9.50</p> <p>1=1</p> <p>VIS237</p> <p>x3</p> | | | |

AG x1

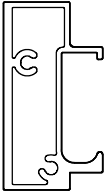

| 6196 | | |
|-------------|----------|-----------|
| ● Longueur | ● Length | ● Largo |
| ● Lunghezza | ● Lengte | ● Länge |
| 100 | | Lg=880mm |
| 120 | | Lg=1080mm |
| 140 | | Lg=1280mm |
| 160 | | Lg=1480mm |
| 170 | | Lg=1580mm |

AD x1

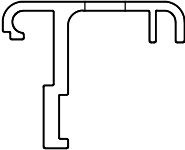

| 6194 | | |
|-------------|----------|----------|
| ● Longueur | ● Length | ● Largo |
| ● Lunghezza | ● Lengte | ● Länge |
| 100 | | Lg=456mm |
| 120 | | Lg=556mm |
| 140 | | Lg=656mm |
| 160 | | Lg=756mm |
| 170 | | Lg=806mm |

AJ x1



| 6199 | | |
|-------------|----------|----------|
| ● Longueur | ● Length | ● Largo |
| ● Lunghezza | ● Lengte | ● Länge |
| 100 | | Lg=401mm |
| 120 | | Lg=501mm |
| 140 | | Lg=601mm |
| 160 | | Lg=701mm |
| 170 | | Lg=751mm |

AQ x2

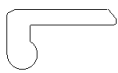

Lg=300mm 6206-01

5

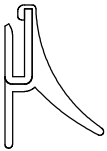
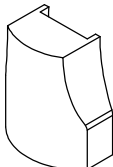
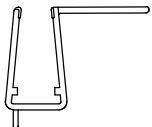
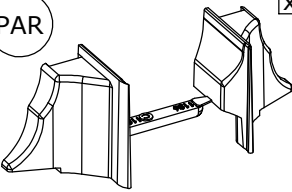
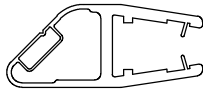
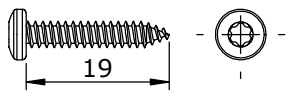
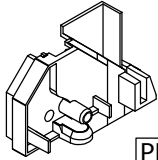
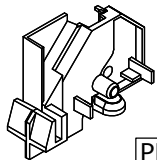
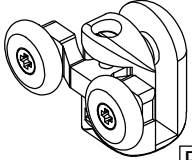
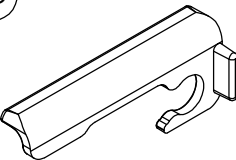
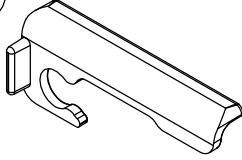
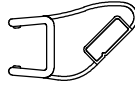
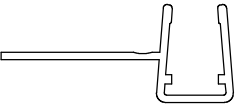
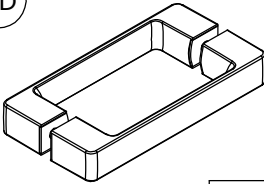
| | | |
|--|---|---|
| <p>JE x1</p>  <p>Lg=820mm JOI239</p> | <p>PC x1</p>  <p>PPL823</p> | <p>JC x1</p>  <p>Lg=1882mm J723</p> |
| <p>PAR x1</p>  <p>PPL1136/1137</p> | <p>JB x1</p>  <p>Lg=1959mm AI150</p> | <p>VM Ø3.5 x1</p>  <p>1=1 VIS215</p> |
| <p>PO x1</p> <ul style="list-style-type: none"> ● Montage gauche ● Left hand ● Montaje a la izquierda ● Montaggio a sinistra ● Montage links ● Montage links  <p>PPL1110</p> | <p>PP x1</p> <ul style="list-style-type: none"> ● Montage droite ● Right hand ● Montaje a la derecha ● Montaggio a destra ● Montage rechts ● Montage rechts  <p>PPL1111</p> | <p>QE 140/160/170 x3</p> <p>100/120 x2</p>  <p>ROU37</p> |
| <p>PD x1</p>  <p>PPL1080</p> | <p>PE x1</p>  <p>PPL1081</p> | <p>JA x1</p>  <p>AIM36</p> |
| <p>JD x1</p>  <p>Lg=1894mm J719</p> | <p>QD x1</p>  <p>PGN36</p> | |

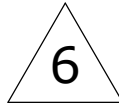

| | | |
|---|--|--|
| <p>VQ $\varnothing 4.2$ x6</p> <p>9.50</p> <p>1=1 VIS238</p> | <p>PF 140/160/170 x4 100/120 x3</p> <p>PPL1099</p> | <p>VO $\varnothing 3.5$ x9</p> <p>6.50</p> <p>1=1 VIS253</p> |
| <p>PAK 140/160/170 x5 100/120 x3</p> <p>SET105</p> | <p>VI x3</p> <p>Lg=2800mm VEL06-5</p> | <p>VJ x3</p> <p>Lg=2800mm VEL06-6</p> |
| <p>SG x1</p> <ul style="list-style-type: none"> ● Montage gauche ● Left hand ● Montaje a la izquierda ● Montaggio a sinistra ● Montage links ● Montage links <p>SUP168</p> | <p>SH x1</p> <ul style="list-style-type: none"> ● Montage droite ● Right hand ● Montaje a la derecha ● Montaggio a destra ● Montage rechts ● Montage rechts <p>SUP169</p> | <p>JJ x2</p> <p>Lg=2200mm PFL84</p> |
| <p>AE x1</p> <p>Lg=2030mm 6195-01</p> | <p>FA x1</p> <p>125</p> <p>2055</p> <p>PUS132</p> | <p>FC x1</p> <p>472</p> <p>2000</p> <p>PUS134</p> |
| <p>AH x2</p> <p>Lg=1998mm 6197-01</p> | | |

● Outillage nécessaire ● Tools required ● Equipamiento necesario
 ● Attrezzatura necessaria ● Benodigde gereedschap ● Werkzeuge erforderlich

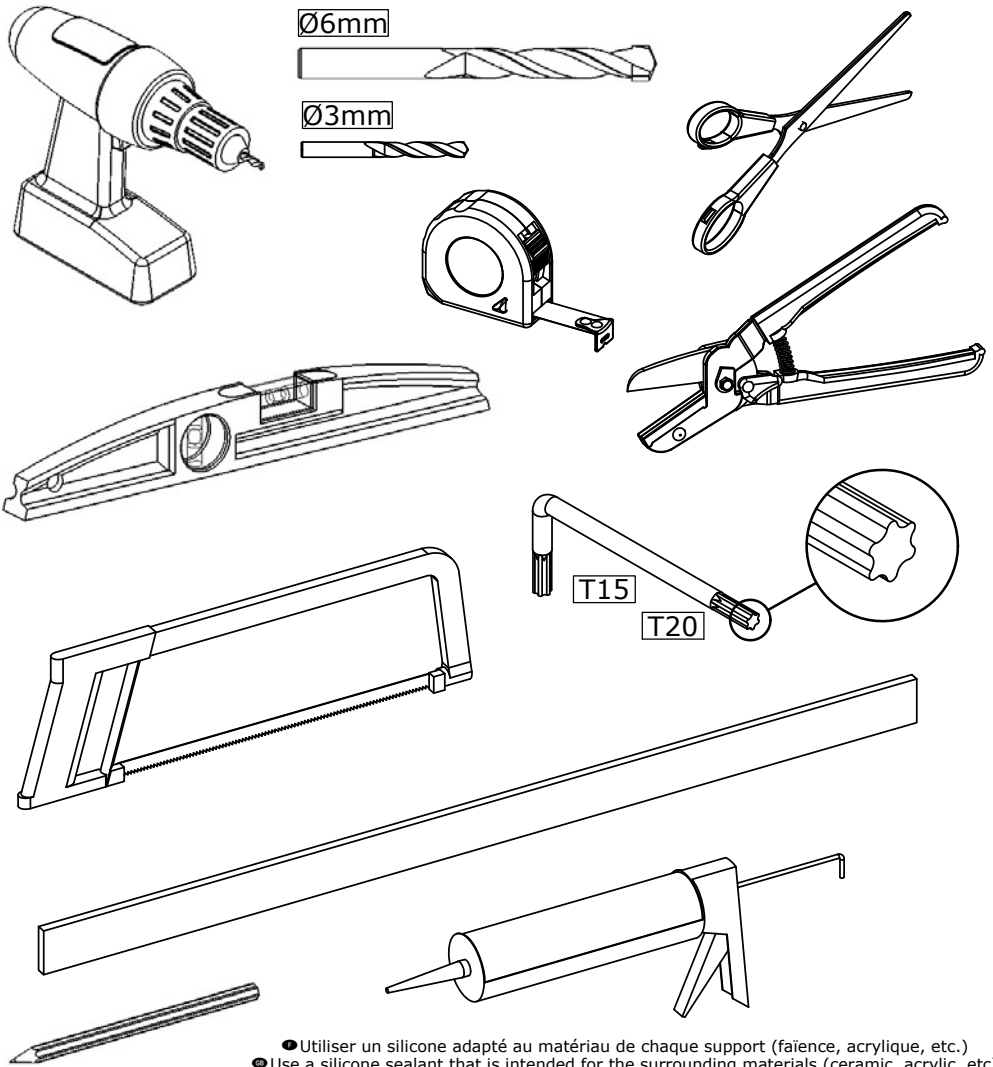

- Utiliser un silicone adapté au matériau de chaque support (faïence, acrylique, etc.)
- Use a silicone sealant that is intended for the surrounding materials (ceramic, acrylic, etc.)
- Usar una silicona adecuada para cada tipo de material (loza, acrílico, etc.)
- Utilizzare un silicone adatto a qualsiasi materiale (ceramica, acrilico, ecc.)
- Gebruik siliconenkit die geschikt is voor iedere ondergrond (tegelwerk, acryl, etc.)
- Für das jeweilige Trägermaterial (Stein, Acryl usw.) geeignetes Silikon verwenden.



1A

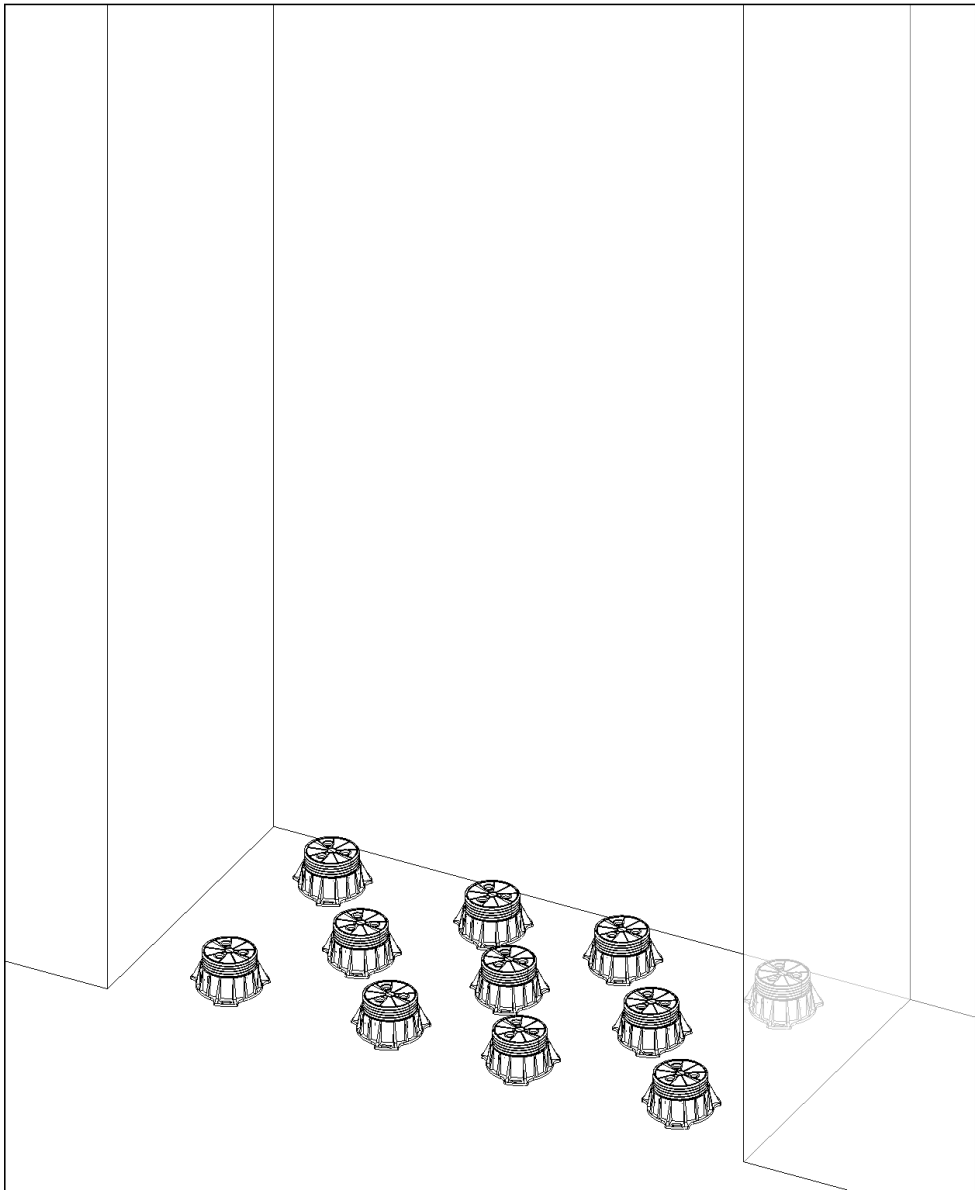

1B

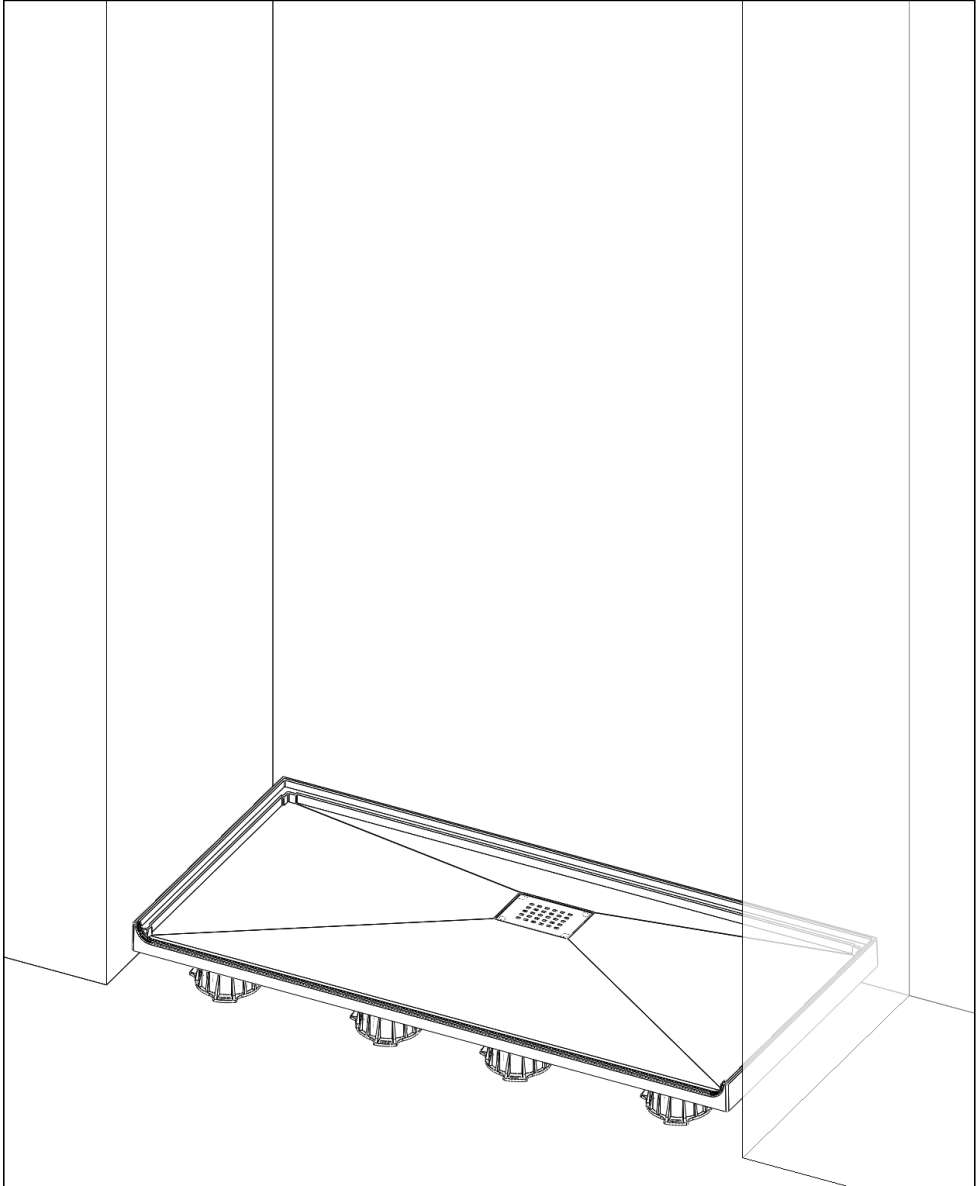

1C

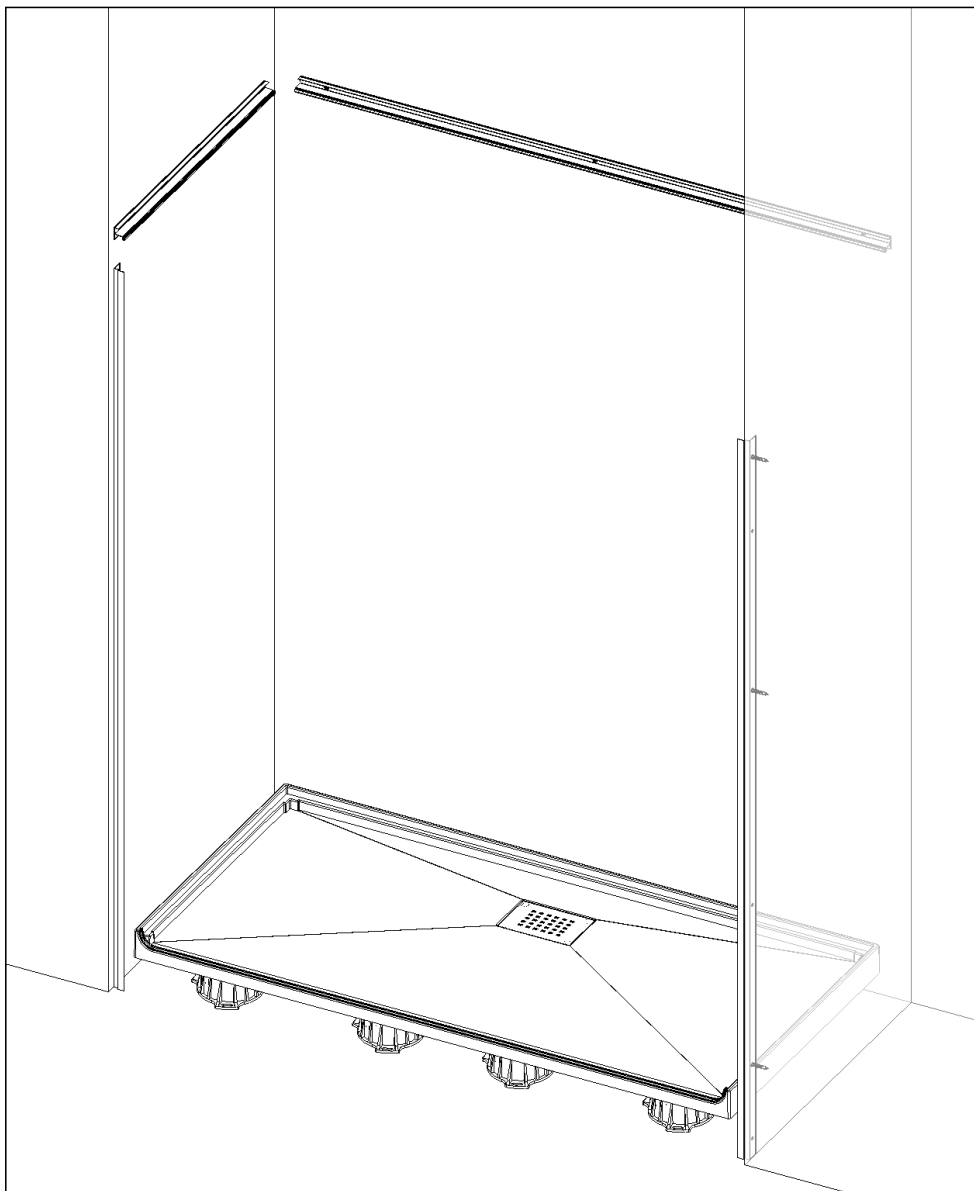

2

2

2A

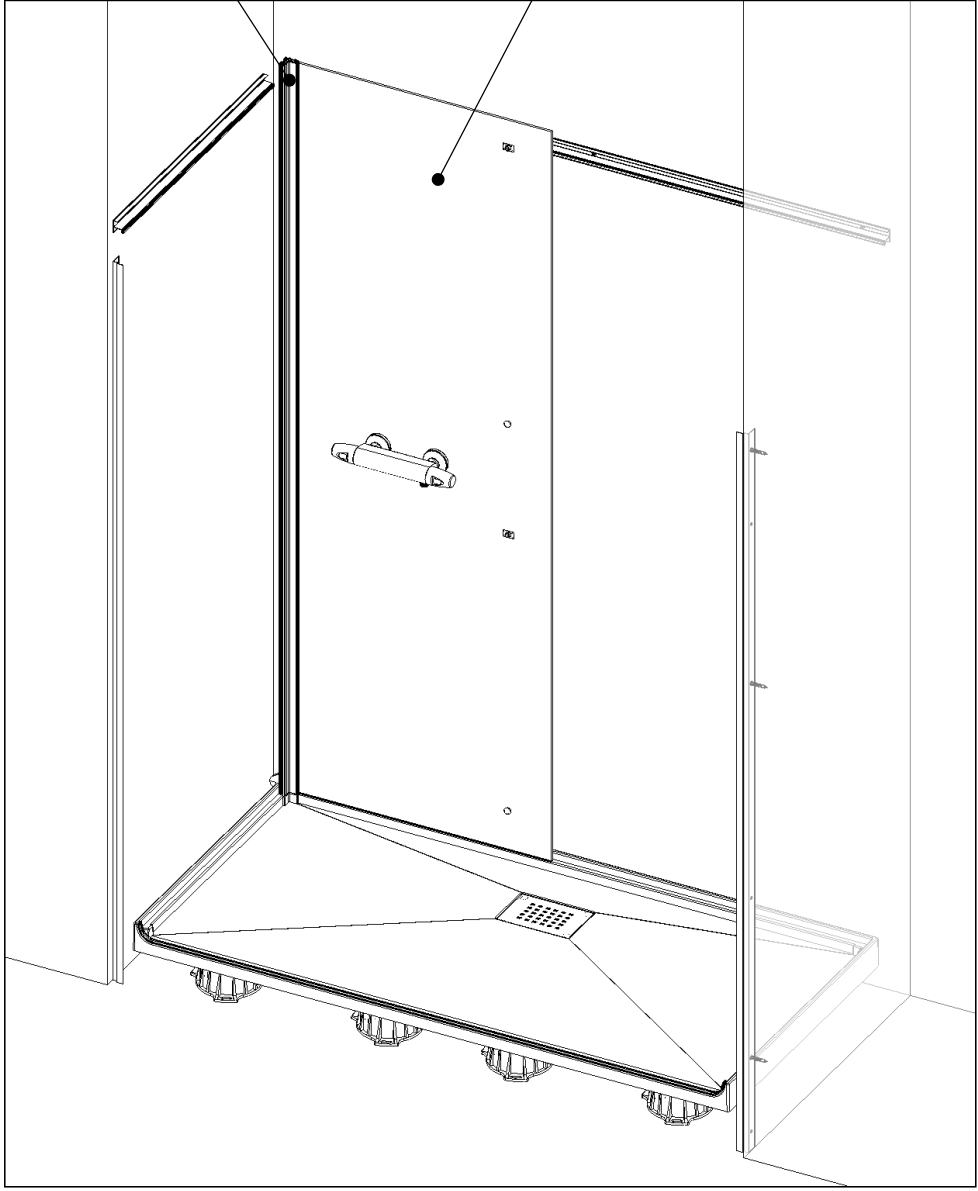

2

2

2B

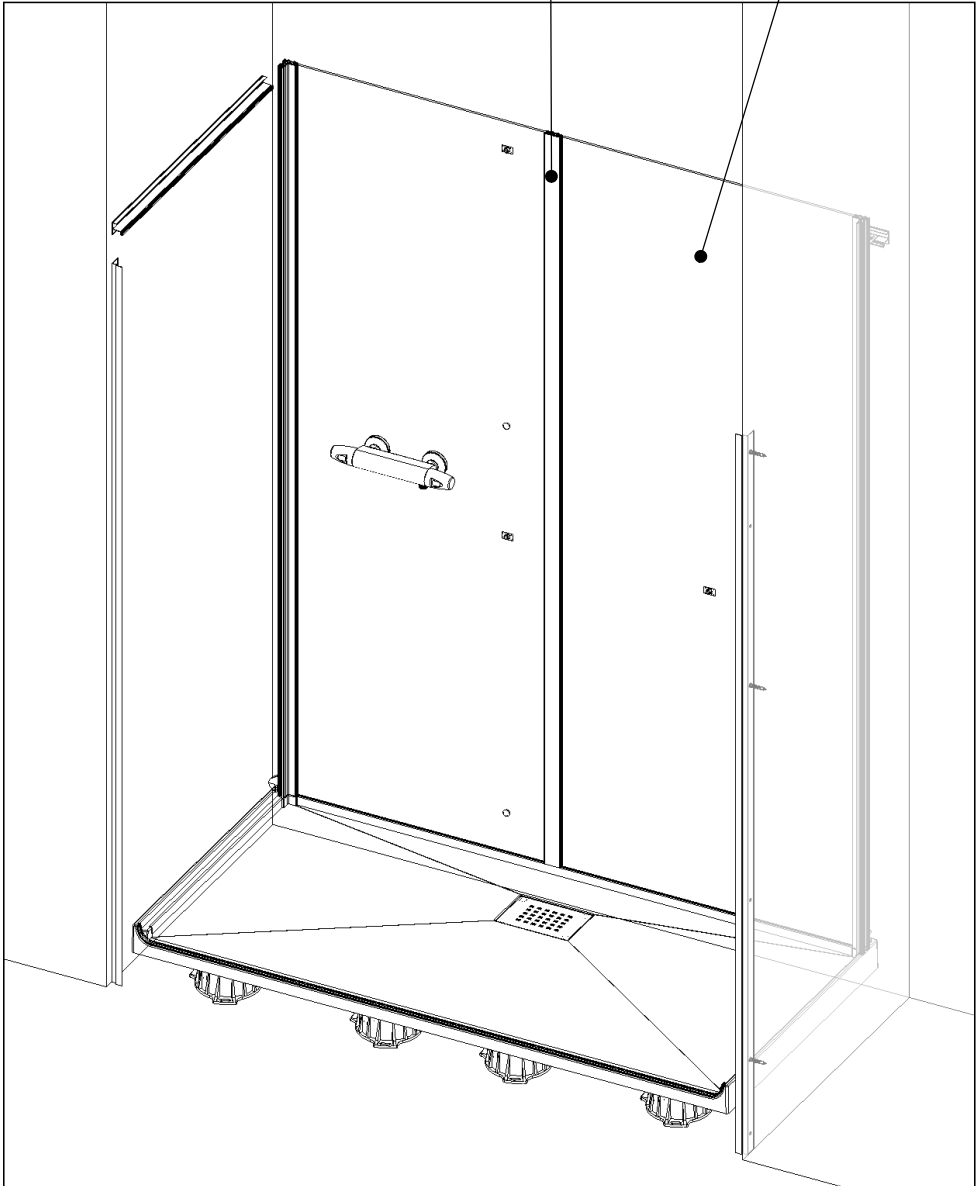

2

2C

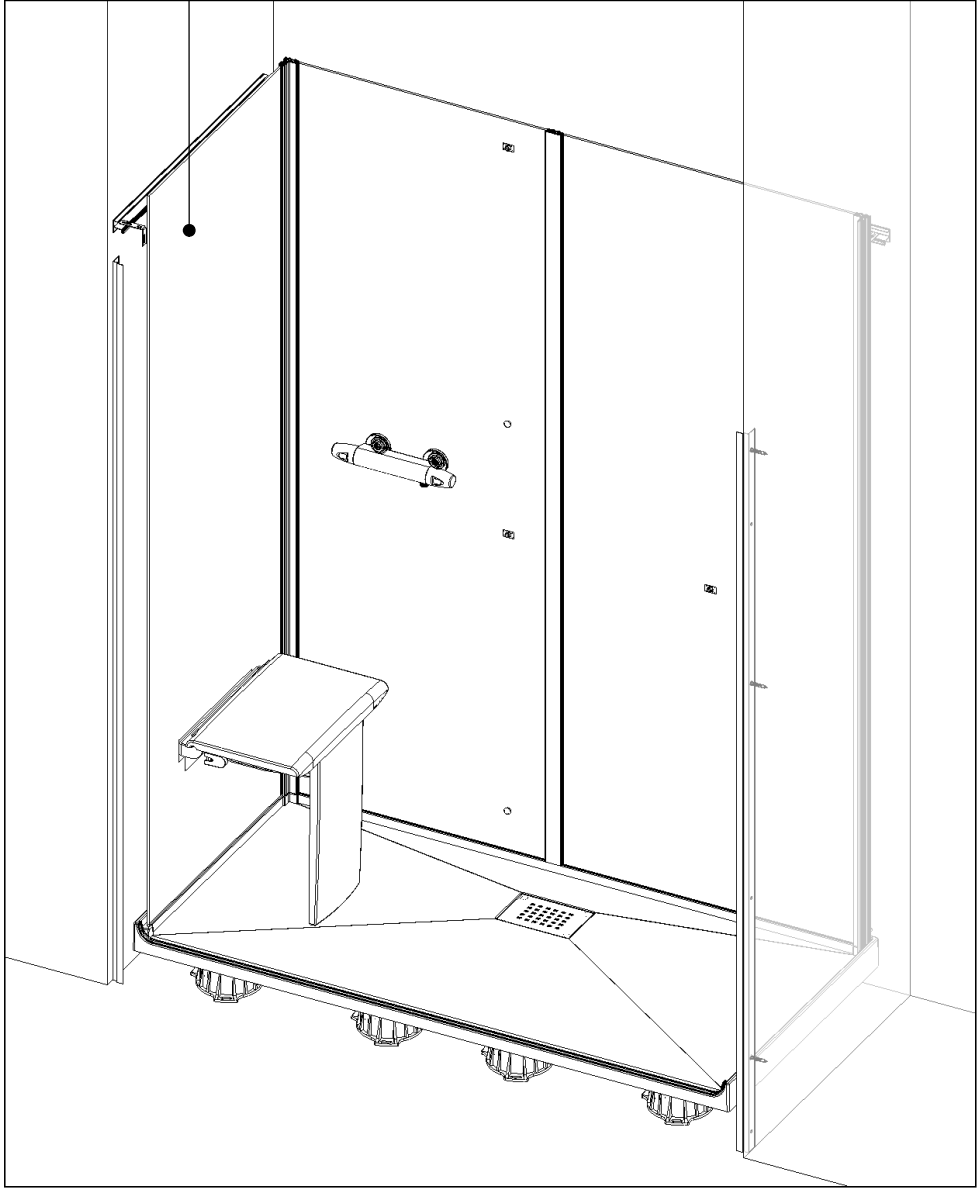

3

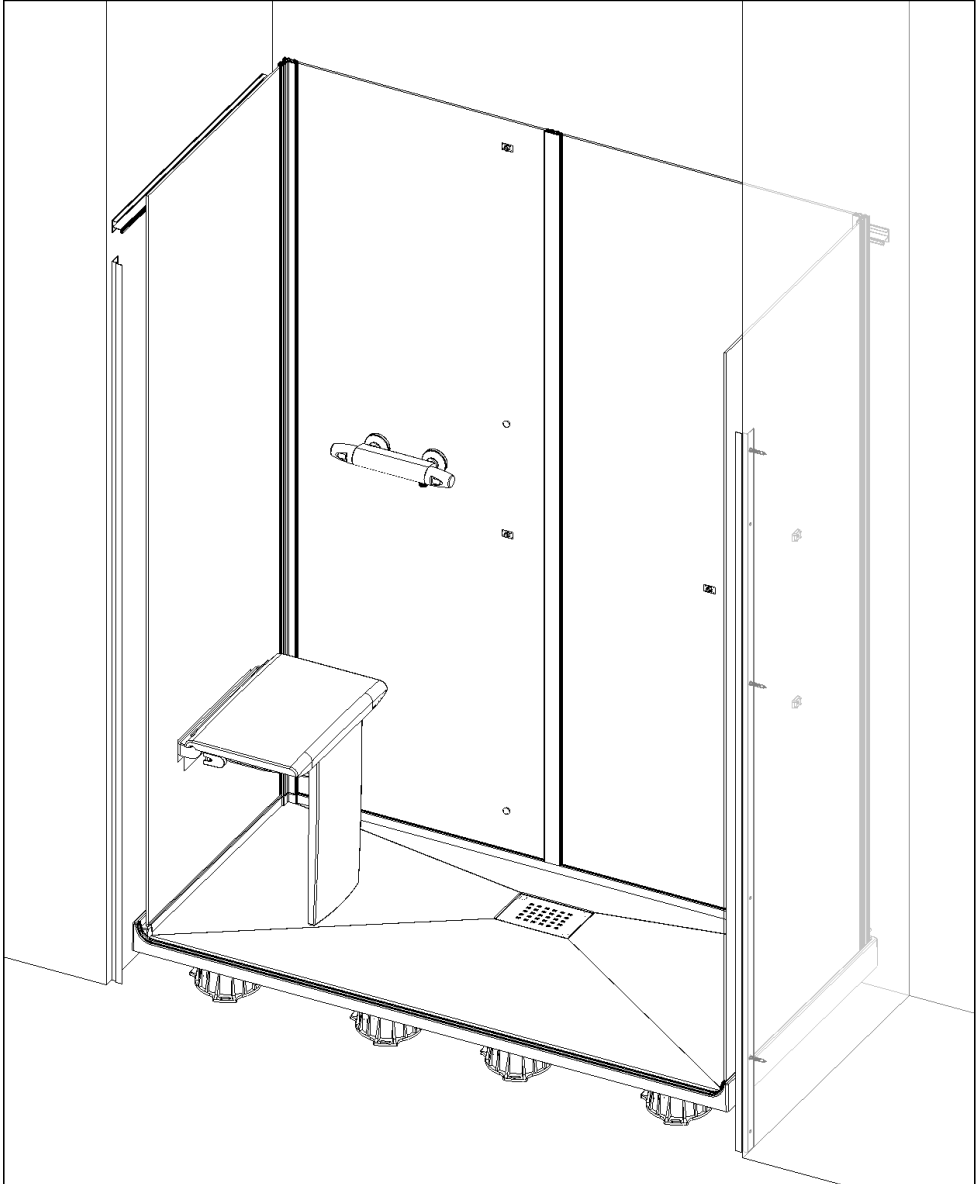

4

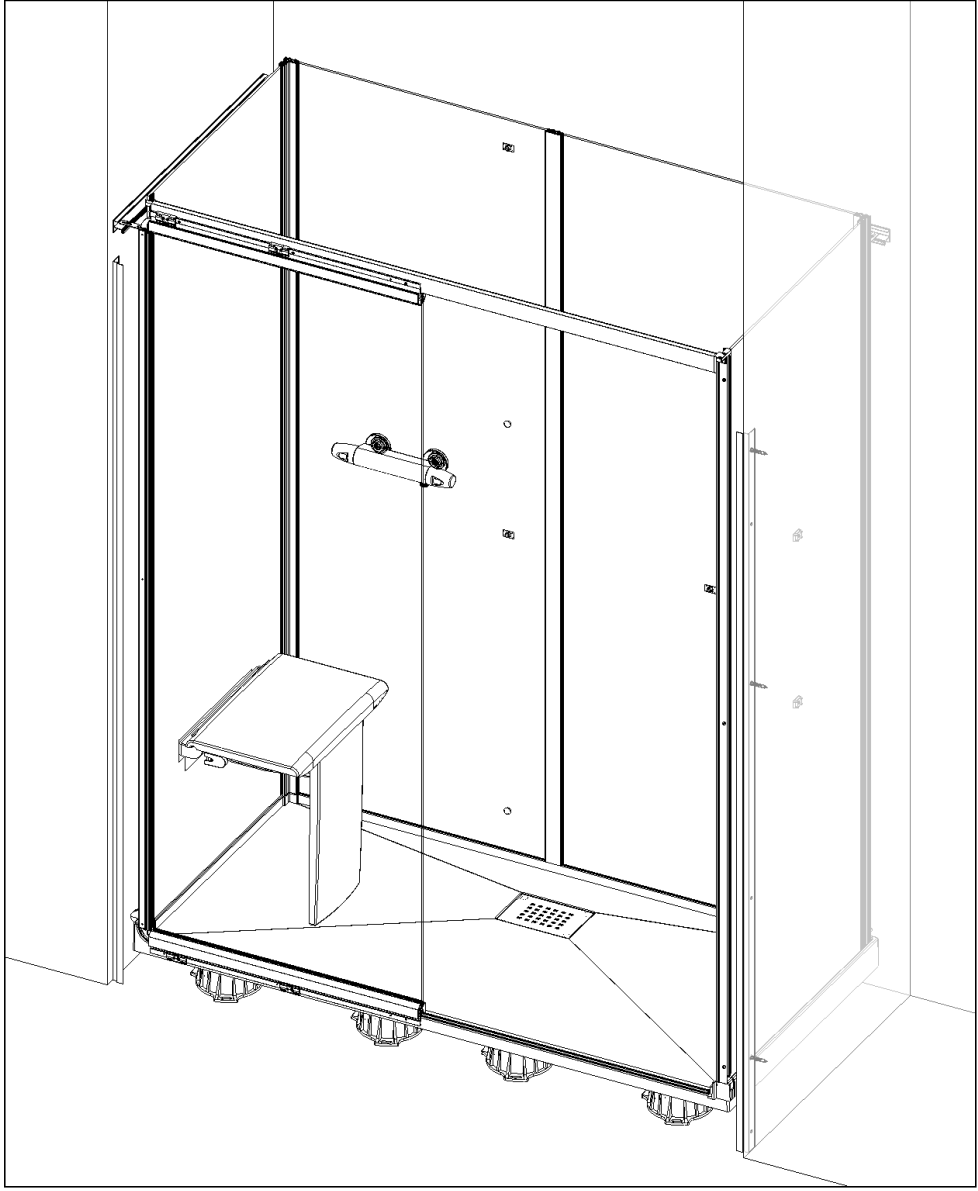

5

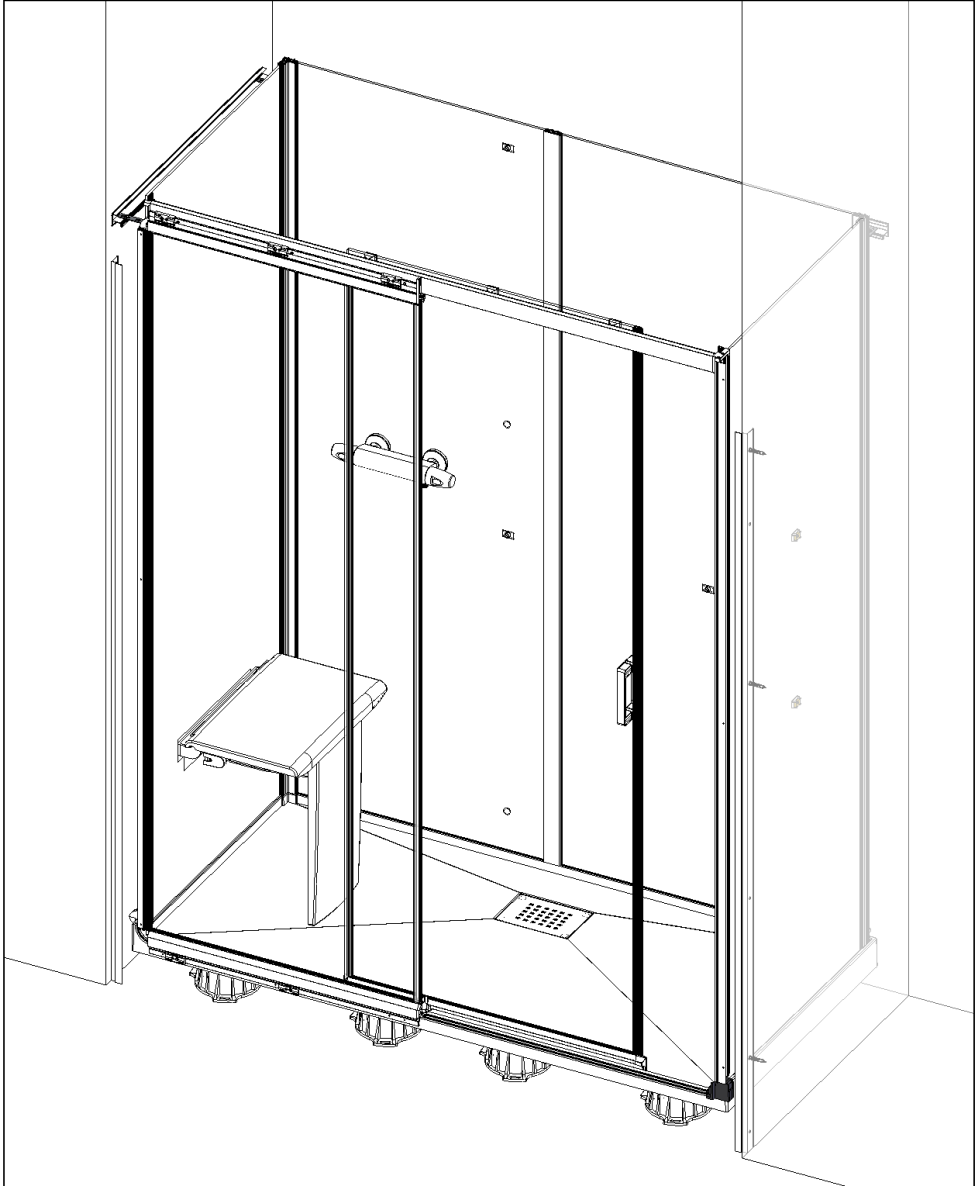

6

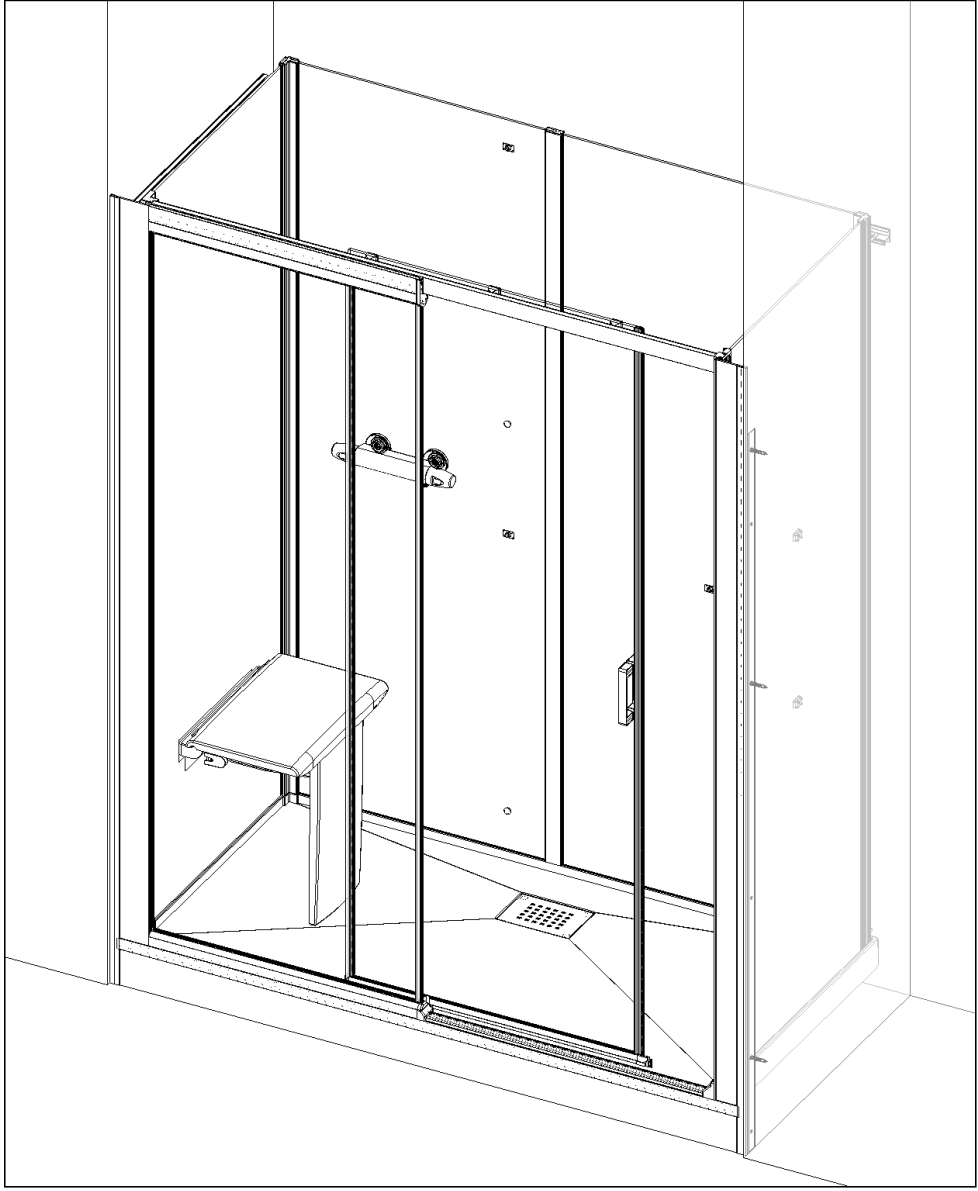

7

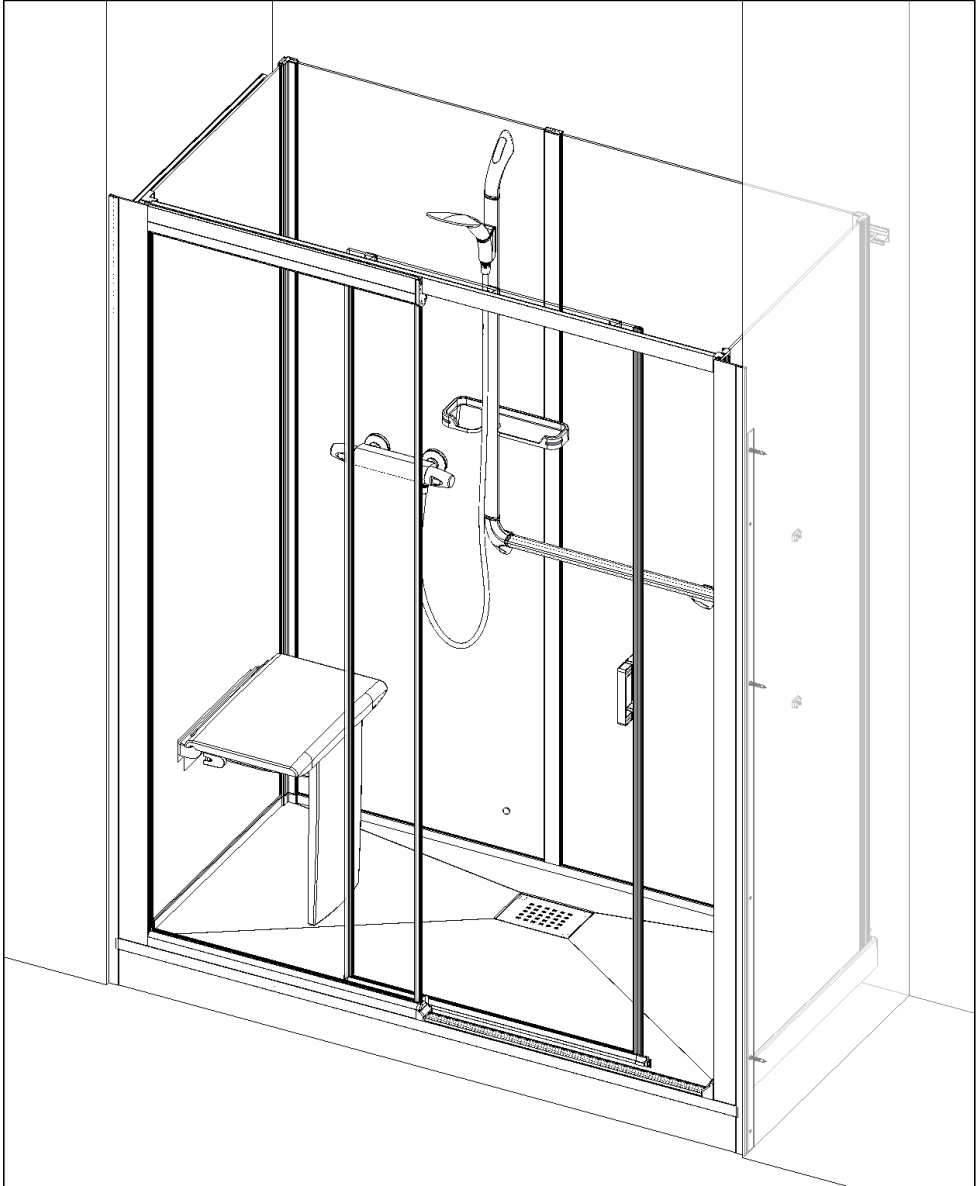

- Zone de décaissement pour un montage de receveur sans pieds
- Area required for the installation of the tray without feet
- Zona rebajada para la instalación del plato sin pies
- Zone necessarie per un montaggio del piatto senza piedi
- Aflooplegebied voor de montage van een douchebak zonder poten
- Freier Raum für Montage der Duschanne ohne FüÙe

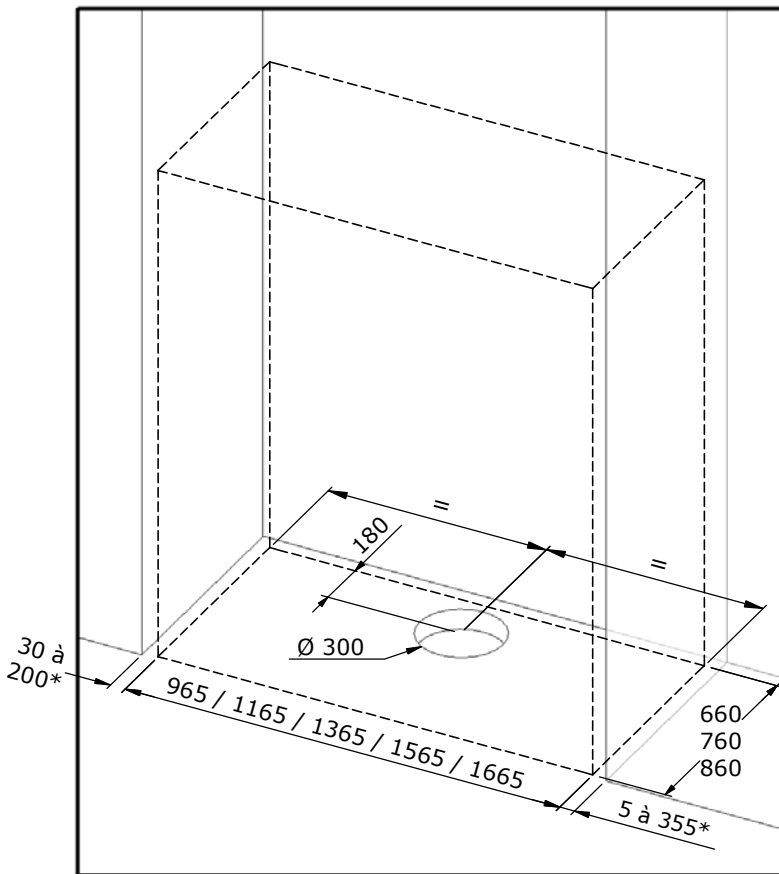

- *● Côté gauche et droit cumulés ne peuvent excéder 385 mm.
- Left and right sides summed must not exceed 385 mm.
- Las cuotas agregadas izquierda y derecha no pueden superar 385 mm.
- Sinistra e destra combinati non possono superare 385 mm.
- De linker- en rechterzijde mogen samen niet groter zijn dan 385 mm.
- Links und rechts dürfen es zusammen nicht mehr als 385 mm sein.

● Cotes en mm ● Dimensions in mm ● Cotas en mm

● Quote in mm ● Afmetingen in mm ● Maße sind in mm angegeben

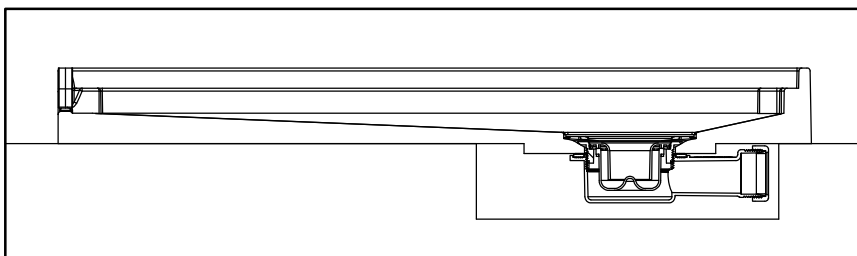



SAV
SERVICE HELPLINES
ASSISTENZA POST-VENDITA
SERVICIO POSTVENTA

FRANCE

02 40 21 29 45

SCHWEIZ

(01) 748 17 44

UK

020 8842 0033

ESPANA

93 544 60 76

IRELAND

04697 33102

NEDERLAND

+31 475 487 100

DEUTSCHLAND

+49 (0) 6074 / 30928 0

BELGIE

+31 475 487 100

ITALIA

(0382) 6181

BELGIQUE

+31 475 487 100

OSTEREICH

+43 1 710 60 70

РОССИЯ

963 19 40, 773 67 22