

Notre service technique est  
à votre écoute aux numéros  
qui sont au dos de cette  
notice d'installation

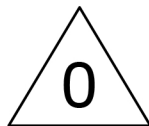

Ⓕ Position de la cabine Ⓖ Position of the shower cubicle  
 Ⓖ Posición de la cabina de ducha Ⓕ Posizione della cabina doccia  
 Ⓖ Positie van de douchecabine Ⓕ Position der Duschkabine

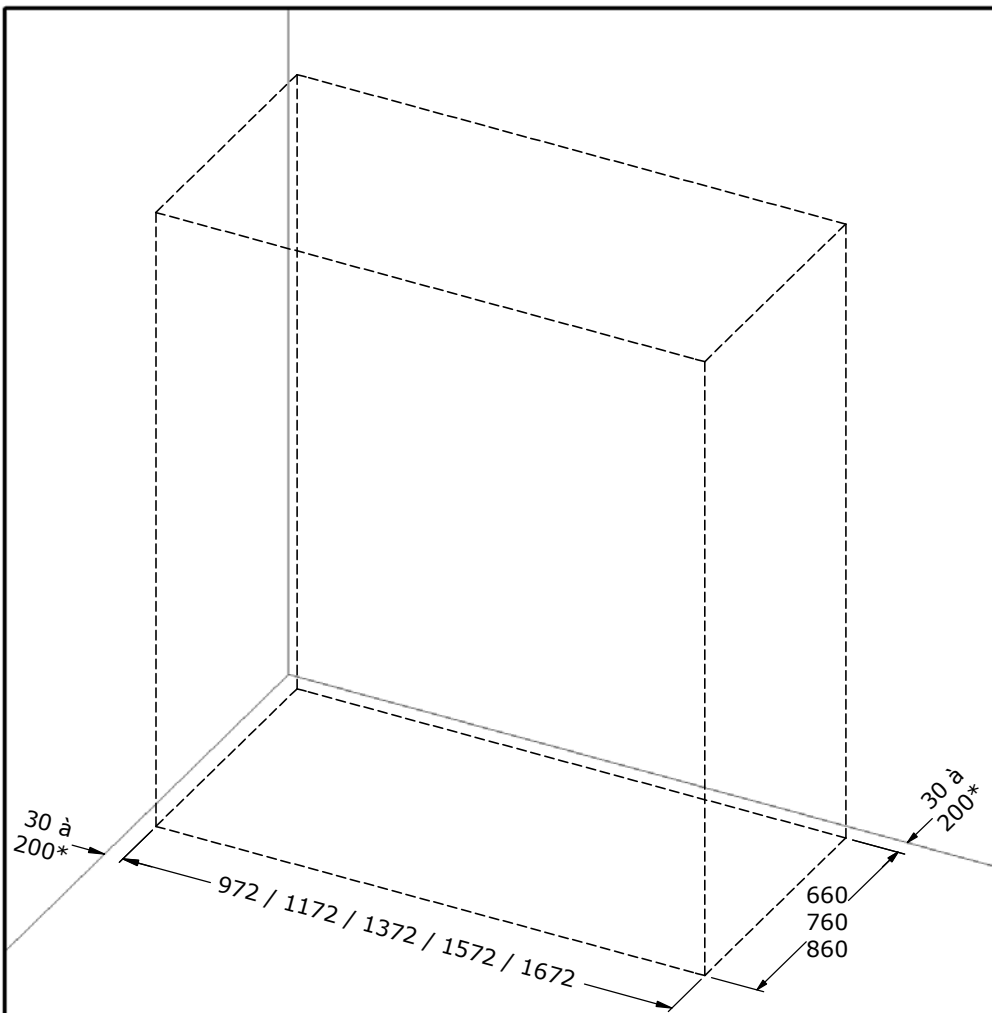

Ⓕ Cotes en mm Ⓖ Dimensions in mm Ⓖ Cotas en mm  
 Ⓕ Quote in mm Ⓖ Afmetingen in mm Ⓕ Maße sind in mm angegeben

\* Ⓕ Côté gauche et droit cumulés ne peuvent excéder 385 mm.

Ⓖ Left and right sides summed must not exceed 385 mm.

Ⓖ Las cuotas agregadas izquierda y derecha no pueden superar 385 mm.

Ⓕ Sinistra e destra combinati non possono superare 385 mm.

Ⓖ De linker- en rechterzijde mogen samen niet groter zijn dan 385 mm.

Ⓕ Links und rechts dürfen es zusammen nicht mehr als 385 mm sein.



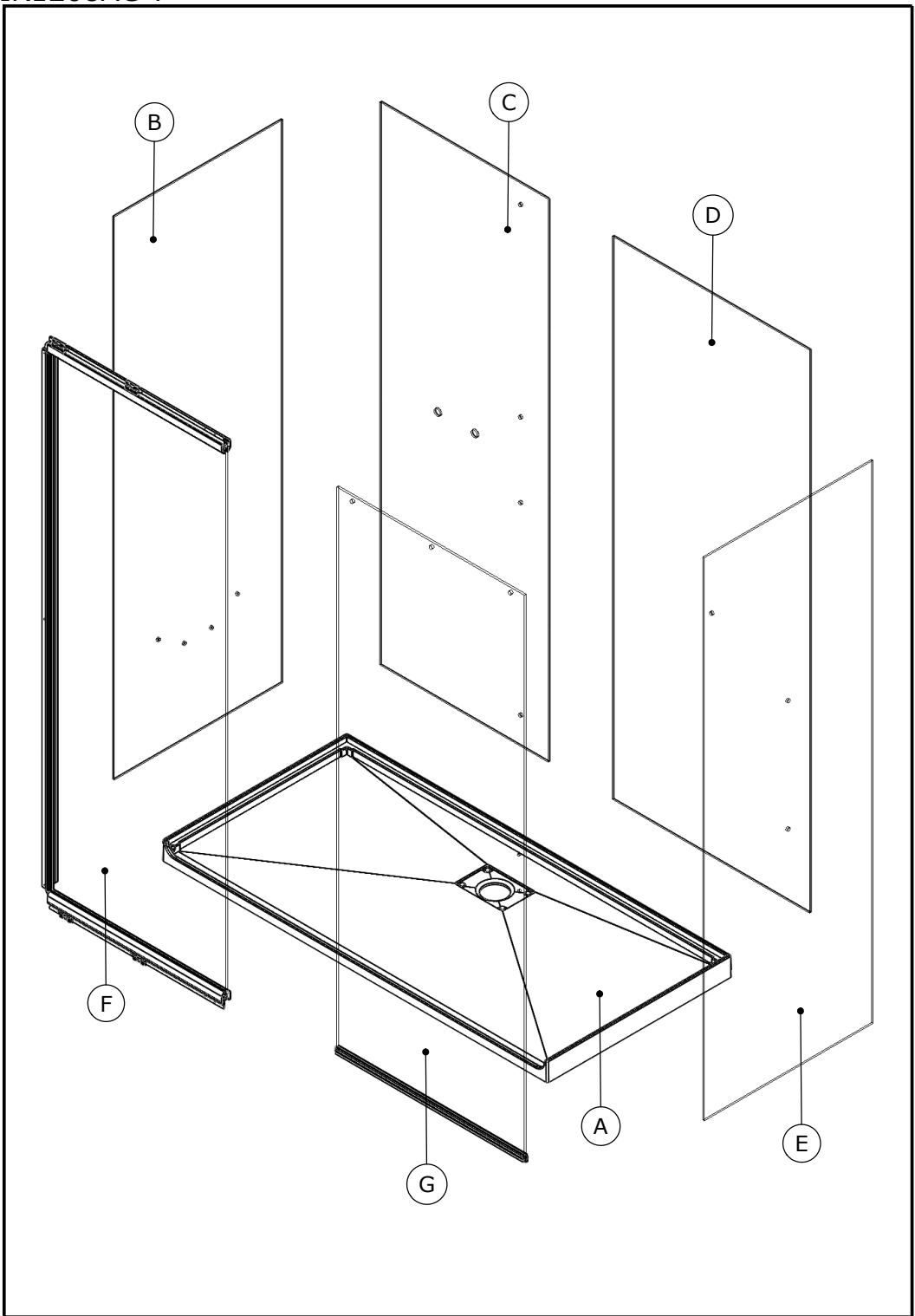

- CODE COLIS (Voir repères en page 4)
- PACKAGE CODES (See marks on page 4)
- REF. BULTOS (Ver pg. 4 para listado de bultos)
- CODE SET (zie blz. 4)
- Codering verpakking (zie omschrijving op pagina 4)
- PAKETCODES (siehe Kennzeichnungen auf Seite 4)

REP	VERSION	100 x 70	100 x 80	100 x 90	120 x 70	120 x 80	120 x 90	140 x 70	140 x 80	140 x 90	160 x 70	160 x 80	160 x 90	170 x 70	170 x 80	170 x 90	
A		RECS61	RECS62	RECS63	RECS64	RECS65	RECS66	RECS67	RECS68	RECS69	RECS70	RECS71	RECS72	RECS73	RECS74	RECS75	
B		C11444E	C11445E	C11446E	C11444E	C11445E	C11446E	C11444E	C11445E	C11446E	C11444E	C11445E	C11446E	C11444E	C11445E	C11446E	
C		C11439E				C11431E											
D						C11440E			C11441E			C11442E			C11443E		
E	SER	C11363E	C11364E	C11365E	C11363E	C11364E	C11365E	C11363E	C11364E	C11365E	C11363E	C11364E	C11365E	C11363E	C11364E	C11365E	
	TN	C11357E	C11358E	C11359E	C11357E	C11358E	C11359E	C11357E	C11358E	C11359E	C11357E	C11358E	C11359E	C11357E	C11358E	C11359E	
F	SER	C11374E			C11375E			C11376E			C11377E			C11378E			
	TN	C11369E			C11370E			C11371E			C11372E			C11373E			
G	SER	C11394E			C11395E			C11396E			C11397E			C11398E			
	TN	C11389E			C11390E			C11391E			C11392E			C11393E			

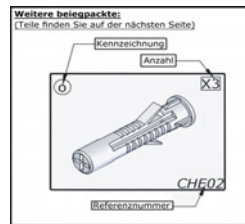
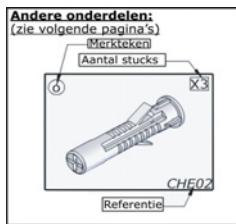
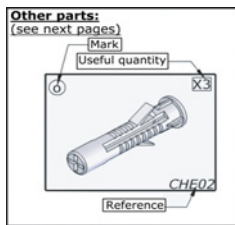
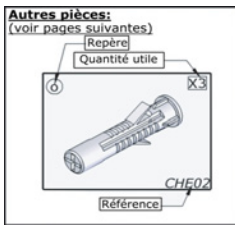

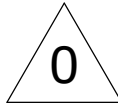

<p><b>SK</b></p> <ul style="list-style-type: none"> <li>● Montage gauche ● Left hand</li> <li>● Montaje a la izquierda</li> <li>● Montaggio a sinistra</li> <li>● Montage links ● Montage links</li> </ul> <p>x1</p> <p><b>SUP172</b></p>	<p><b>SL</b></p> <ul style="list-style-type: none"> <li>● Montage droite ● Right hand</li> <li>● Montaje a la derecha</li> <li>● Montaggio a destra</li> <li>● Montage rechts ● Montage rechts</li> </ul> <p>x1</p> <p><b>SUP173</b></p>	<p><b>PS</b></p> <p>x2</p> <p><b>PPL1116</b></p>
<p><b>SC</b></p> <ul style="list-style-type: none"> <li>● Montage gauche ● Left hand</li> <li>● Montaje a la izquierda</li> <li>● Montaggio a sinistra</li> <li>● Montage links ● Montage links</li> </ul> <p>x1</p> <p><b>SUP164</b></p>	<p><b>SD</b></p> <ul style="list-style-type: none"> <li>● Montage droite ● Right hand</li> <li>● Montaje a la derecha</li> <li>● Montaggio a destra</li> <li>● Montage rechts ● Montage rechts</li> </ul> <p>x1</p> <p><b>SUP165</b></p>	<p><b>PT</b></p> <p>120/140/160/170 x1</p> <p>100 x0</p> <p><b>PPL1117</b></p>
<p><b>PG</b></p> <ul style="list-style-type: none"> <li>● Montage gauche ● Left hand</li> <li>● Montaje a la izquierda</li> <li>● Montaggio a sinistra</li> <li>● Montage links ● Montage links</li> </ul> <p>x1</p> <p><b>PPL1102</b></p>	<p><b>PH</b></p> <ul style="list-style-type: none"> <li>● Montage droite ● Right hand</li> <li>● Montaje a la derecha</li> <li>● Montaggio a destra</li> <li>● Montage rechts ● Montage rechts</li> </ul> <p>x1</p> <p><b>PPL1103</b></p>	<p><b>PU</b></p> <p>x1</p> <p><b>PPL1118</b></p>
<p><b>PAB</b></p> <ul style="list-style-type: none"> <li>● Montage gauche ● Left hand</li> <li>● Montaje a la izquierda</li> <li>● Montaggio a sinistra</li> <li>● Montage links ● Montage links</li> </ul> <p>x1</p> <p><b>PPL1134</b></p>	<p><b>PAC</b></p> <ul style="list-style-type: none"> <li>● Montage droite ● Right hand</li> <li>● Montaje a la derecha</li> <li>● Montaggio a destra</li> <li>● Montage rechts ● Montage rechts</li> </ul> <p>x1</p> <p><b>PPL1135</b></p>	<p><b>MA</b></p> <p>x1</p> <p><b>MIT100</b></p>
<p><b>PAX</b></p> <p>x4</p> <p><b>PPL1318</b></p>	<p><b>VG</b></p> <p>x2</p> <p><b>SET03</b></p>	<p><b>MB</b></p> <p>x1</p> <p><b>MIT94</b></p>

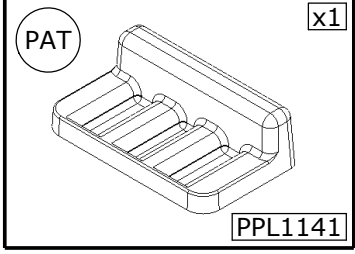
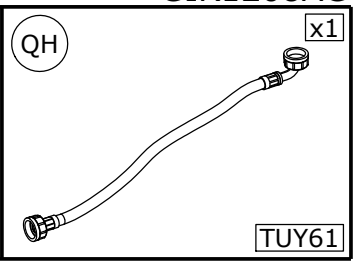
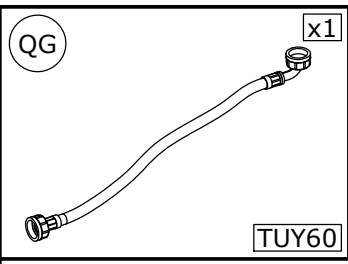
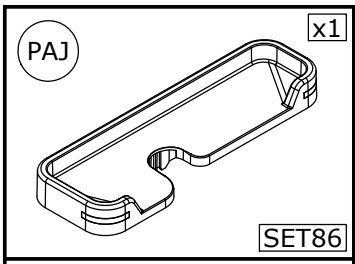

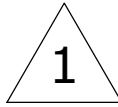

<p>PA 120/140/160/170 x11 100 x9</p> <p>PPL802</p>	<p>PB 120/140/160/170 x11 100 x9</p> <p>PPL804</p>	<p>QA x1</p> <p>BOND28</p>													
<p>TA x1</p> <p>TOL11</p>	<p>VN Ø4 x11</p> <p>45</p> <p>1=1 VIS231</p>														
<p>VA x11</p> <p>CHE02</p>	<p>VV x11</p> <p>RON34</p>	<p>AU x2</p> <p>Lg=1940mm 6210-01</p>													
<p>AA x1</p> <p>Lg=1972mm 6189-01</p>	<p>AS x1</p> <table border="1"> <thead> <tr> <th colspan="2">6209</th> </tr> <tr> <th>● Longueur ● Length ● Largo</th> <th>● Lunghezza ● Lengte ● Länge</th> </tr> </thead> <tbody> <tr> <td>100</td> <td>Lg=950mm</td> </tr> <tr> <td>120</td> <td>Lg=1150mm</td> </tr> <tr> <td>140</td> <td>Lg=1350mm</td> </tr> <tr> <td>160</td> <td>Lg=1550mm</td> </tr> <tr> <td>170</td> <td>Lg=1650mm</td> </tr> </tbody> </table>	6209		● Longueur ● Length ● Largo	● Lunghezza ● Lengte ● Länge	100	Lg=950mm	120	Lg=1150mm	140	Lg=1350mm	160	Lg=1550mm	170	Lg=1650mm
6209															
● Longueur ● Length ● Largo	● Lunghezza ● Lengte ● Länge														
100	Lg=950mm														
120	Lg=1150mm														
140	Lg=1350mm														
160	Lg=1550mm														
170	Lg=1650mm														
<p>AB 120/140/160/170 x1 100 x0</p> <p>Lg=1972mm 6190-01</p>	<p>AT x1</p> <table border="1"> <thead> <tr> <th colspan="2">6209</th> </tr> <tr> <th>● Largeur ● Width ● Ancho</th> <th>● Larghezza ● Breedte ● Breite</th> </tr> </thead> <tbody> <tr> <td>70</td> <td>Lg=635mm</td> </tr> <tr> <td>80</td> <td>Lg=735mm</td> </tr> <tr> <td>90</td> <td>Lg=835mm</td> </tr> </tbody> </table>	6209		● Largeur ● Width ● Ancho	● Larghezza ● Breedte ● Breite	70	Lg=635mm	80	Lg=735mm	90	Lg=835mm				
6209															
● Largeur ● Width ● Ancho	● Larghezza ● Breedte ● Breite														
70	Lg=635mm														
80	Lg=735mm														
90	Lg=835mm														

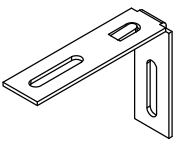
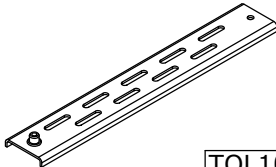
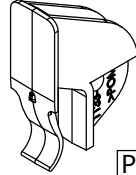
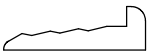
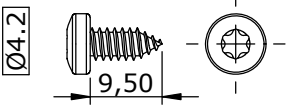
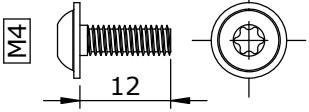
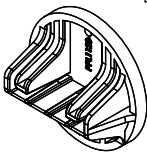
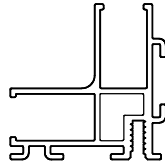
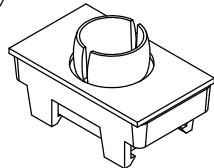
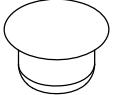

2

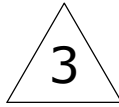
<p>TE <span style="border: 1px solid black; padding: 2px;">120/140/160/170</span> <span style="border: 1px solid black; padding: 2px;">x6</span> <span style="border: 1px solid black; padding: 2px;">100</span> <span style="border: 1px solid black; padding: 2px;">x4</span></p>  <p>TOL102</p>	<p>TF <span style="border: 1px solid black; padding: 2px;">120/140/160/170</span> <span style="border: 1px solid black; padding: 2px;">x6</span> <span style="border: 1px solid black; padding: 2px;">100</span> <span style="border: 1px solid black; padding: 2px;">x4</span></p>  <p>TOL103</p>	<p>PAA <span style="border: 1px solid black; padding: 2px;">120/140/160/170</span> <span style="border: 1px solid black; padding: 2px;">x4</span> <span style="border: 1px solid black; padding: 2px;">100</span> <span style="border: 1px solid black; padding: 2px;">x3</span></p>  <p>PPL1133</p>
<p>JG <span style="border: 1px solid black; padding: 2px;">120/140/160/170</span> <span style="border: 1px solid black; padding: 2px;">x6</span> <span style="border: 1px solid black; padding: 2px;">100</span> <span style="border: 1px solid black; padding: 2px;">x4</span></p>  <p>Lg=1971mm</p> <p>P101</p>	<p>VQ <span style="border: 1px solid black; padding: 2px;">120/140/160/170</span> <span style="border: 1px solid black; padding: 2px;">x5</span> <span style="border: 1px solid black; padding: 2px;">100</span> <span style="border: 1px solid black; padding: 2px;">x4</span></p>  <p>Ø4.2 9,50</p> <p>1=1</p> <p>VIS238</p>	<p>VR <span style="border: 1px solid black; padding: 2px;">120/140/160/170</span> <span style="border: 1px solid black; padding: 2px;">x6</span> <span style="border: 1px solid black; padding: 2px;">100</span> <span style="border: 1px solid black; padding: 2px;">x4</span></p>  <p>M4 12</p> <p>1=1</p> <p>VIS239</p>
<p>PAL <span style="border: 1px solid black; padding: 2px;">120/140/160/170</span> <span style="border: 1px solid black; padding: 2px;">x1</span> <span style="border: 1px solid black; padding: 2px;">100</span> <span style="border: 1px solid black; padding: 2px;">x0</span></p>  <p>PPL1128</p>	<p>AA <span style="border: 1px solid black; padding: 2px;">x1</span></p>  <p>Lg=1972mm</p> <p>6189-01</p>	<p>VD <span style="border: 1px solid black; padding: 2px;">x3</span></p>  <p>SET88</p>
<p>QB <span style="border: 1px solid black; padding: 2px;">120/140/160/170</span> <span style="border: 1px solid black; padding: 2px;">x2</span> <span style="border: 1px solid black; padding: 2px;">100</span> <span style="border: 1px solid black; padding: 2px;">x3</span></p>  <p>BOU40</p>		

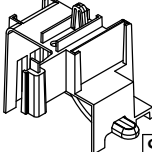
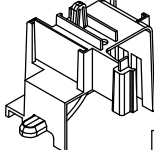
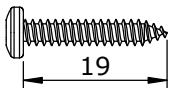
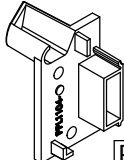
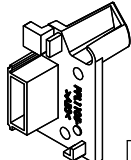
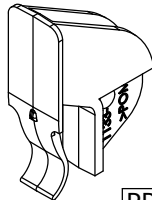
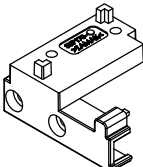
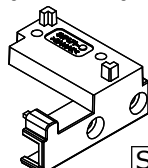

<p>(VQ)    Ø4.2    x3</p> <p>1=1    VIS238</p>	<p>(JG)    x1</p> <p>Lg=1971mm    P101</p>	<p>(AC)    x1</p> <p>Lg=1944mm    6192-01</p>										
<p>(AP)    x1</p> <p>Lg=1952mm    6205-01</p>	<p>(AI)    x1</p> <table border="1" style="margin-left: auto; margin-right: auto; border-collapse: collapse;"> <thead> <tr> <th colspan="2" style="text-align: center;">6198</th> </tr> <tr> <th style="text-align: center;">● Largeur ● Width ● Ancho</th> <th style="text-align: center;">● Larghezza ● Breedte ● Breite</th> </tr> </thead> <tbody> <tr> <td style="text-align: center;">70</td> <td style="text-align: center;">Lg=567mm</td> </tr> <tr> <td style="text-align: center;">80</td> <td style="text-align: center;">Lg=667mm</td> </tr> <tr> <td style="text-align: center;">90</td> <td style="text-align: center;">Lg=767mm</td> </tr> </tbody> </table>		6198		● Largeur ● Width ● Ancho	● Larghezza ● Breedte ● Breite	70	Lg=567mm	80	Lg=667mm	90	Lg=767mm
6198												
● Largeur ● Width ● Ancho	● Larghezza ● Breedte ● Breite											
70	Lg=567mm											
80	Lg=667mm											
90	Lg=767mm											

4

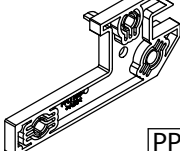
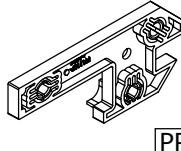
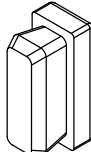
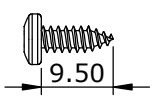
<p><b>SA</b></p> <ul style="list-style-type: none"> <li>● Montage gauche ● Left hand</li> <li>● Montaje a la izquierda</li> <li>● Montaggio a sinistra</li> <li>● Montage links ● Montage links</li> </ul>  <p><b>SET107</b></p> <p><b>x1</b></p>	<p><b>SB</b></p> <ul style="list-style-type: none"> <li>● Montage droite ● Right hand</li> <li>● Montaje a la derecha</li> <li>● Montaggio a destra</li> <li>● Montage rechts ● Montage rechts</li> </ul>  <p><b>SET108</b></p> <p><b>x1</b></p>	<p><b>VM</b></p> <p><math>\varnothing 3.5</math></p>  <p>19</p> <p><b>1=1</b></p> <p><b>VIS215</b></p> <p><b>x8</b></p>	
<p><b>PI</b></p> <ul style="list-style-type: none"> <li>● Montage gauche ● Left hand</li> <li>● Montaje a la izquierda</li> <li>● Montaggio a sinistra</li> <li>● Montage links ● Montage links</li> </ul>  <p><b>PPL1104</b></p> <p><b>x1</b></p>	<p><b>PJ</b></p> <ul style="list-style-type: none"> <li>● Montage droite ● Right hand</li> <li>● Montaje a la derecha</li> <li>● Montaggio a destra</li> <li>● Montage rechts ● Montage rechts</li> </ul>  <p><b>PPL1105</b></p> <p><b>x1</b></p>	<p><b>PAA</b></p>  <p><b>PPL1133</b></p> <p><b>x1</b></p>	
<p><b>SI</b></p> <ul style="list-style-type: none"> <li>● Montage gauche ● Left hand</li> <li>● Montaje a la izquierda</li> <li>● Montaggio a sinistra</li> <li>● Montage links ● Montage links</li> </ul>  <p><b>SUP170</b></p> <p><b>x1</b></p>	<p><b>SJ</b></p> <ul style="list-style-type: none"> <li>● Montage droite ● Right hand</li> <li>● Montaje a la derecha</li> <li>● Montaggio a destra</li> <li>● Montage rechts ● Montage rechts</li> </ul>  <p><b>SUP171</b></p> <p><b>x1</b></p>	<p><b>JG</b></p>  <p><b>Lg=1971mm</b></p> <p><b>P101</b></p> <p><b>x1</b></p>	
<p><b>PK</b></p> <ul style="list-style-type: none"> <li>● Montage gauche ● Left hand</li> <li>● Montaje a la izquierda</li> <li>● Montaggio a sinistra</li> <li>● Montage links ● Montage links</li> </ul>  <p><b>PPL1106</b></p> <p><b>x1</b></p>	<p><b>PL</b></p> <ul style="list-style-type: none"> <li>● Montage droite ● Right hand</li> <li>● Montaje a la derecha</li> <li>● Montaggio a destra</li> <li>● Montage rechts ● Montage rechts</li> </ul>  <p><b>PPL1107</b></p> <p><b>x1</b></p>	<p><b>QC</b></p>  <p><b>BUT22</b></p> <p><b>x1</b></p>	
<p><b>VP</b></p> <p><math>\varnothing 3.5</math></p>  <p>9.50</p> <p><b>1=1</b></p> <p><b>VIS237</b></p> <p><b>x3</b></p>			

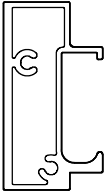
(AG)  x1

6196		
● Longueur	● Length	● Largo
● Lunghezza	● Lengte	● Länge
100		Lg=880mm
120		Lg=1080mm
140		Lg=1280mm
160		Lg=1480mm
170		Lg=1580mm

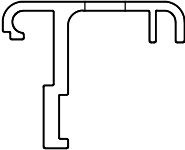
(AD)  x1

6194		
● Longueur	● Length	● Largo
● Lunghezza	● Lengte	● Länge
100		Lg=456mm
120		Lg=556mm
140		Lg=656mm
160		Lg=756mm
170		Lg=806mm

(AJ)  x1

6199		
● Longueur	● Length	● Largo
● Lunghezza	● Lengte	● Länge
100		Lg=401mm
120		Lg=501mm
140		Lg=601mm
160		Lg=701mm
170		Lg=751mm

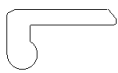
(AQ)  x2

Lg=300mm 6206-01

5

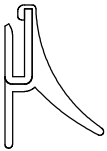
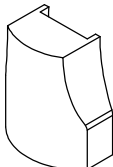
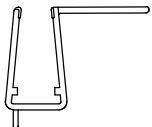
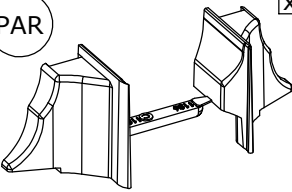
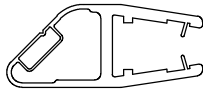
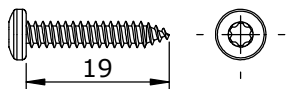
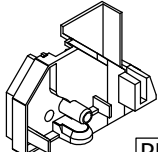
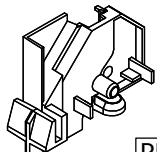
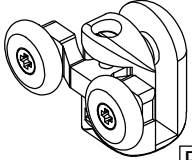
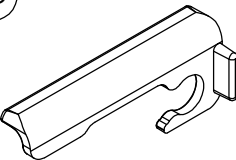
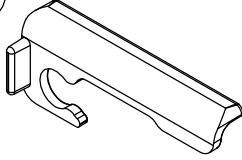
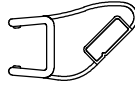
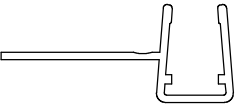
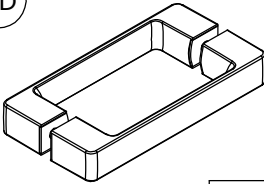
<p>JE <span style="float: right;">x1</span></p>  <p>Lg=820mm <span style="float: right;">JOI239</span></p>	<p>PC <span style="float: right;">x1</span></p>  <p><span style="float: right;">PPL823</span></p>	<p>JC <span style="float: right;">x1</span></p>  <p>Lg=1882mm <span style="float: right;">J723</span></p>
<p>PAR <span style="float: right;">x1</span></p>  <p><span style="float: right;">PPL1136/1137</span></p>	<p>JB <span style="float: right;">x1</span></p>  <p>Lg=1959mm <span style="float: right;">AI150</span></p>	<p>VM <span style="float: right;">Ø3.5</span> <span style="float: right;">x1</span></p>  <p><span style="float: right;">1=1</span> <span style="float: right;">VIS215</span></p>
<p>PO <span style="float: right;">x1</span></p> <ul style="list-style-type: none"> <li>● Montage gauche ● Left hand</li> <li>● Montaje a la izquierda</li> <li>● Montaggio a sinistra</li> <li>● Montage links ● Montage links</li> </ul>  <p><span style="float: right;">PPL1110</span></p>	<p>PP <span style="float: right;">x1</span></p> <ul style="list-style-type: none"> <li>● Montage droite ● Right hand</li> <li>● Montaje a la derecha</li> <li>● Montaggio a destra</li> <li>● Montage rechts ● Montage rechts</li> </ul>  <p><span style="float: right;">PPL1111</span></p>	<p>QE <span style="float: right;">140/160/170</span> <span style="float: right;">x3</span> <span style="float: right;">100/120</span> <span style="float: right;">x2</span></p>  <p><span style="float: right;">ROU37</span></p>
<p>PD <span style="float: right;">x1</span></p>  <p><span style="float: right;">PPL1080</span></p>	<p>PE <span style="float: right;">x1</span></p>  <p><span style="float: right;">PPL1081</span></p>	<p>JA <span style="float: right;">x1</span></p>  <p><span style="float: right;">AIM36</span></p>
<p>JD <span style="float: right;">x1</span></p>  <p>Lg=1894mm <span style="float: right;">J719</span></p>	<p>QD <span style="float: right;">x1</span></p>  <p><span style="float: right;">PGN36</span></p>	

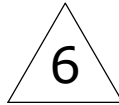

<p>(VQ) <math>\varnothing 4.2</math> x6</p> <p>9.50</p> <p>1=1 VIS238</p>	<p>(PF) 140/160/170 x4 100/120 x3</p> <p>PPL1099</p>	<p>(VO) <math>\varnothing 3.5</math> x12</p> <p>6.50</p> <p>1=1 VIS253</p>
<p>(PAK) 140/160/170 x8 100/120 x6</p> <p>SET105</p>	<p>(VI) x3</p> <p>Lg=2800mm VEL06-5</p>	<p>(VJ) x3</p> <p>Lg=2800mm VEL06-6</p>
<p>(SE) x1</p> <ul style="list-style-type: none"> <li>● Montage gauche ● Left hand</li> <li>● Montaje a la izquierda</li> <li>● Montaggio a sinistra</li> <li>● Montage links ● Montage links</li> </ul> <p>SUP166</p>	<p>(SF) x1</p> <ul style="list-style-type: none"> <li>● Montage droite ● Right hand</li> <li>● Montaje a la derecha</li> <li>● Montaggio a destra</li> <li>● Montage rechts ● Montage rechts</li> </ul> <p>SUP167</p>	<p>(JJ) x2</p> <p>Lg=2200mm PFL84</p>
<p>(PZ) x1</p> <p>PPL1132</p>	<p>(AE) x1</p> <p>Lg=2030mm 6195-01</p>	<p>(AF) x1</p> <p>Lg=1005mm 6195-02</p>
<p>(AH) x2</p> <p>Lg=1998mm 6197-01</p>	<p>(FA) x1</p> <p>2055</p> <p>125</p> <p>PUS132</p>	

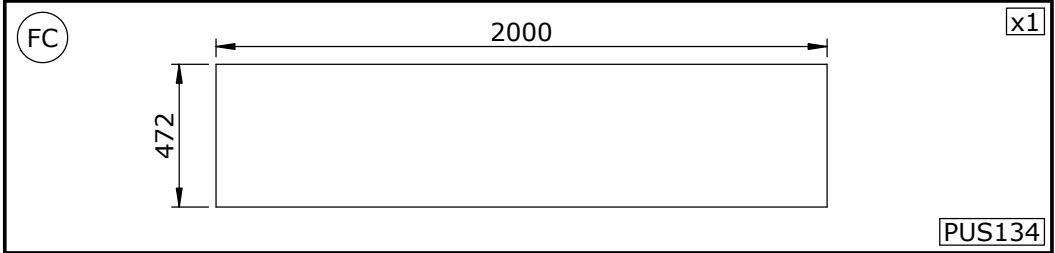
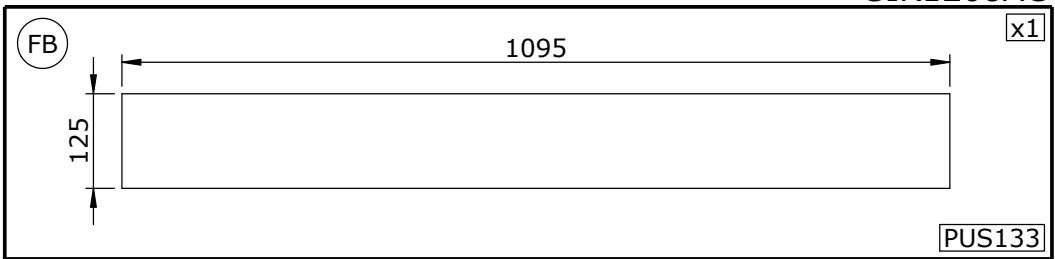

- Les quantités données sont les quantités utiles au montage. les sachets fournis contiennent des pièces supplémentaires.
  - The quantities given are what are required for the installation. There may be some surplus in the package provide.
- Las cantidades indicadas son las cantidades necesarias para el montaje. Las bolsitas incluidas contienen piezas suplementarias.
  - Le quantità fornite sono le quantità necessarie al montaggio. I sacchetti forniti contengono pezzi supplementari.
  - De aangegeven aantallen zijn vereist voor de montage. De verpakking bevat extra onderdelen.
- Die Mengenangaben beziehen sich auf die für die Montage nötigen Teile. Eventuell weitere beige packte Teile ignorieren.

● Outillage nécessaire ● Tools required ● Equipamiento necesario  
 ● Attrezzatura necessaria ● Benodigde gereedschap ● Werkzeuge erforderlich

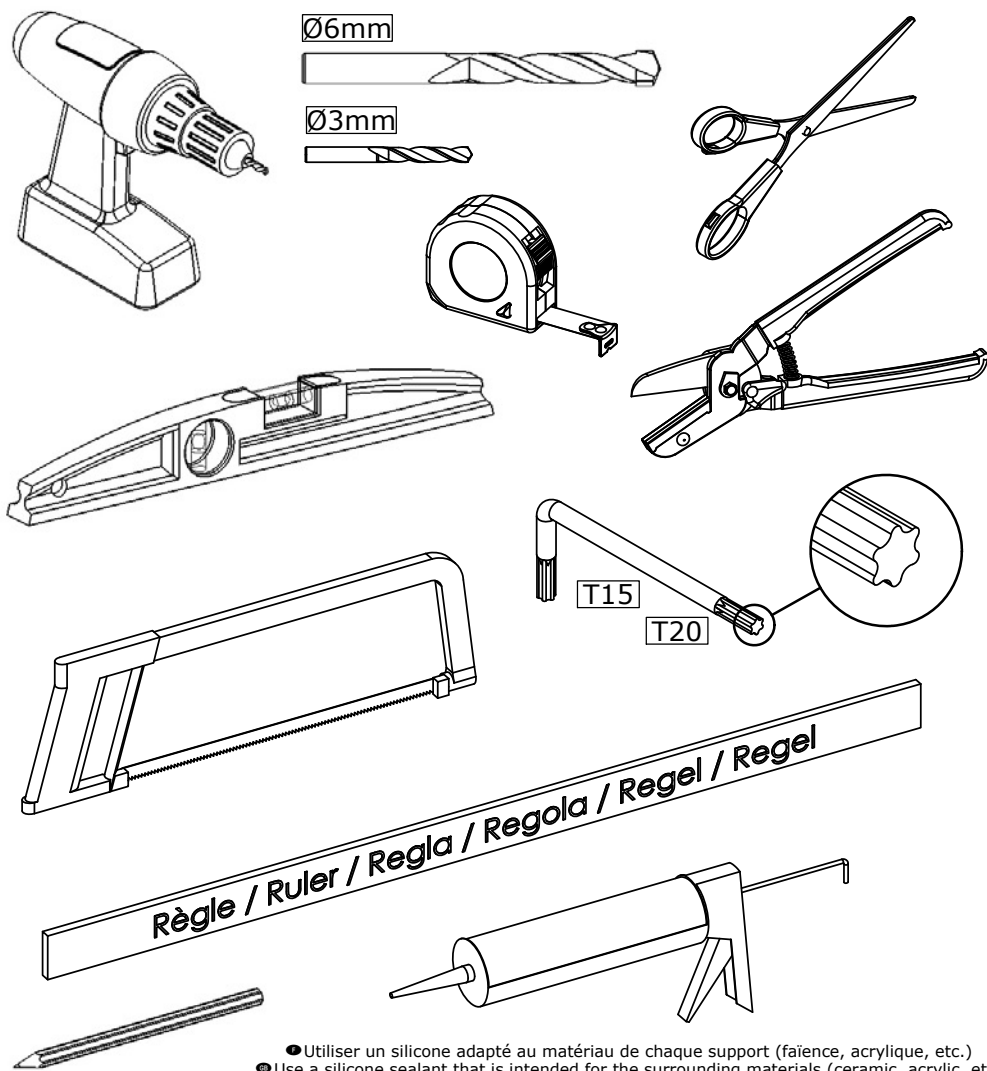

- Utiliser un silicone adapté au matériau de chaque support (faïence, acrylique, etc.)
- Use a silicone sealant that is intended for the surrounding materials (ceramic, acrylic, etc.)
  - Usar una silicona adecuada para cada tipo de material (loza, acrílico, etc.)
  - Utilizzare un silicone adatto a qualsiasi materiale (ceramica, acrilico, ecc.)
  - Gebruik siliconenkit die geschikt is voor iedere ondergrond (tegelwerk, acryl, etc.)
  - Für das jeweilige Trägermaterial (Stein, Acryl usw.) geeignetes Silikon verwenden.



1A

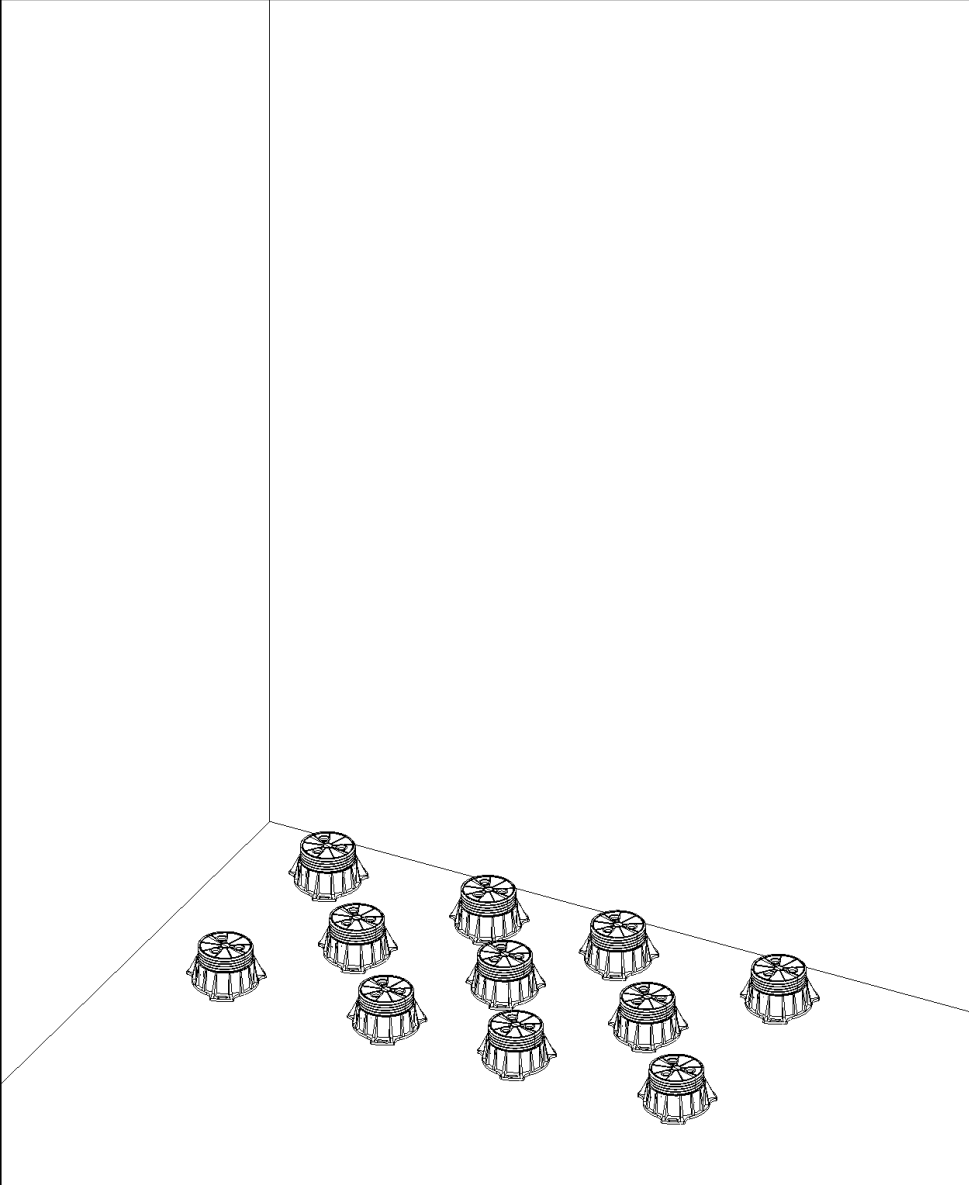

1B

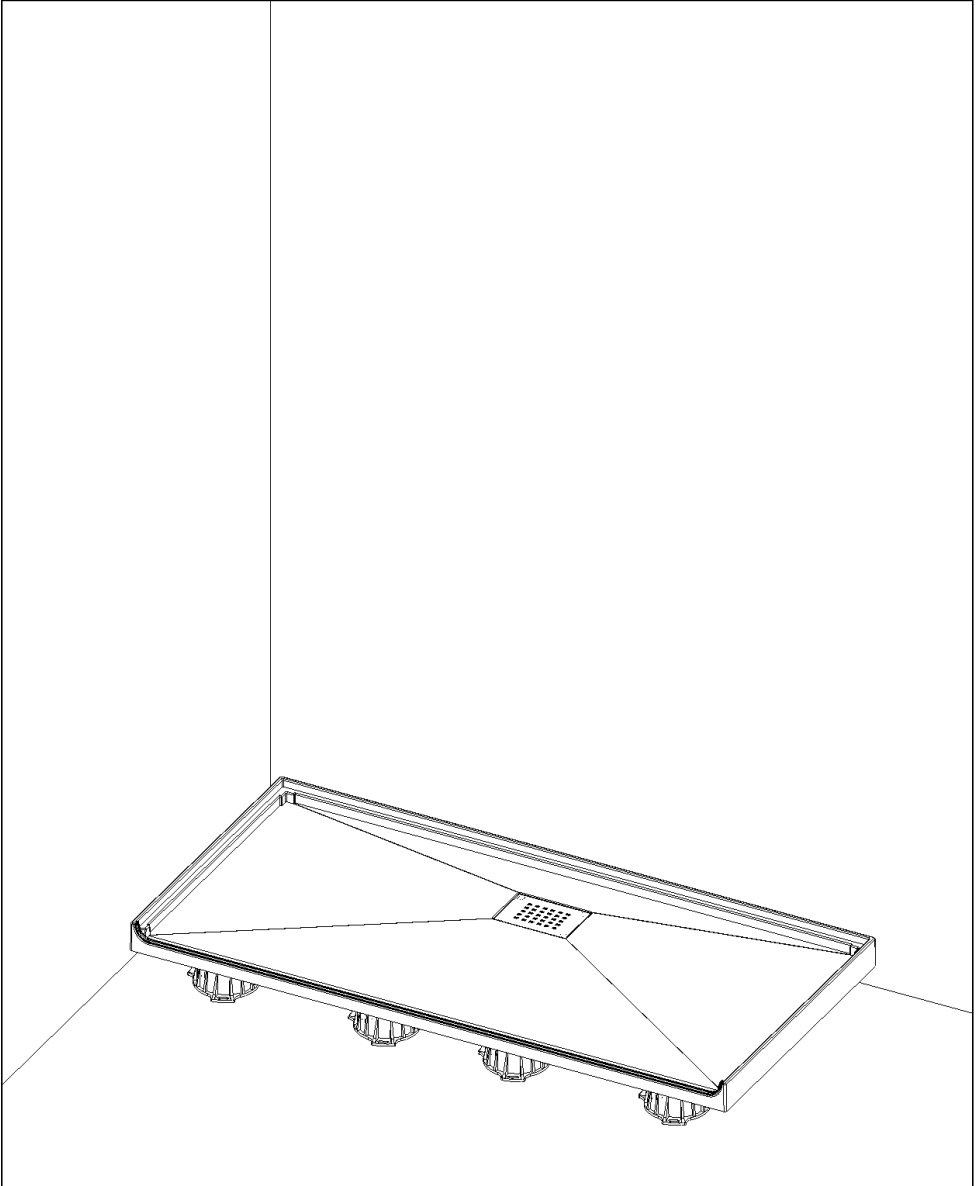

1C

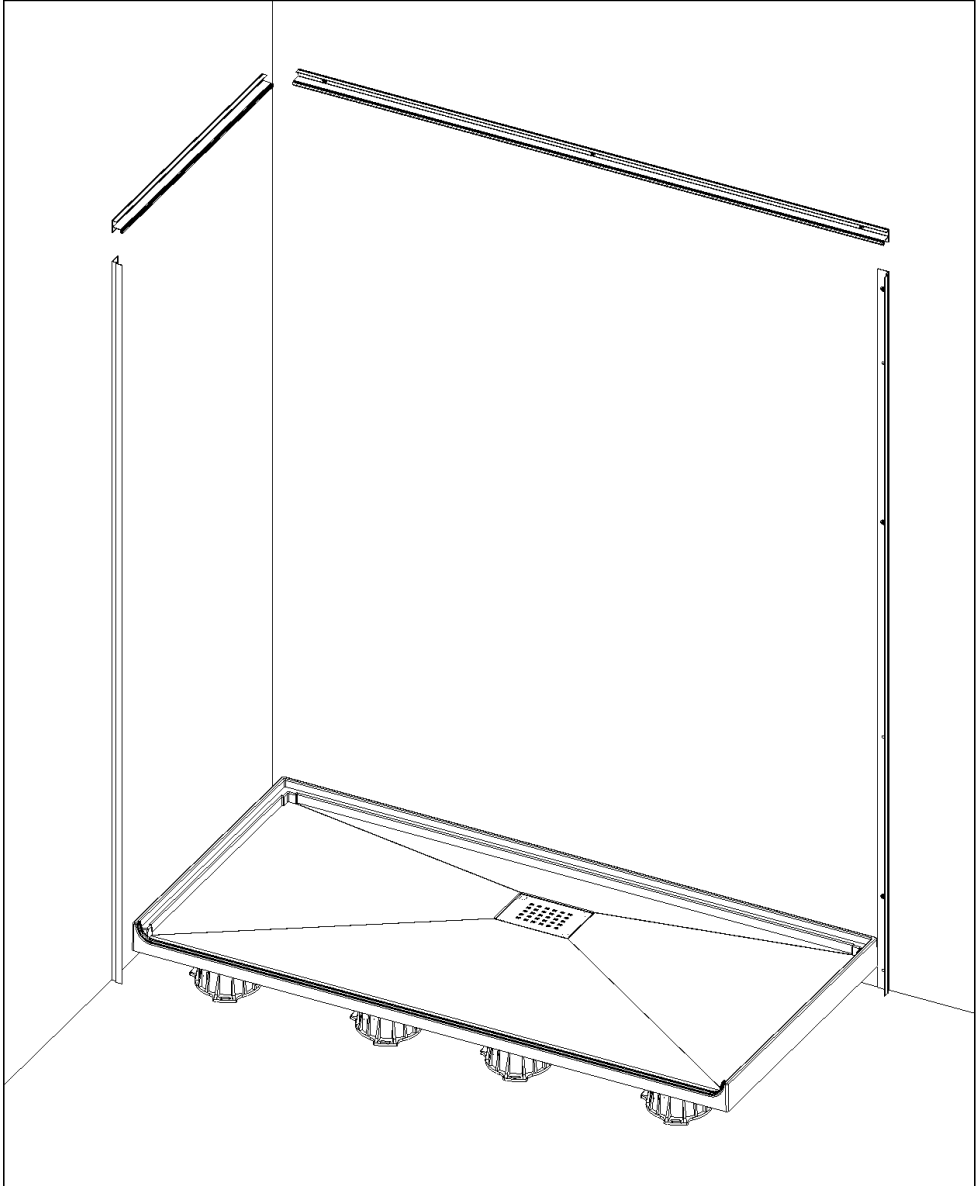

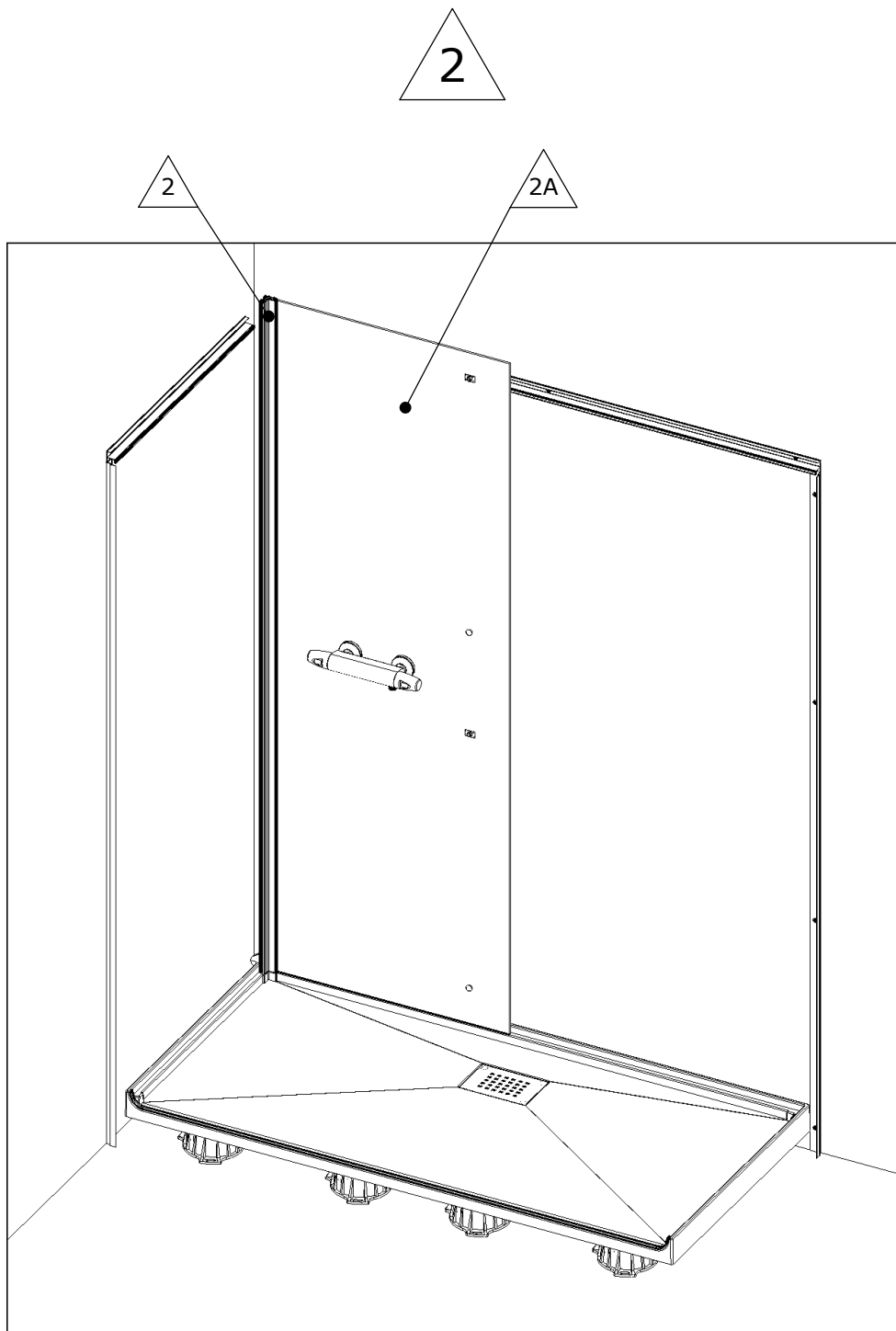

2

2

2B

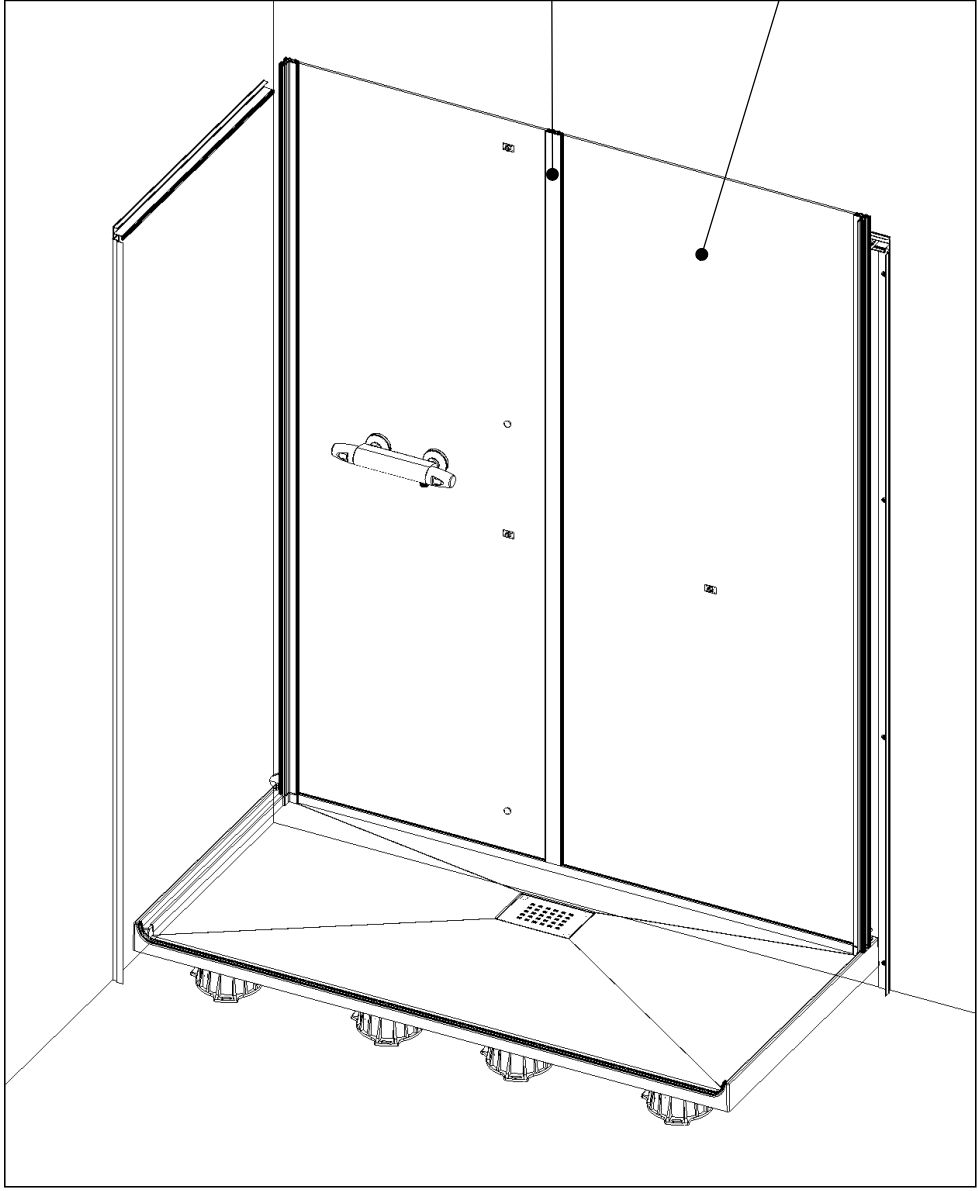

2

2C

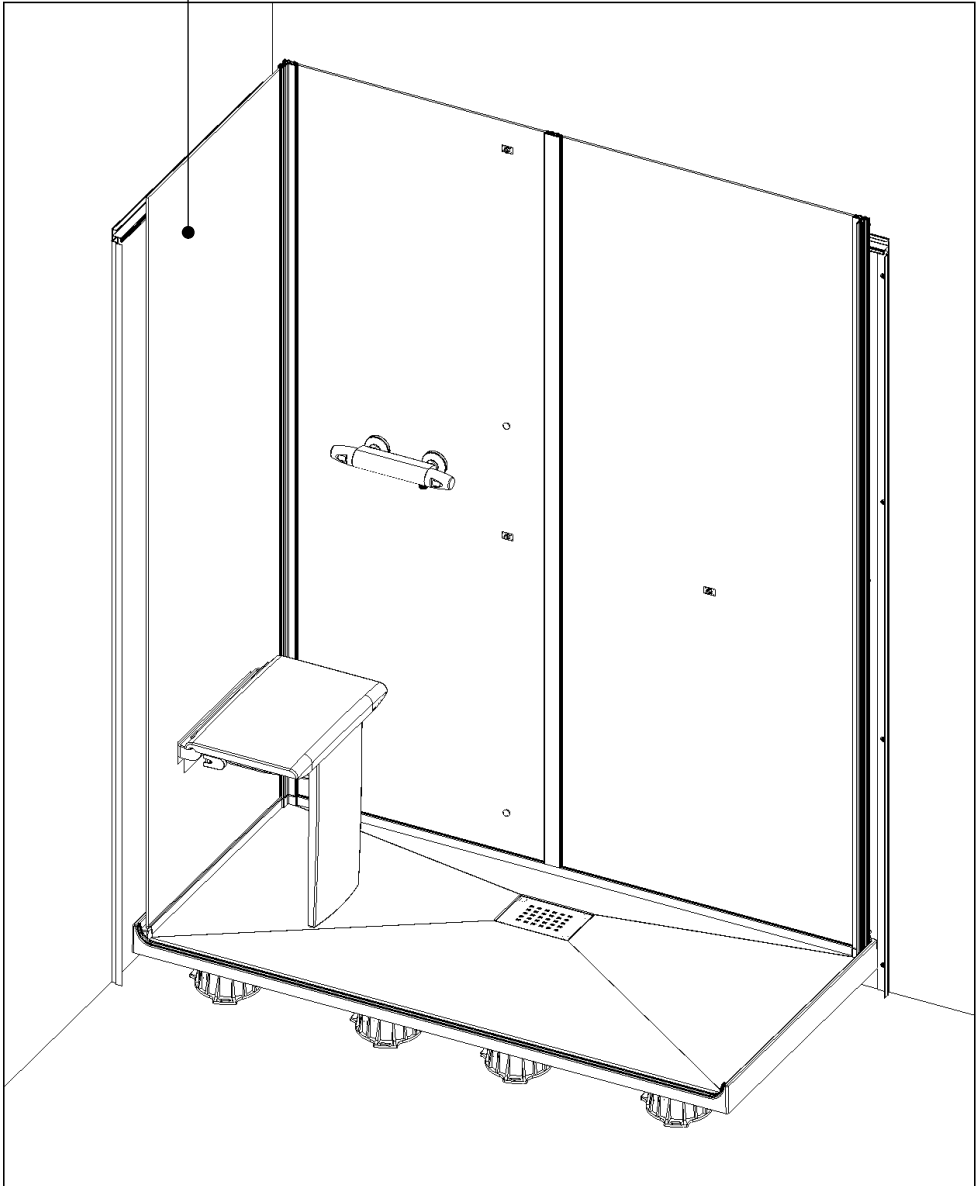

3

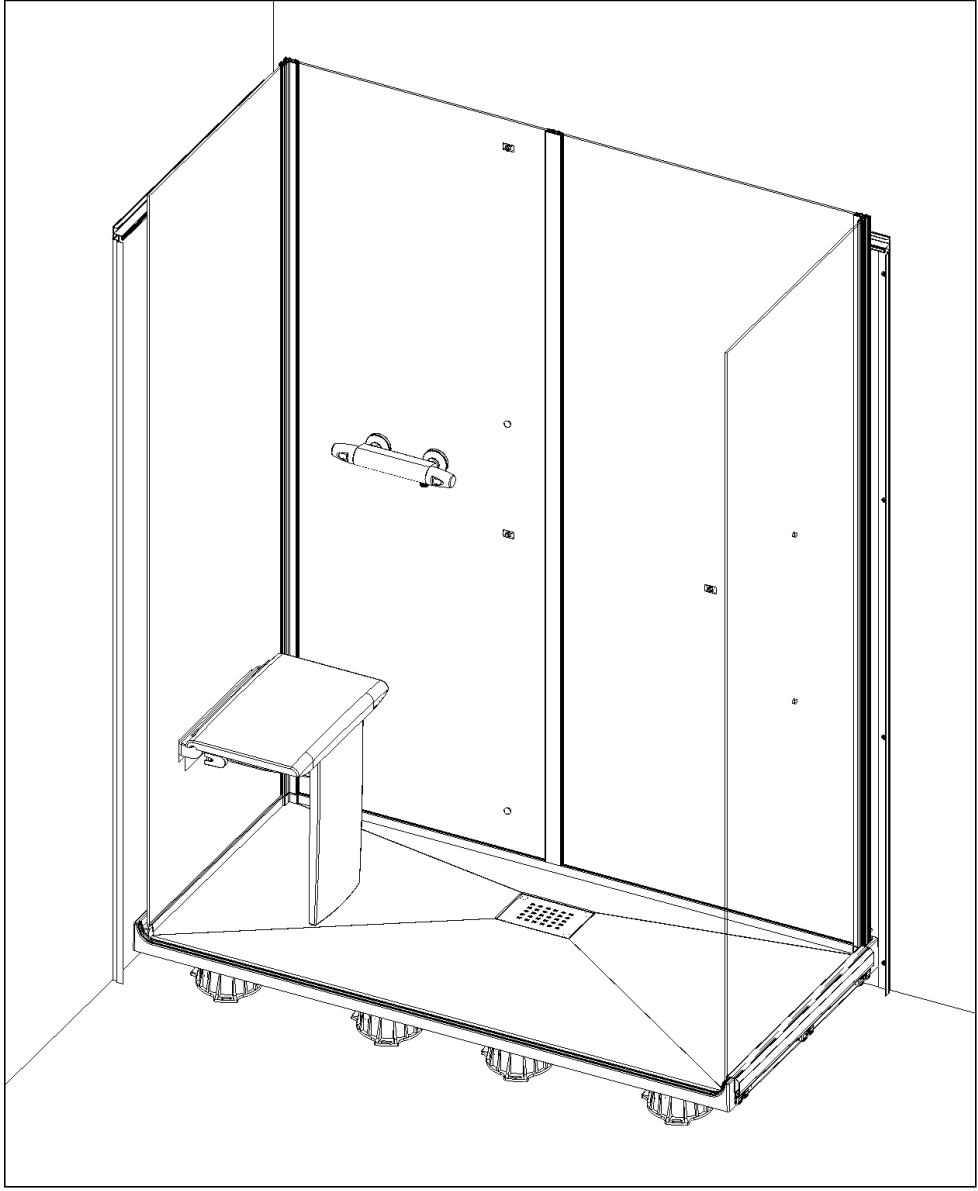

4

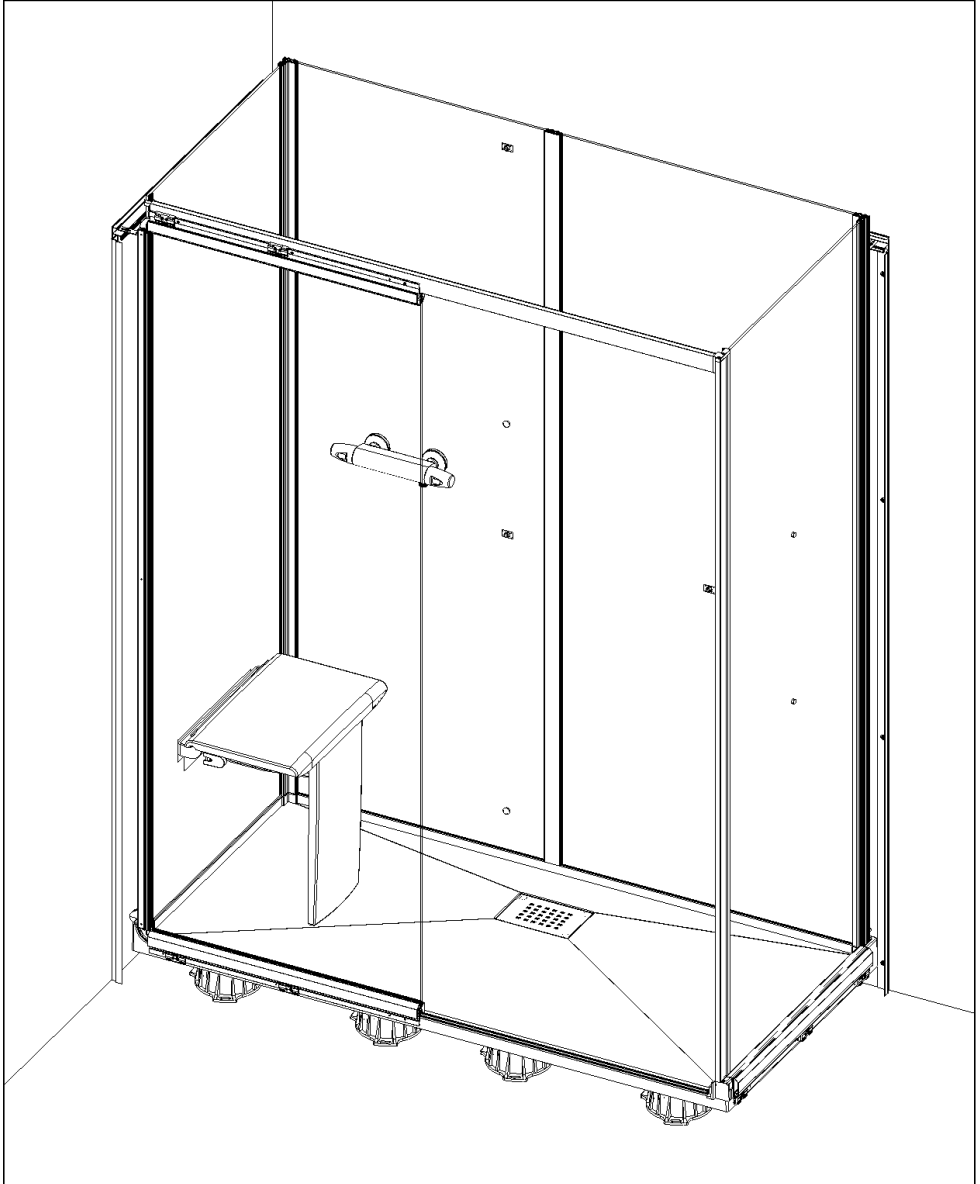

5

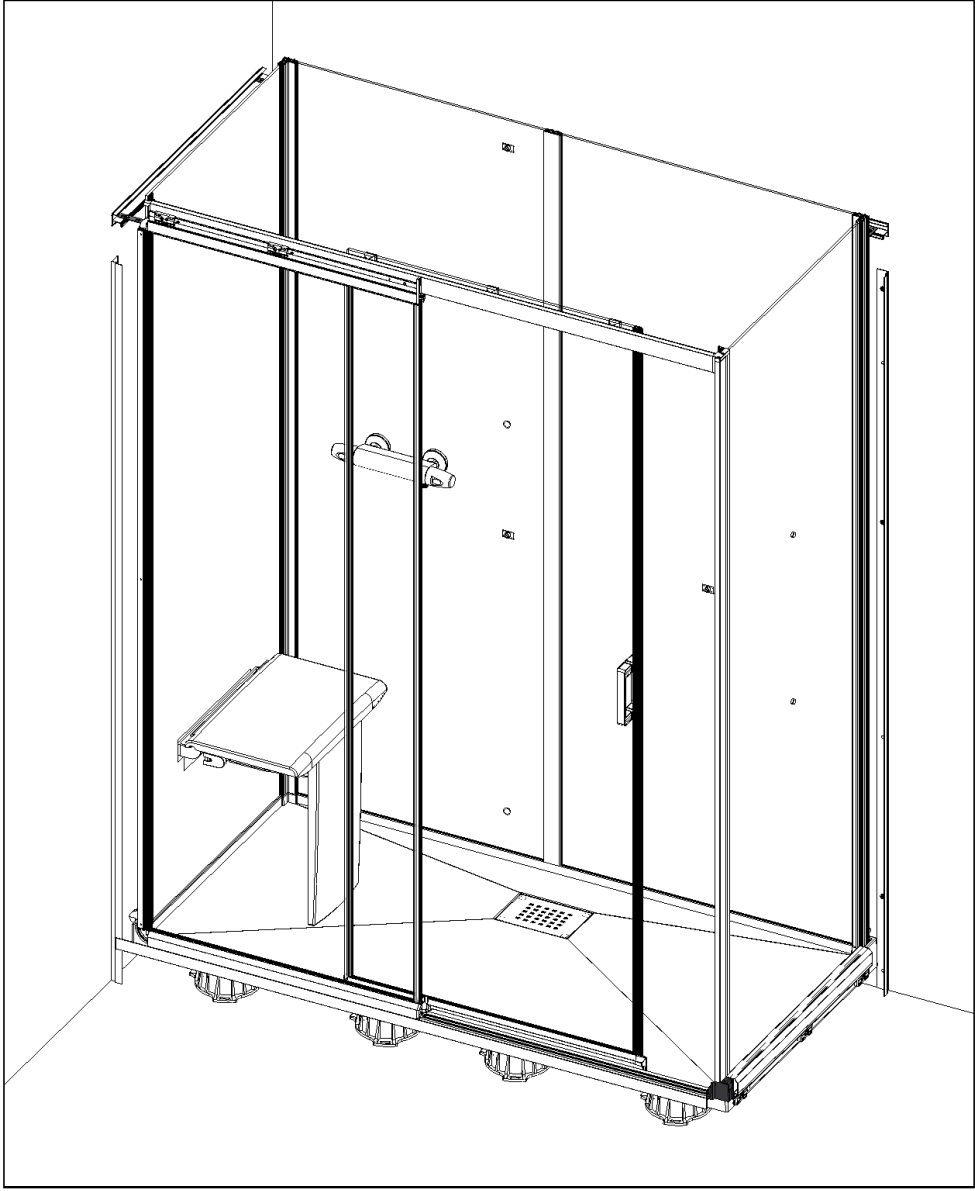

6

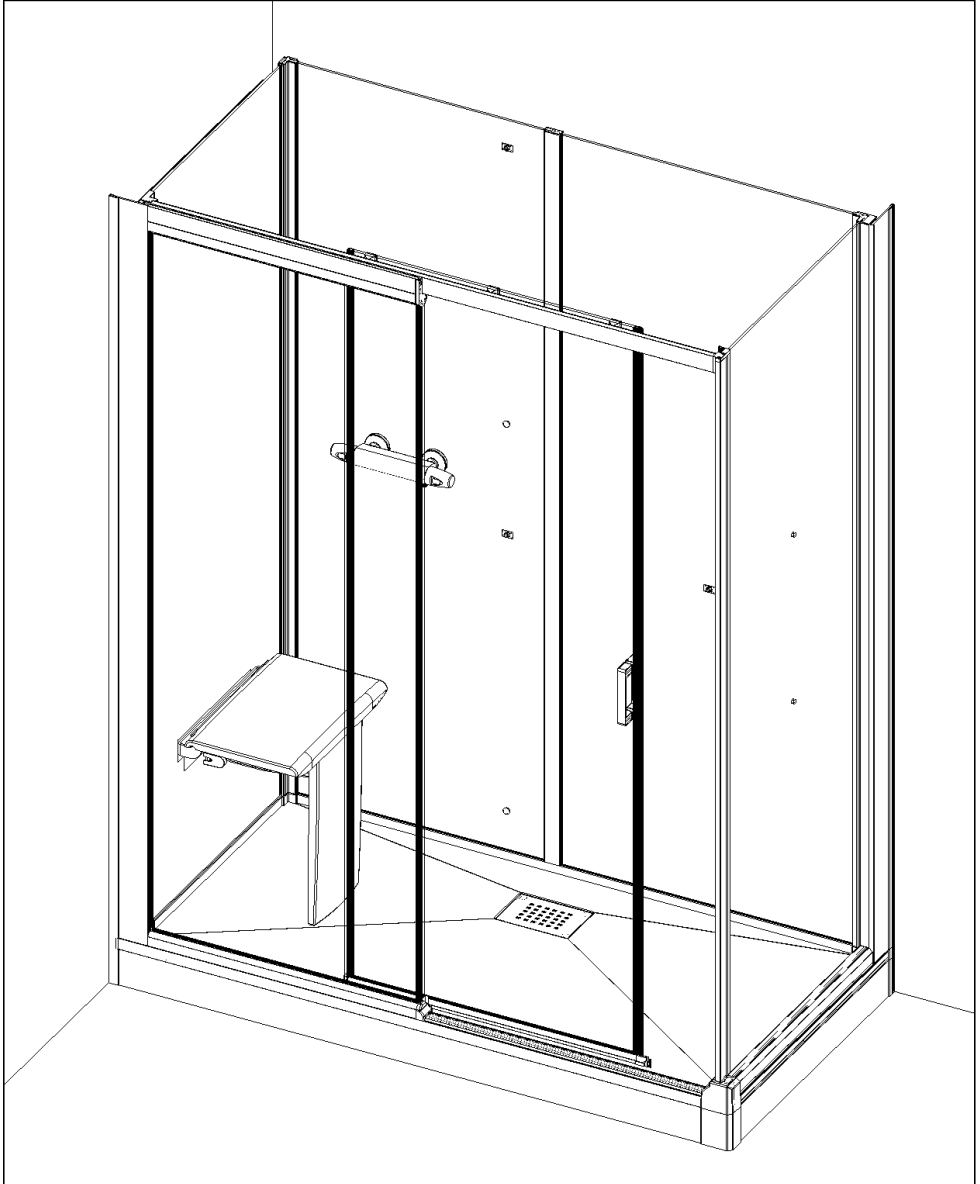

7

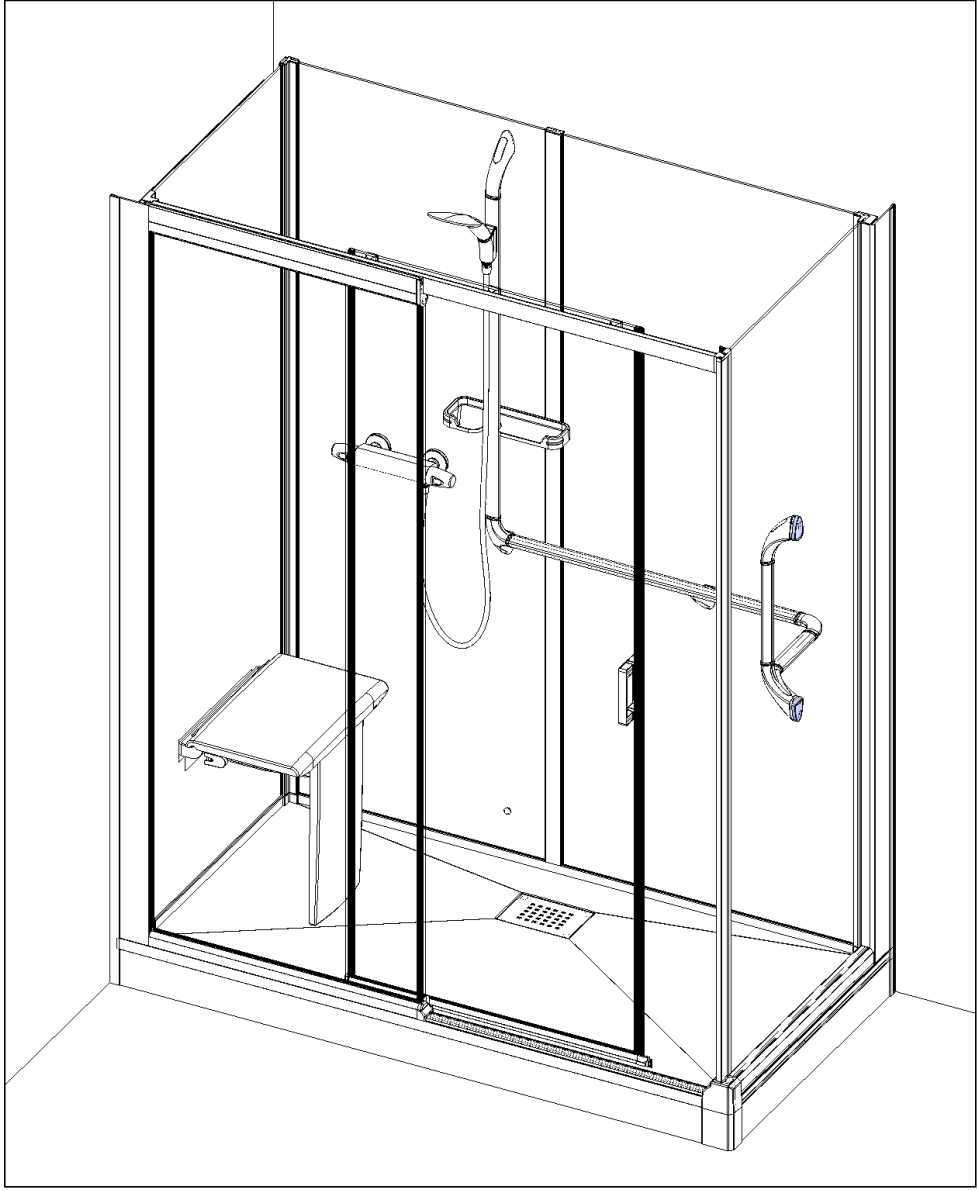

- Zone de décaissement pour un montage de receveur sans pieds
- Area required for the installation of the tray without feet
- Zona rebajada para la instalación del plato sin pies
- Zone necessarie per un montaggio del piatto senza piedi
- Aflooplegebied voor de montage van een douchebak zonder poten
- Freier Raum für Montage der Duschanne ohne FüÙe

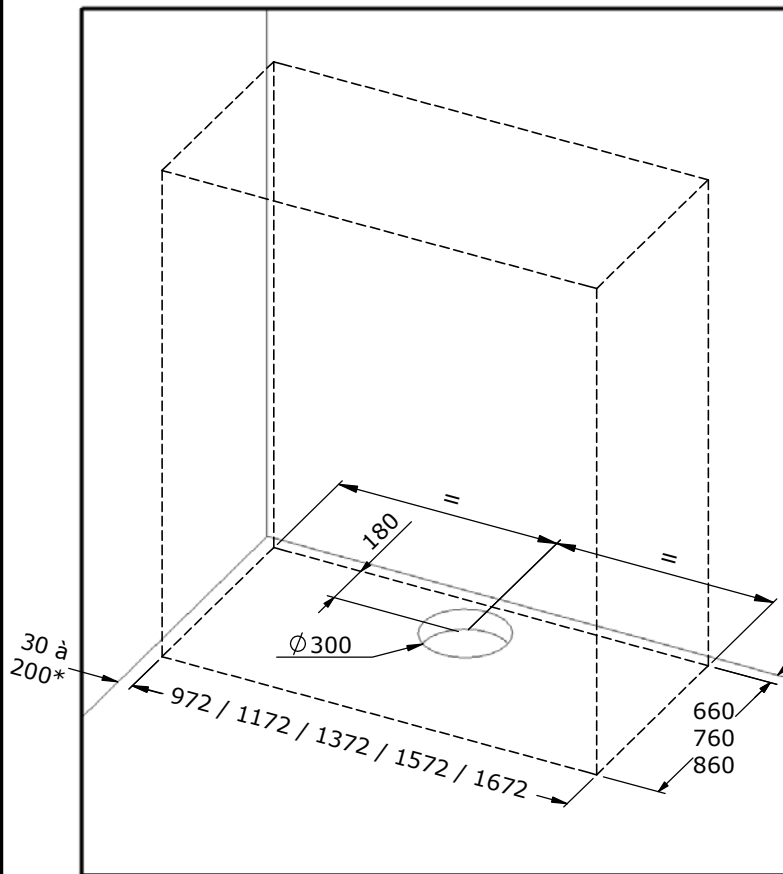

- \* ● Côté gauche et droit cumulés ne peuvent excéder 385 mm.
- Left and right sides summed must not exceed 385 mm.
- Las cuotas agregadas izquierda y derecha no pueden superar 385 mm.
- Sinistra e destra combinati non possono superare 385 mm.
- De linker- en rechterzijde mogen samen niet groter zijn dan 385 mm.
- Links und rechts dürfen es zusammen nicht mehr als 385 mm sein.

● Cotes en mm ● Dimensions in mm ● Cotas en mm

● Quote in mm ● Afmetingen in mm ● Maße sind in mm angegeben

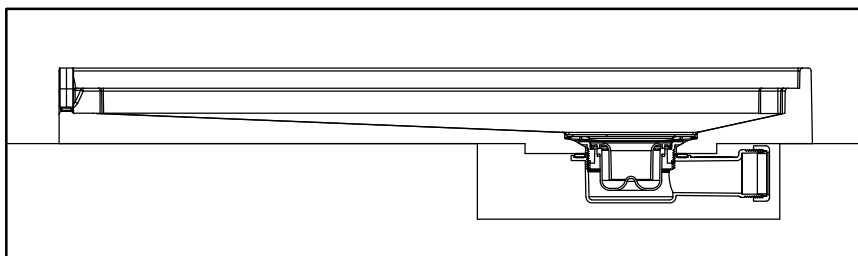









**SAV**  
**SERVICE HELPLINES**  
**ASSISTENZA POST-VENDITA**  
**SERVICIO POSTVENTA**

**FRANCE**

02 40 21 29 45

**SCHWEIZ**

(01) 748 17 44

**UK**

020 8842 0033

**ESPAÑA**

93 544 60 76

**IRELAND**

04697 33102

**NEDERLAND**

+31 475 487 100

**DEUTSCHLAND**

+49 (0) 6074 / 30928 0

**BELGIE**

+31 475 487 100

**ITALIA**

(0382) 6181

**BELGIQUE**

+31 475 487 100

**ÖSTEREICH**

+43 1 710 60 70

**РОССИЯ**

963 19 40, 773 67 22