 <p>Lg=1994mm Lg=2245mm</p>	<p>Ø3.5</p> 	<p>x1</p> <p>x3</p> <p>VIS231</p>
<p>x3</p>  <p>CHE02</p>	<p>x1</p>  <p>Lg=1992mm Lg=2243mm</p> <p>JOI299</p>	<p>x1</p>  <p>PPL1266</p>
<p>Ø3.5</p> <p>x1</p>  <p>VIS261</p>	<p>x3</p>  <p>PPL1196</p>	

Les quantités données sont les quantités utiles au montage. les sachets fournis contiennent des pièces supplémentaires.
The quantities given are what are required for the installation. There may be some surplus in the package provide.

Matériel nécessaire / Tools required / Herramientas necesarias
Ferramentas necessárias / Materiale necessario
Benodigd gereedschap / Benötigte Werkzeuge

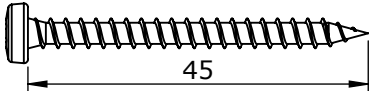

Ø 6 mm

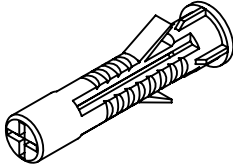
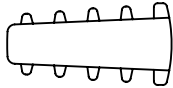
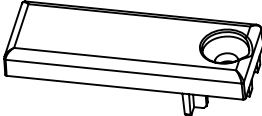
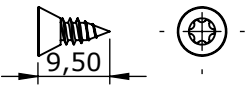
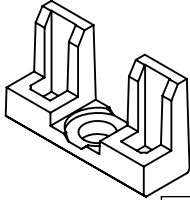
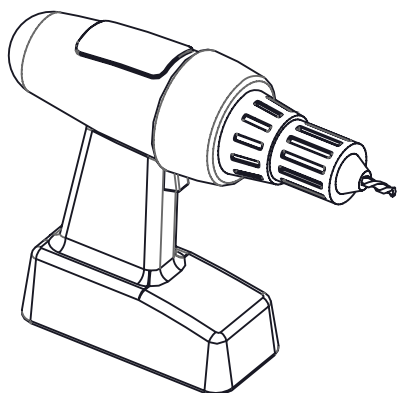
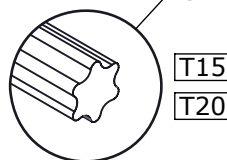
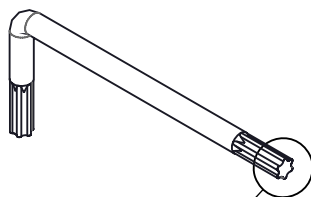
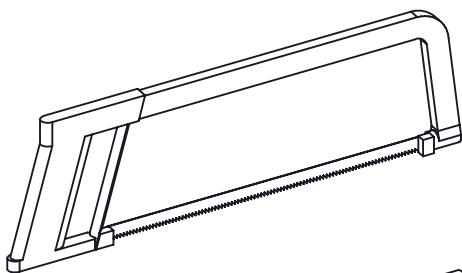
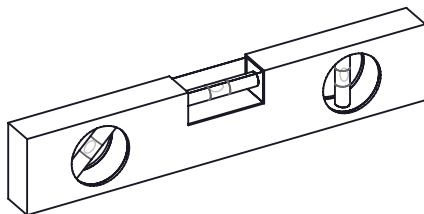

T15

T20



Utiliser un silicone adapté au matériau de chaque support (faïence, acrylique, etc.)

Use a silicone sealant that is intended for the surrounding materials (ceramic, acrylic, etc)

Usar una silicona adecuada para cada tipo de material (loza, acrílico, etc.)

Use um silicone adequado para cada tipo de material (cerâmica, acrílico, etc.)

Utilizzare un silicone adatto a qualsiasi materiale (ceramica, acrilico, ecc.)

Gebruik siliconenkit die geschikt is voor iedere ondergrond (tegelwerk, acryl, etc.)

Für das jeweilige Trägermaterial (Stein, Acryl usw.) geeignetes Silikon verwenden.



RÉVERSIBILITÉ / REVERSIBILITY / REVERSIBILITAD / REVERSIBILIDADE
REVERSIBILITÀ / OMKEERBAARHEID / WAHLWEISE MONTAGE

Montage à gauche
 Left hand
Montaje a la izquierda
 Montagem à esquerda
Montaggio a sinistra
 Montage links
Montage links

Montage à droite
 Right hand
Montaje a la derecha
 Montagem à direita
Montaggio a destra
 Montage rechts
Montage rechts

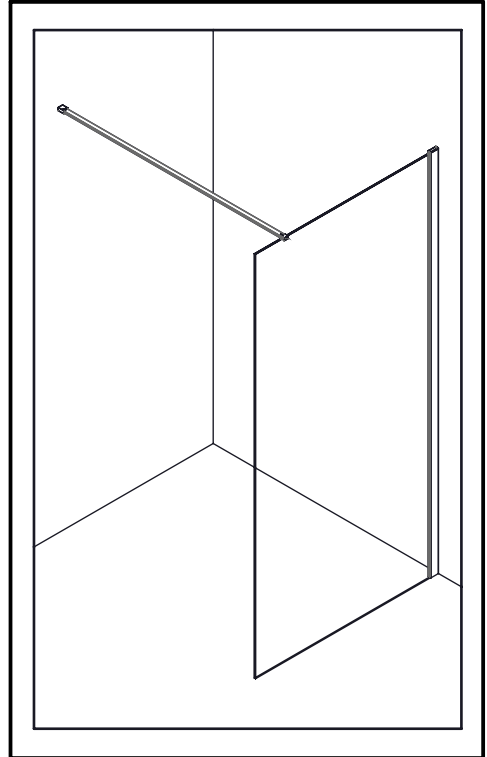
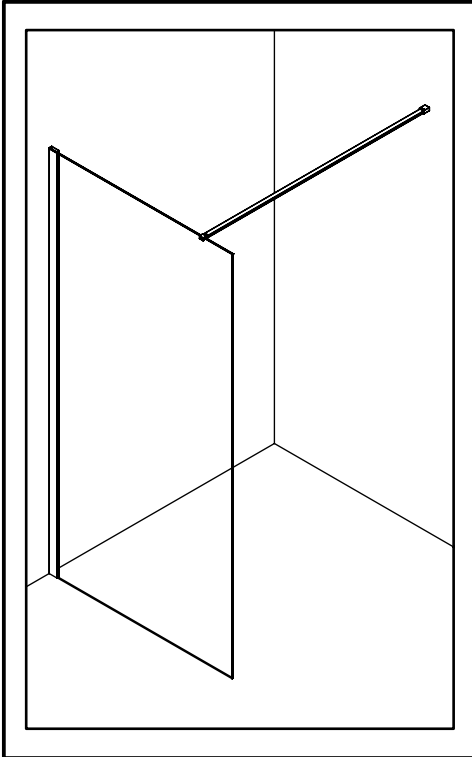

Vous avez la possibilité de réaliser un montage à droite ou un montage à gauche. Notre notice d'installation décrit un montage à gauche. Si vous voulez réaliser un montage à droite, il vous suffit d'inverser le montage.

This cubicle can be installed either left or right hand. These installation instructions show a left hand installation.

Puede realizar un montaje a la derecha o un montaje a la izquierda. Nuestro folleto de instalación describe un montaje a la izquierda. Si desea montar su cabina a la derecha sólo tendrá que realizar el montaje al contrario.

Você pode montar à direita ou montar à esquerda.

Nosso folheto de instalação descreve uma montagem à esquerda. Se quiser montar sua cabine à direita, basta montá-la à direita.

Avete la possibilità di effettuare il montaggio a destra o a sinistra. Il nostro manuale descrive il montaggio a sinistra. Se volete realizzare il montaggio a destra è sufficiente invertire varie fasi di montaggio.

U kunt de douchecabine rechts of links monteren. Onze handleiding beschrijft de links montage van de cabine. Keer de montage om als u de cabine rechts wilt monteren.

Sie haben die Möglichkeit, eine Montage auf der linken Seite oder eine Montage auf der rechten Seite durchzuführen. Unsere Montageanleitung beschreibt eine Montage auf der linken Seite. Wenn Sie die Montage lieber auf der rechten Seite durchführen wollen, müssen Sie nur den Montageprozess umkehren.

a

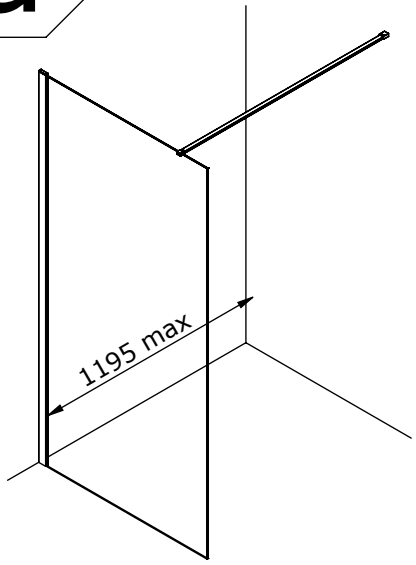

b

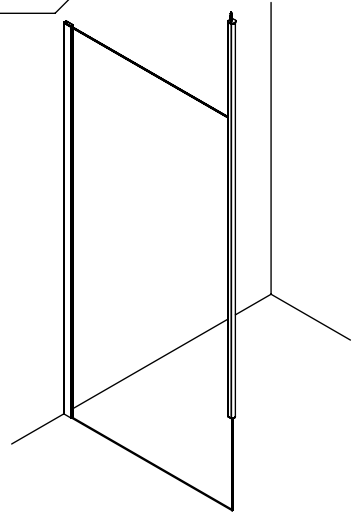

C

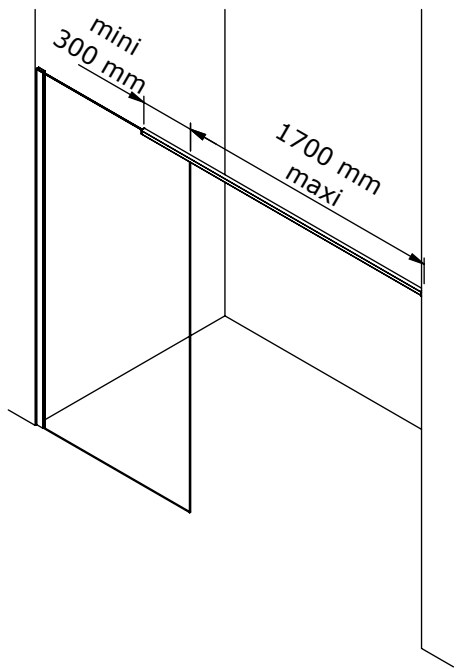

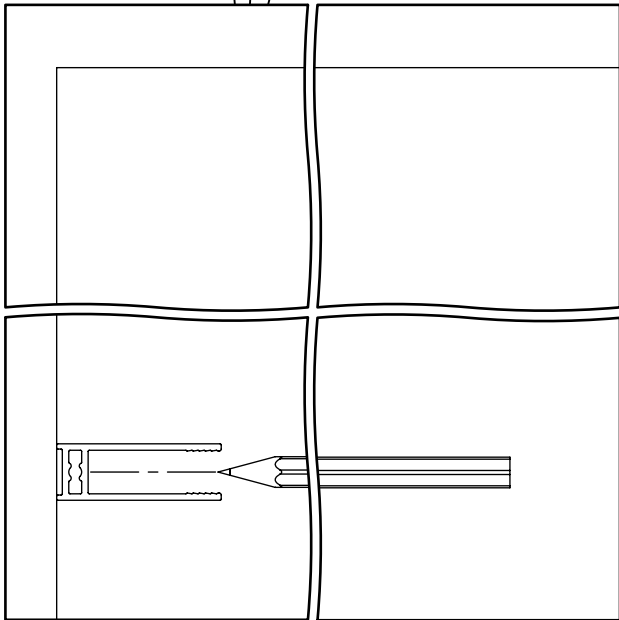
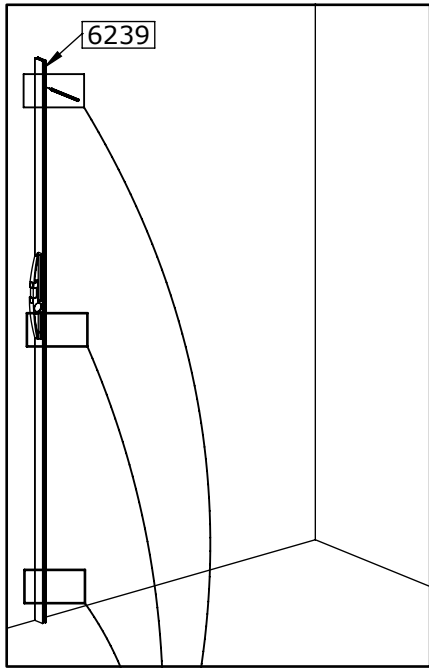

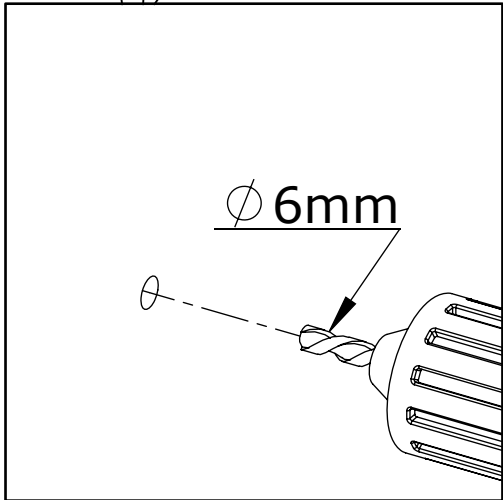
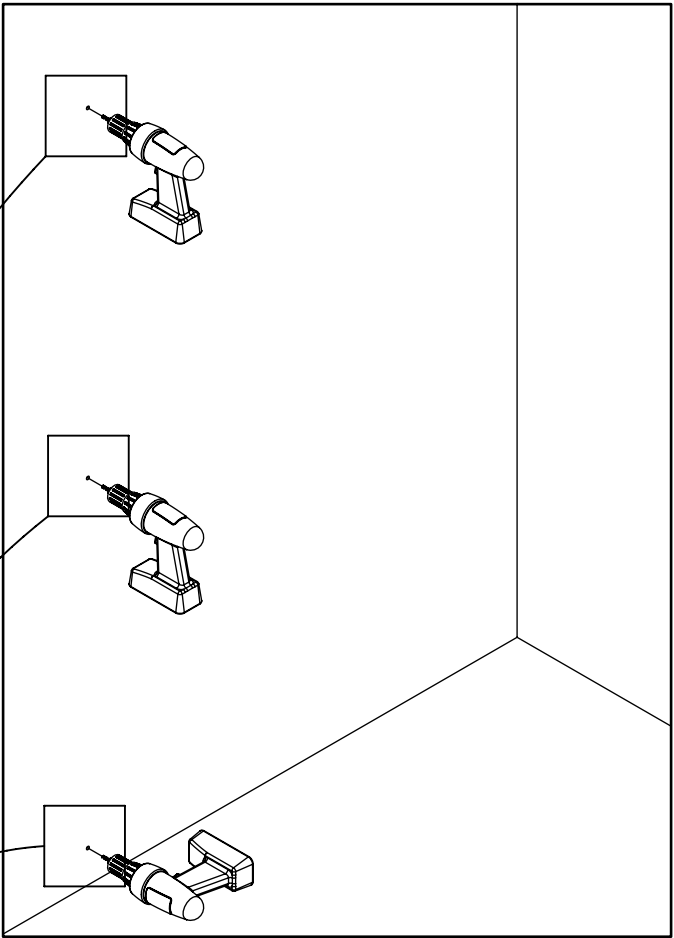

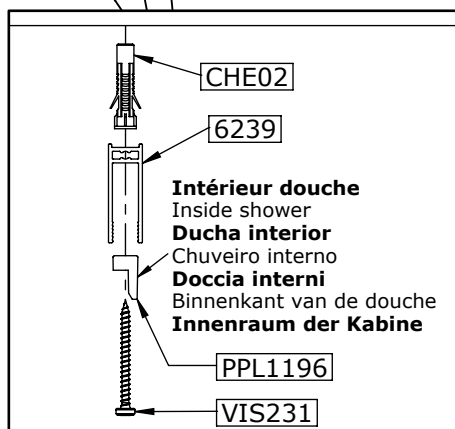
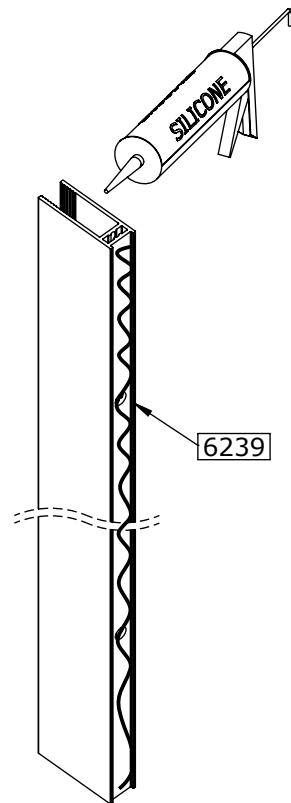
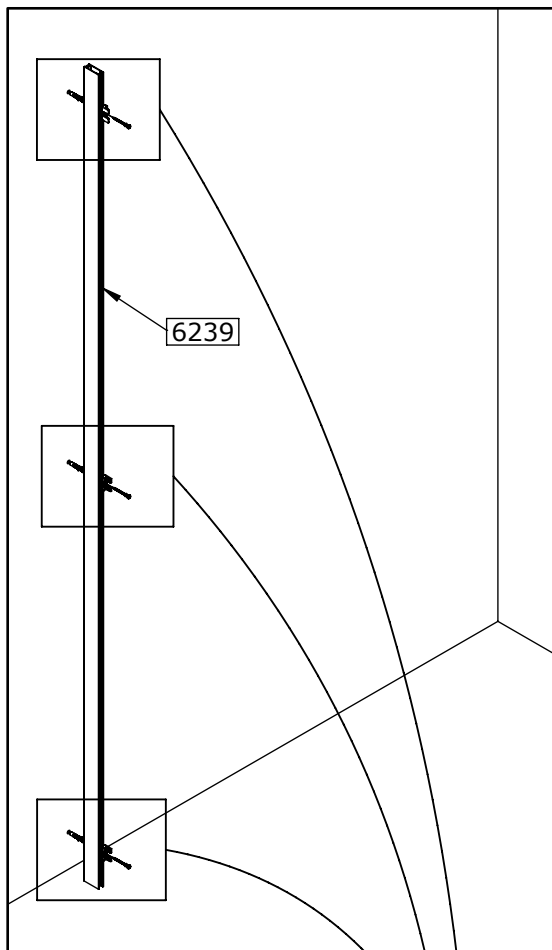

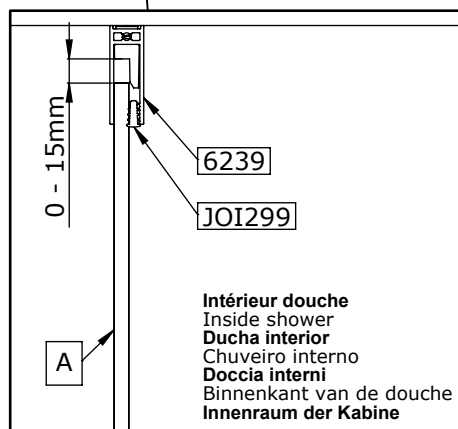
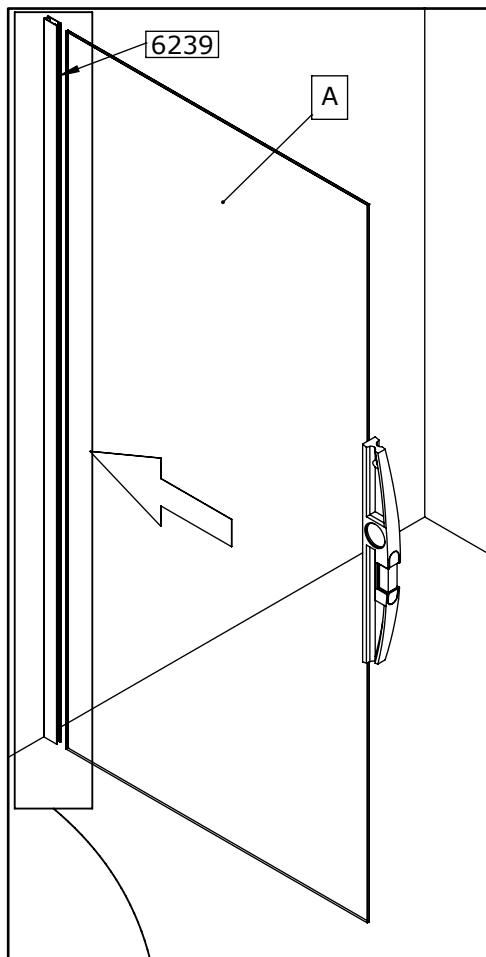

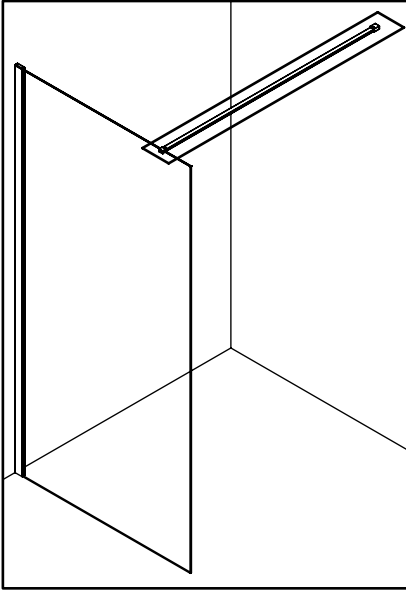

Voir notice concernée
See installation instructions required
Ver manual adecuado
Ver manual adecuado
Vedere manuale appropriato
Zie de bijbehorende montagehandleiding
Siehe betreffende Anleitung

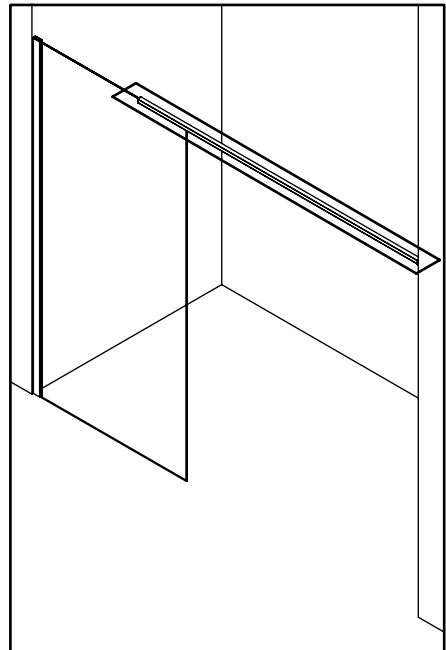
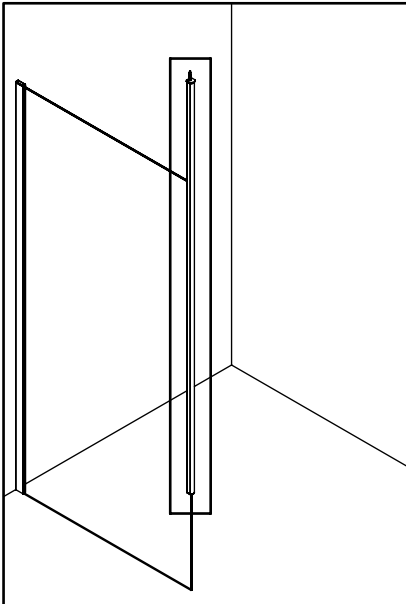

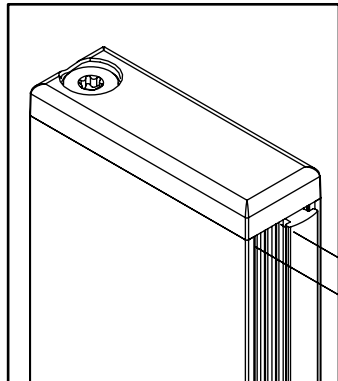
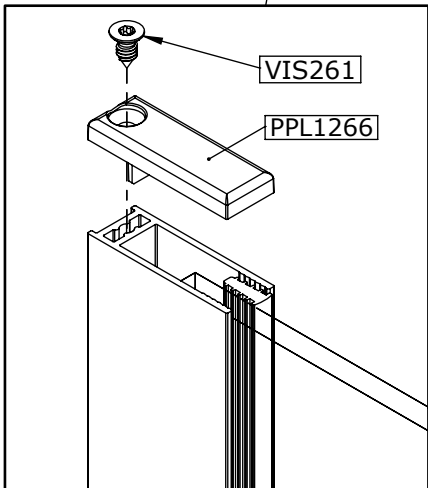
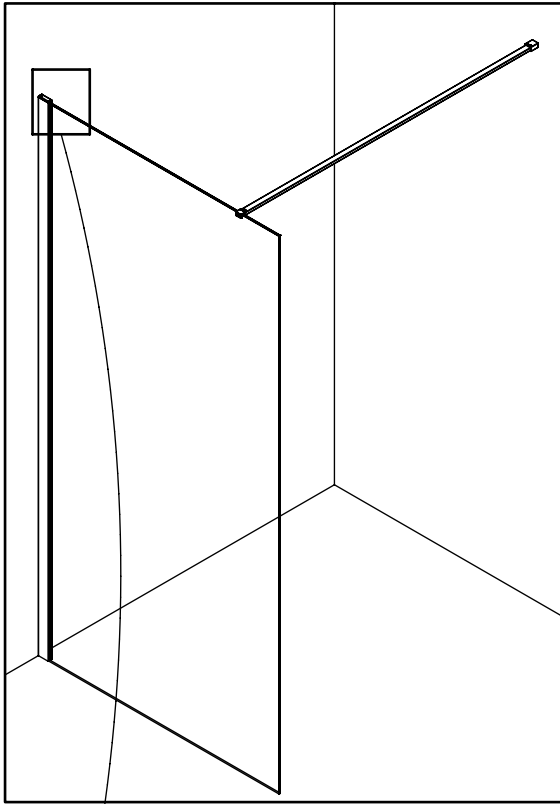

24H

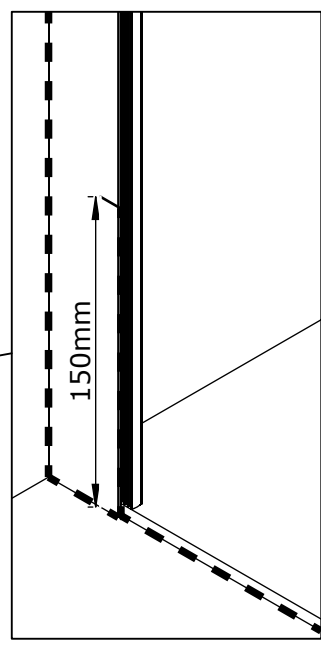
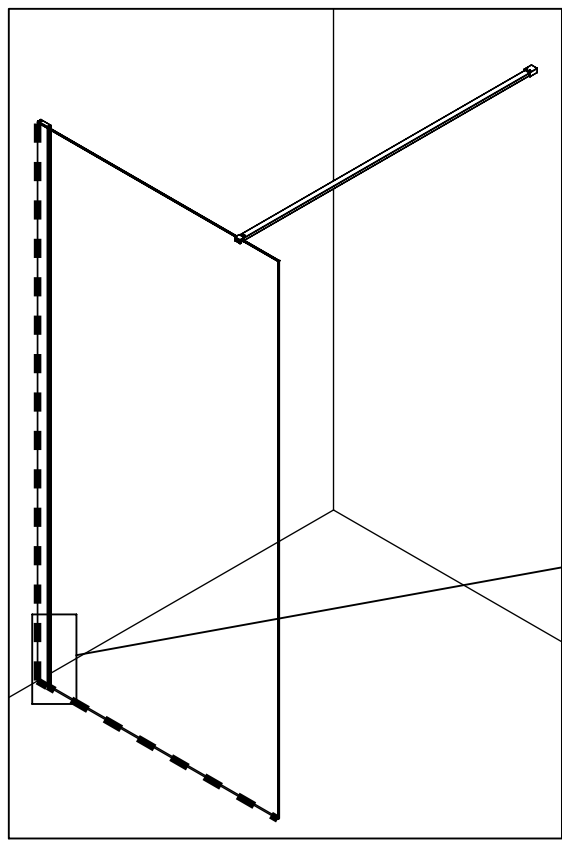
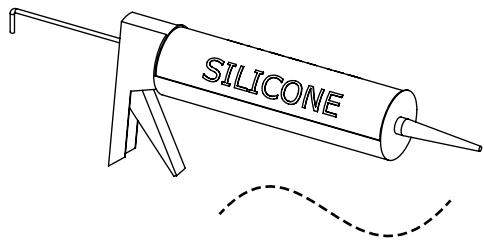



<p>FR</p> <p>Bon de garantie</p> <p>SCANEZ MOI</p>  <p>http://tiny.cc/bon-de-garantie-fr</p>	<p>GB</p> <p>Guarantee</p> <p>SCAN ME</p>  <p>http://tiny.cc/bon-de-garantie-gb</p>
<p>DE</p> <p>Garantiekarte</p> <p>SCAN MICH</p>  <p>http://tiny.cc/bon-de-garantie-de</p>	<p>NL</p> <p>Garantievoorwaarden</p> <p>SCAN MIJ</p>  <p>http://tiny.cc/bon-de-garantie-nl</p>
<p>ES</p> <p>Garantía</p> <p>ESCANÉAME</p>  <p>http://tiny.cc/bon-de-garantie-es</p>	<p>IT</p> <p>Garanzia</p> <p>SCANSIONAMI</p>  <p>http://tiny.cc/bon-de-garantie-it</p>
<p>PT</p> <p>Garantia</p> <p>ESCANEEI-ME</p>  <p>http://tiny.cc/bon-de-garantie-pt</p>	<p>CH</p> <p>Garantiekarte</p> <p>SCAN MICH</p>  <p>http://tiny.cc/bon-de-garantie-ch</p>
<p>BE</p> <p>Garantievoorwaarden</p> <p>SCAN MIJ</p>  <p>http://tiny.cc/bon-de-garantie-be</p>	<p>AT</p> <p>Garantiekarte</p> <p>SCAN MICH</p>  <p>http://tiny.cc/bon-de-garantie-at</p>



Kinedo

FR

Conseils
d'entretien

SCANEZ MOI



<http://tiny.cc/conseils-entretien-fr>

GB

Maintenance
instructions

SCAN ME



<http://tiny.cc/conseils-entretien-gb>

DE

Wartungstipps

SCAN MICH



<http://tiny.cc/conseils-entretien-de>

NL

Onderhoudstips

SCAN MIJ



<http://tiny.cc/conseils-entretien-nl>

ES

Consejos de
mantenimiento

ESCANÉAME



<http://tiny.cc/conseils-entretien-es>

IT

Consigli per la
manutenzione

SCANSIONAMI



<http://tiny.cc/conseils-entretien-it>

PT

Dicas de
manutenção

ESCANEEI-ME



<http://tiny.cc/conseils-entretien-pt>

CH

Wartungstipps

SCAN MICH



<http://tiny.cc/conseils-entretien-ch>

BE

Onderhoudstips

SCAN MIJ



<http://tiny.cc/conseils-entretien-be>

AT

Wartungstipps

SCAN MICH



<http://tiny.cc/conseils-entretien-at>



SERVICE APRÈS-VENTE AFTER-SALES SERVICE

FRANCE

+33 (0)2 40 21 29 45

UK

+44 (0)20 8842 0033

IRELAND

+353 04697 33102

DEUTSCHLAND

+49 (0) 6074 / 30928 0

ITALIA

+39 02 30559420

ÖSTEREICH

+43 1 710 60 70

SUISSE/SCHWEIZ

+41 (0)32 631 04 74

ESPAÑA

+34 93 544 60 76

NEDERLAND

+31 475 487 100

BELGIQUE/BELGIË

+31 475 487 100

РОССИЯ

+7 495 258-29-51

PORTUGAL

+351 219 112 785



AQUAPRODUCTION, Site industriel,
F - 44680 Chaumes-en-Retz

24

EN 14428

Paroi de douche, fabriquée en verre de silicate
sodo-calcique de sécurité trempé thermiquement

Aptitude au nettoyage : réussite

Résistance à l'impact/propriétés de fragmentation : réussite

Durabilité : réussite