

Kinedo

DES1475-C

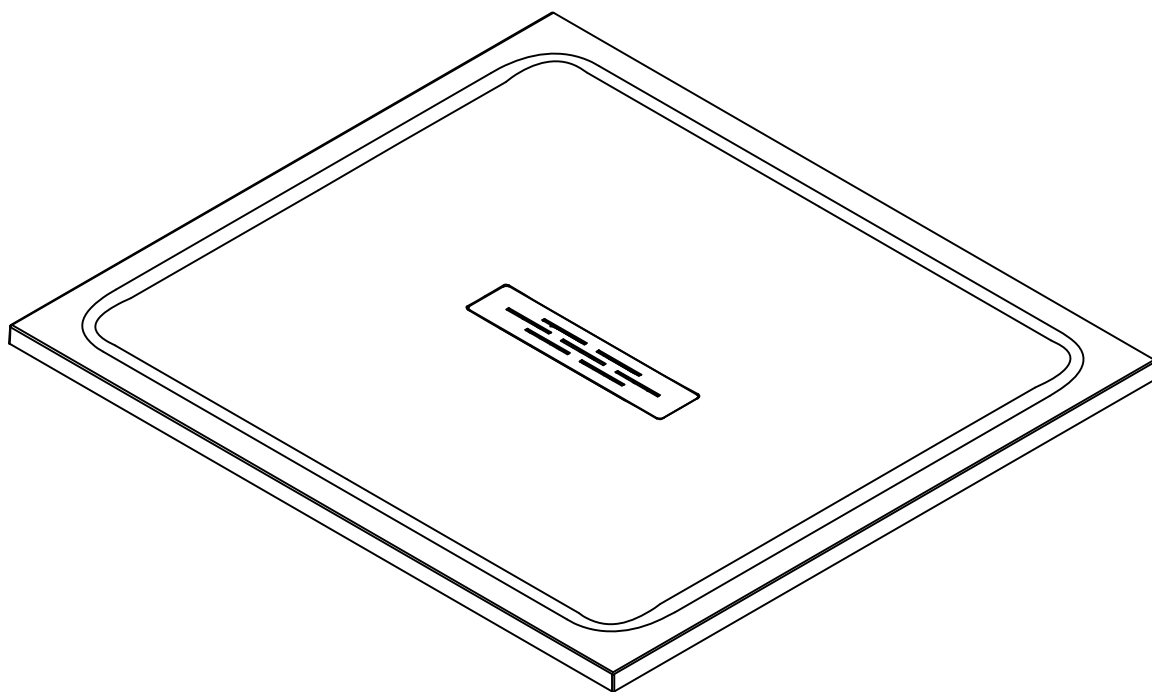

NOTICE DE MONTAGE / INSTALLATION INSTRUCTIONS / MANUAL DE INSTALACIÓN / MANUAL DE INSTALAÇÃO
ISTRUZIONI DI MONTAGGIO / INSTALLATIE VOORSCHRIFTEN / INSTALLATIONSANLEITUNG



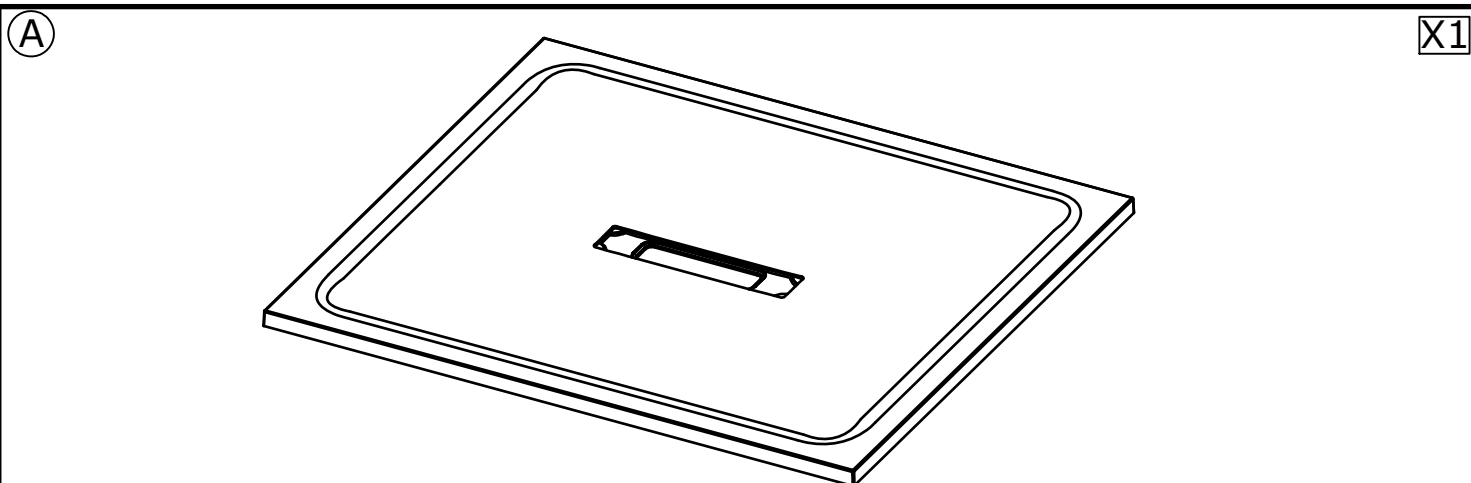

REC664	70X70	REC669	100X70	REC674	110X80	REC679	130X70	REC684	140X100	REC689	160X70	REC694	170X80	REC699	190X90
REC665	75X75	REC670	100X80	REC675	120X70	REC680	130X80	REC685	150X70	REC690	160X80	REC695	170X90	REC700	200X100
REC666	80X80	REC671	100X90	REC676	120X80	REC681	140X70	REC686	150X80	REC691	160X90	REC696	180X80		
REC667	90X70	REC672	100X100	REC677	120X90	REC682	140X80	REC687	150X90	REC692	160X100	REC697	180X90		
REC668	90X90	REC673	110X70	REC678	120X100	REC683	140X90	REC688	150X100	REC693	170X70	REC698	180X100		

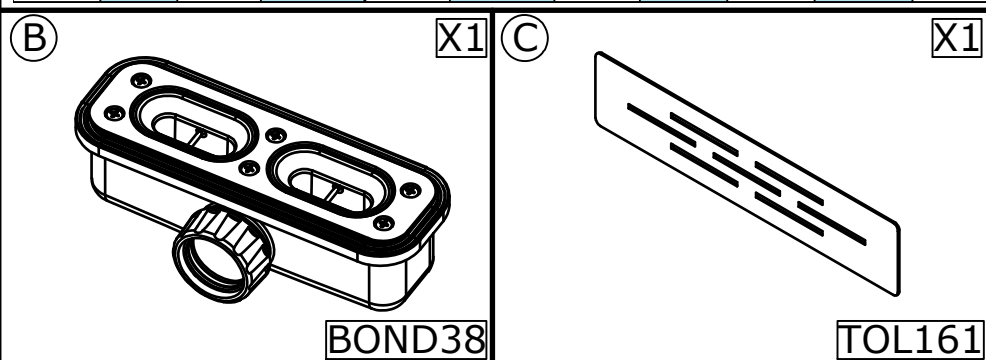

FR-Les quantités données sont les quantités utiles au montage. les sachets fournis contiennent des pièces supplémentaires.

GB-The quantities given are what are required for the installation. There may be some surplus in the package provide.

ES-Las cantidades indicadas son las cantidades necesarias para el montaje. Las bolsitas incluidas contienen piezas suplementarias.

PT-A quantidade indicada é a quantidade necessária para a montagem. As bolsas incluem peças adicionais.

IT-Le quantità fornite sono le quantità necessarie al montaggio. I sacchetti forniti contengono pezzi supplementari.

NL-De aangegeven aantallen zijn bestemd voor de montage. De bijgeleverde zakjes bevatten extra onderdelen

DE-Die Mengenangaben beziehen sich auf die für die Montage benötigten Teile. Es kann eine gewisse Überzahl an Teilen in der Packung vorhanden sein.

FR-Matériel nécessaire GB-Tools required
ES-Material necesario PT-Equipamento necessário
IT-Materiale necessario NL-Benodigdheden DE-Erforderliche Werkzeuge

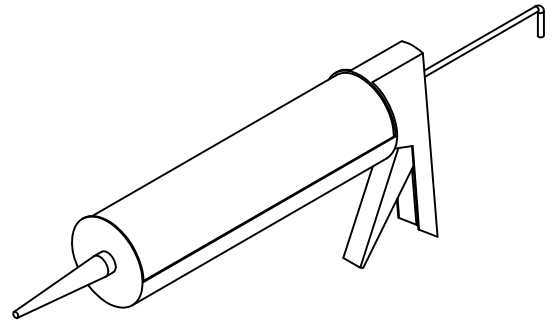
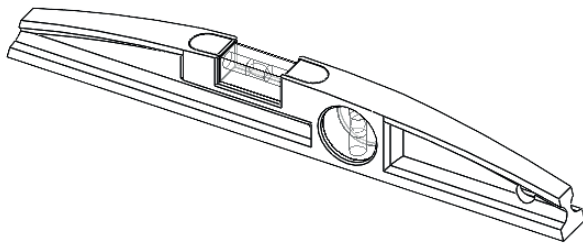

FR-Colle polyuréthane ou MS polymère
GB-Polyurethane adhesive or MS polymer
ES-Pegamento poliuretano o polímero MS
PT-Cola poliuretano ou polímero MS
IT-Colla poliuretanoica o MS polimero
NL-Polyurethaan of MS-polymeer lijm
DE-Polyurethan oder MS-Polymere
 Montagekleber verwenden

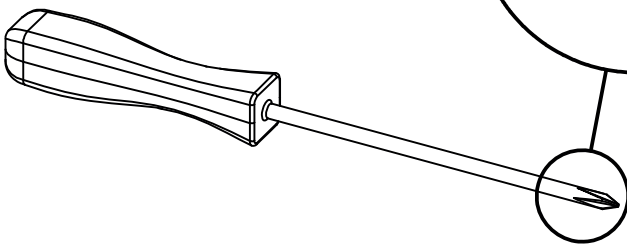
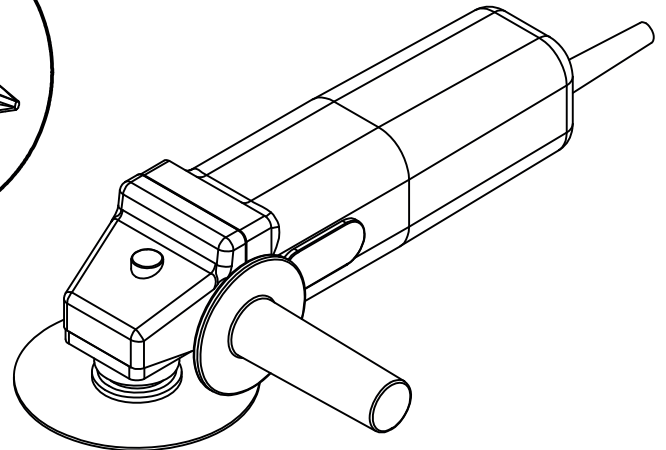
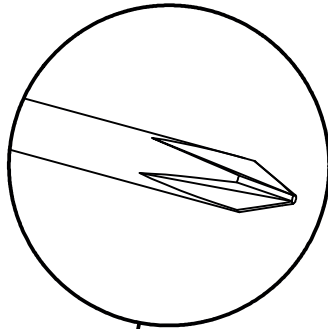
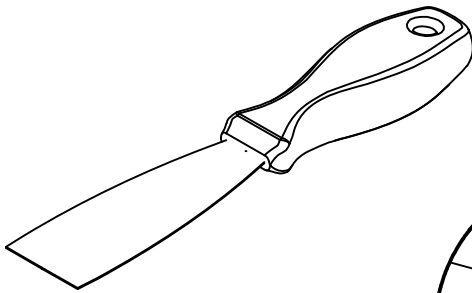

FR-Meuleuse avec lame diamant Ø230mm min.
GB-Grinder with diamond blade Ø230mm min.
ES-Pulidora con disco diamantado Ø230mm min.
PT-Rebarbadora con disco de diamante Ø230mm min.
IT-Mola con lama diamantata Ø230mm min.
NL-Diamantslijpschijf Ø230mm min.
DE-Winkelschleifer mit Diamanttrennscheibe Ø230mm min.

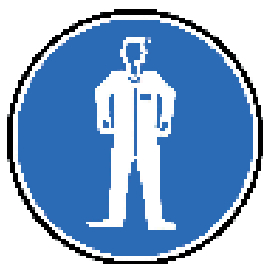

FR-DECOUPE OPTIONNELLE DU RECEVEUR **GB-ZONE AVAILABLE FOR OPTIONAL RECUTTING**
ES-RECORTE OPCIONAL **PT-CORTE OPCIONAL DA PLACA**
IT-TAGLIO OPZIONALE DEL PIATTO
NL-BIJSNIJDEN VAN DE DOUCHEBAK, OPTINEEL **DE-OPTIONALE SCHNEIDBEREICHE DER DUSCHWANNE**

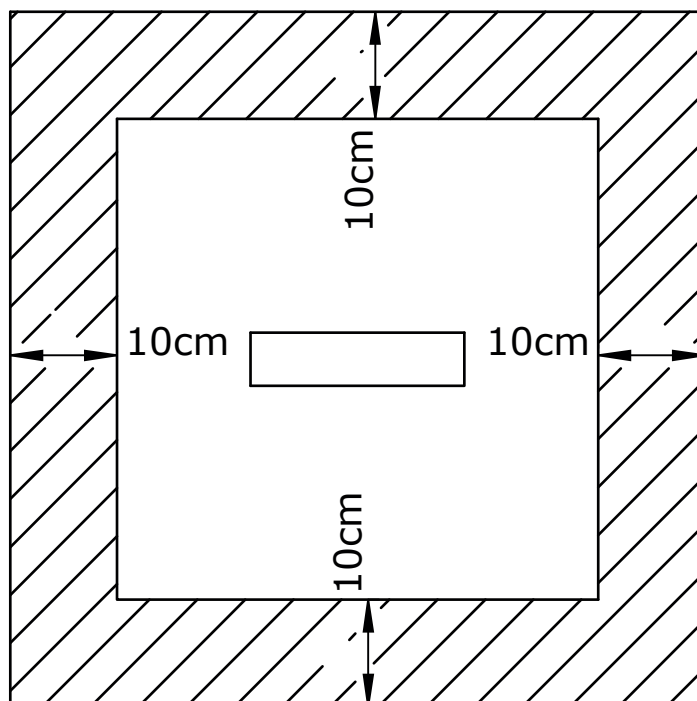
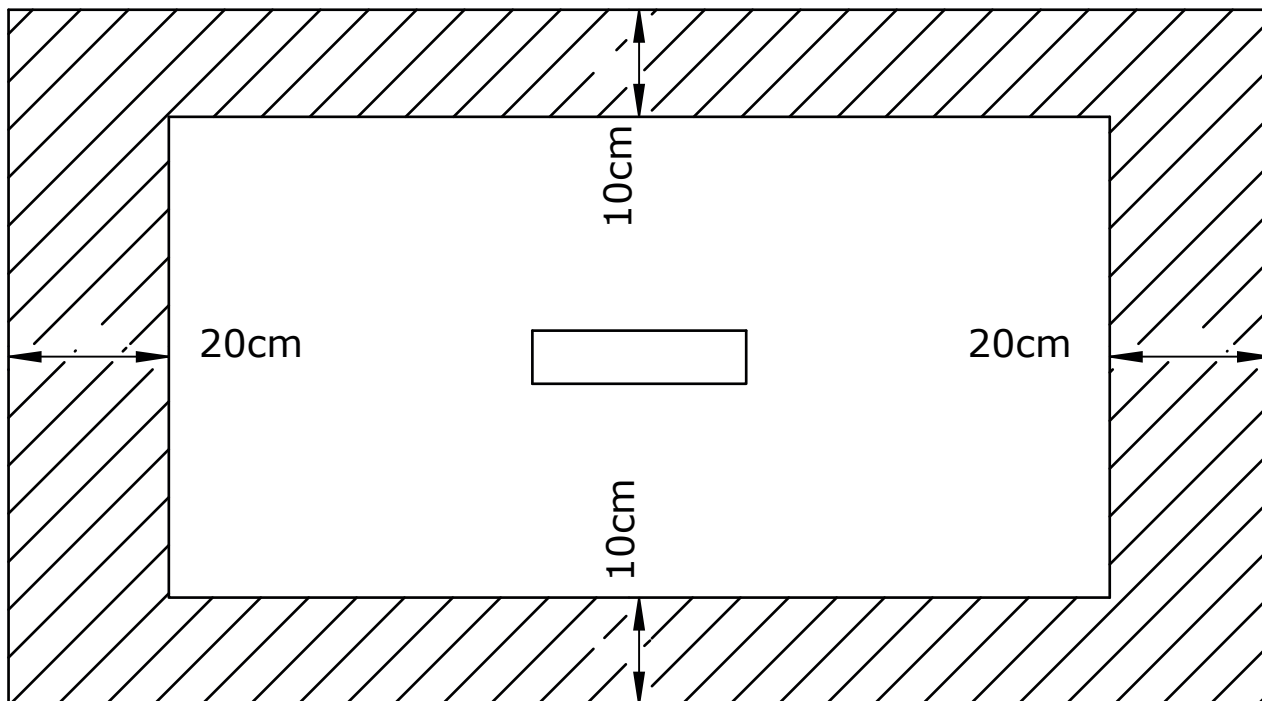

FR-Zone MAXI découpable
GB-MAX cuttable area
ES-Zona MAXIMA de recorte
PT-Límite MÁXIMO de corte
IT-Limite MASSIMO di taglio
NL-MAXIMAAL aanpasbaar deel
DE-MAXIMALER Schneidbereich

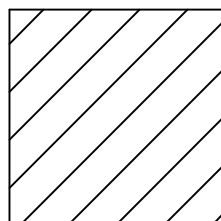

1

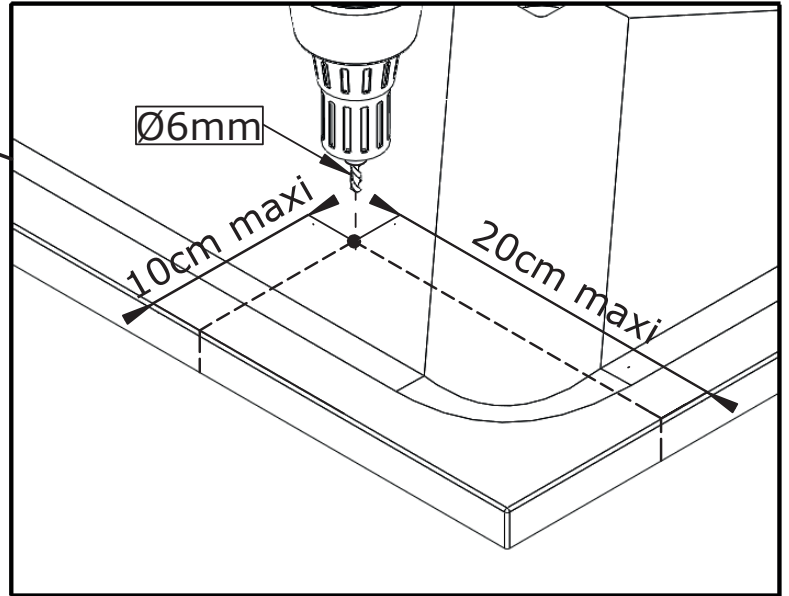
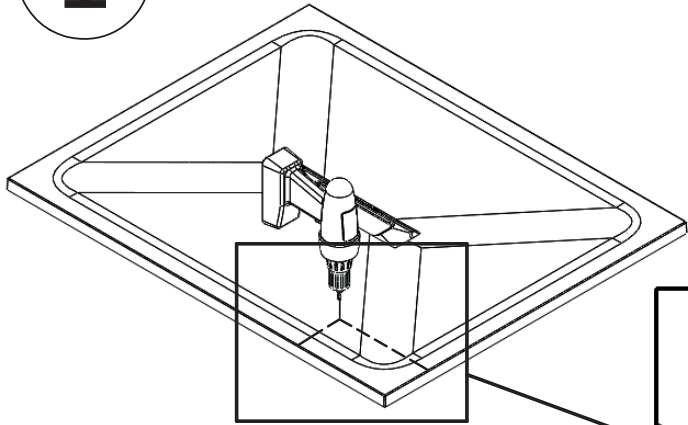

2

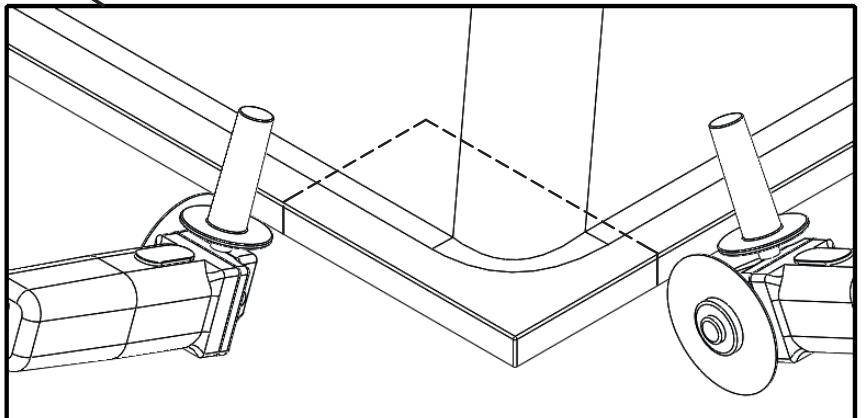
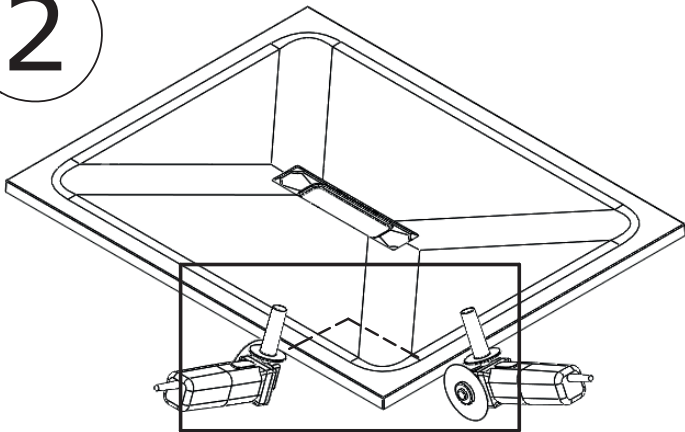

3



FR-Appliquer une couche de colle polyuréthane ou MS polymère à l'aide d'une spatule sur la surface coupée et combler l'espace entre les nervures du receveur avec une couche de mortier adhésif.

GB-Apply a polyurethan adhesive or MS polymer layer using a spatula over the raw surface and fill the space between the ribs of the tray with a layer of adhesive mortar.

ES-Aplicar una capa de pegamento poliuretano o polímero MS en la superficie recortada. Puede ayudarse de una espátula y rellenar los espacios huecos del plato con una capa de mortero adhesivo.

PT-Aplique uma camada de cola de poliuretano ou polímero MS na superfície cortada com uma espátula e preencha o espaço vazio da base com uma camada de argamassa selante.

IT-Applicare della colla poliuretanic o MS polimero con l'aiuto di una spatola sulla parte tagliato e compensare lo spazio tra le venature del piatto con uno strato di materiale adesivo.

NL-Breng met een spatel een laag polyurethaan lijm of MS polymeer lijm aan op de zaagranden, en vul de tussenliggende ruimte tot het steunoppervlak van de douchebak op met een laag cement.

DE-Wenn Sie ihre Duschtasse zuschneiden, müssen die Schnittkanten mittels Polyurethan- oder MS-Polymer-Klebstoff versiegelt werden. Tragen Sie die Versiegelung mit einem Spachtel auf der Schnittfläche bis unterhalb der Duschtasse auf.

FR-Colle polyuréthane/MS polymère

GB-Polyurethane adhesive/MS polymer

ES-Pegamento poliuretano/polimero MS

PT-Cola de poliuretano / polímero MS

IT-Colla poliuretanic/MS polimero

NL-Polyurethaan/MS polymeer lijm

DE-Schicht aus Polyurethan-/MS-Polymer-Klebstoff

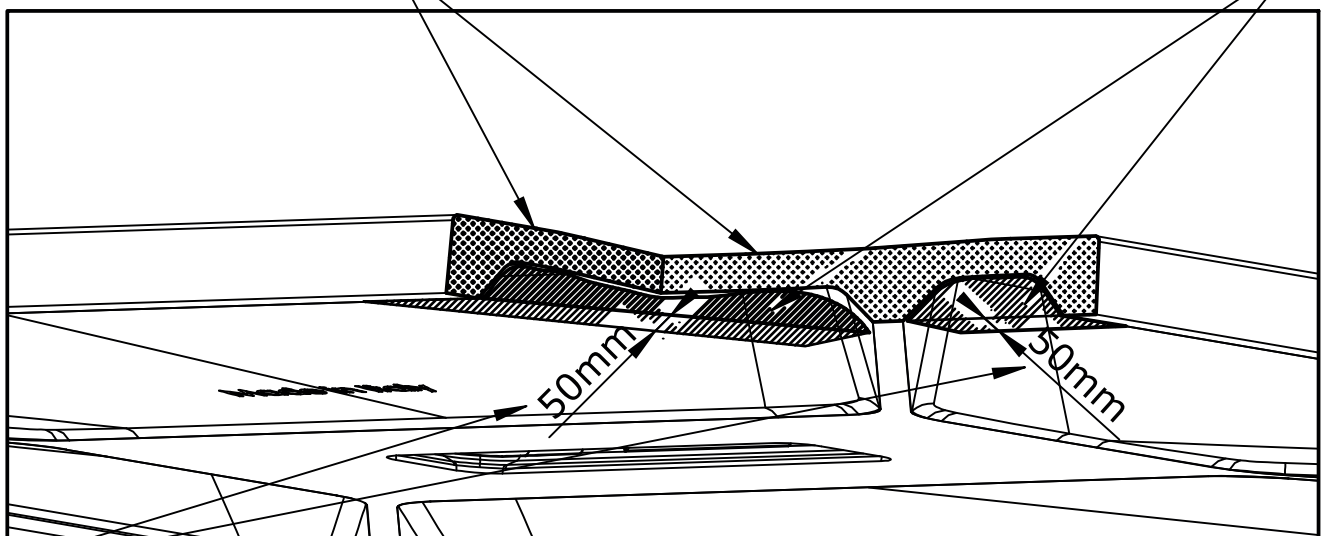
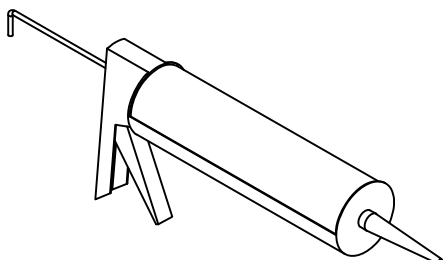

FR-Couche de 50mm de mortier adhésif **GB**-50mm layer of adhesive mortar

ES-Capa de 50mm de grosor de mortero adhesivo **PT**-Camada de 50mm de argamassa selante

IT-Strato di 50mm di materiale adesivo

NL-Laag van 50mm lijmmortel **DE**-50 mm x Schnittlänge mit Klebstoff auffüllen

FR-Nombre de pieds **GB**-Feet quantity **ES**-Cantidad de pies
PT-Quantidade de pés **IT**-Quantità di piedini **NL**-Hoeveelheid voeten
DE-Anzahl an FüÙe

REC664	70X70	4	REC673	110X70	8	REC682	140X80	10	REC691	160X90	10	REC700	200X100	14
REC665	75X75	4	REC674	110X80	8	REC683	140X90	10	REC692	160X100	12			
REC666	80X80	4	REC675	120X70	8	REC684	140X100	10	REC693	170X70	10			
REC667	90X70	4	REC676	120X80	8	REC685	150X70	10	REC694	170X80	10			
REC668	90X90	4	REC677	120X90	8	REC686	150X80	10	REC695	170X90	10			
REC669	100X70	4	REC678	120X100	8	REC687	150X90	10	REC696	180X80	12			
REC670	100X80	4	REC679	130X70	8	REC688	150X100	12	REC697	180X90	12			
REC671	100X90	4	REC680	130X80	8	REC689	160X70	10	REC698	180X100	14			
REC672	100X100	8	REC681	140X70	10	REC690	160X80	10	REC699	190X90	12			

FR-La distance bord à bord entre deux pieds ne doit pas être de plus de 30 cm.
 LES PIEDS DOIVENT ETRE INSTALLES SUR LES NERVURES DU RECEVEUR.

GB-The distance from the edge of the shower tray to the edge of a peripheral support should be no more than 30 cm.
 THE FEET MUST BE INSTALLED ON THE SHOWER TRAY RIBS.

ES-La distancia entre cada pie no debe superar los 30 cm.
 LOS PIES DEBEN ESTAR INSTALADOS SIGUIENDO LAS NERVIOS DEL PLATO.

PT-A distância entre dois pé não deve exceder 30cm.
 OS PÉS DEVEM SER INSTALADOS NAS NERVURAS DA BASE.

IT-La distanza tra due piedi non dovrebbe essere superiore a 30 cm.
 I PIEDI DEVONO ESSERE INSTALLATI SULLE NERVATURE DEL PIATTO DOCCIA.

NL-De afstand tussen twee stelpoten mag niet meer dan 30 cm bedragen.
 DE STELPOTEN DIENEN OP HET STEUNOPPERVLAK VAN DE DOUCHEBAK GEÏNSTALLEERD TE WORDEN.

DE-Der Abstand zwischen zwei verstellbaren FüÙen darf 30 cm nicht überschreiten.
 DIE FÜÙE MÜSSEN AUF DEN TRÄGERN DER DUSCHTASSE MONTIERT WERDEN.

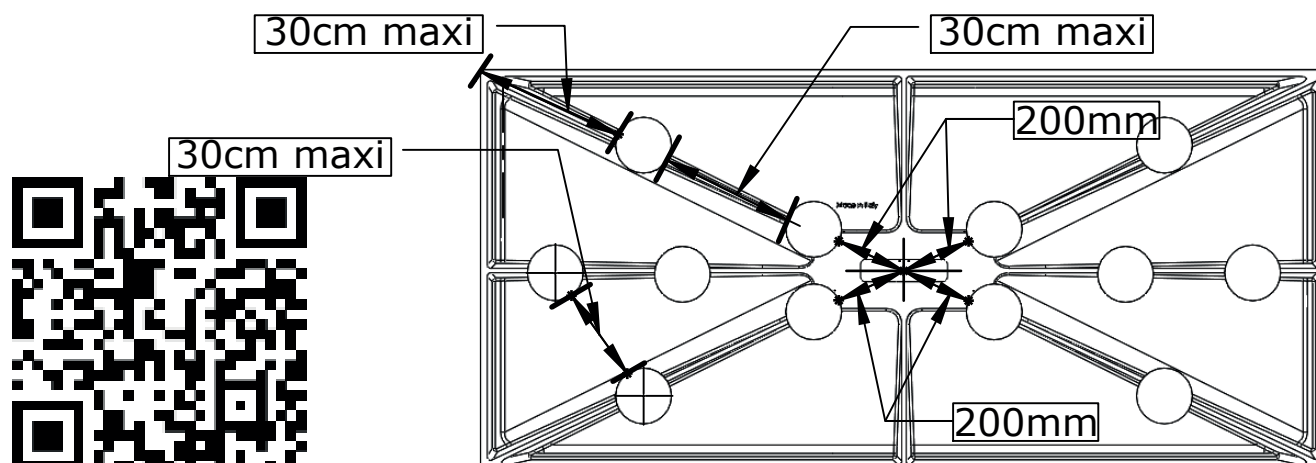

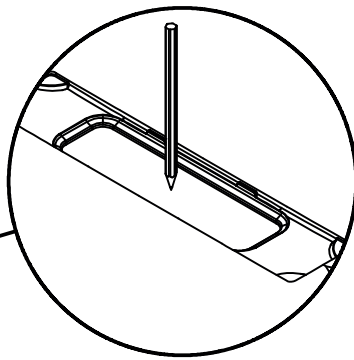
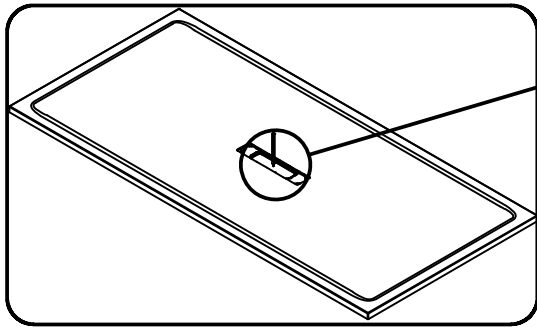

Tracer la position de la bonde et réaliser un montage à blanc de la bonde et du receveur

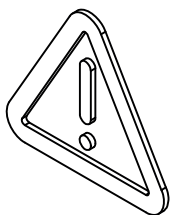
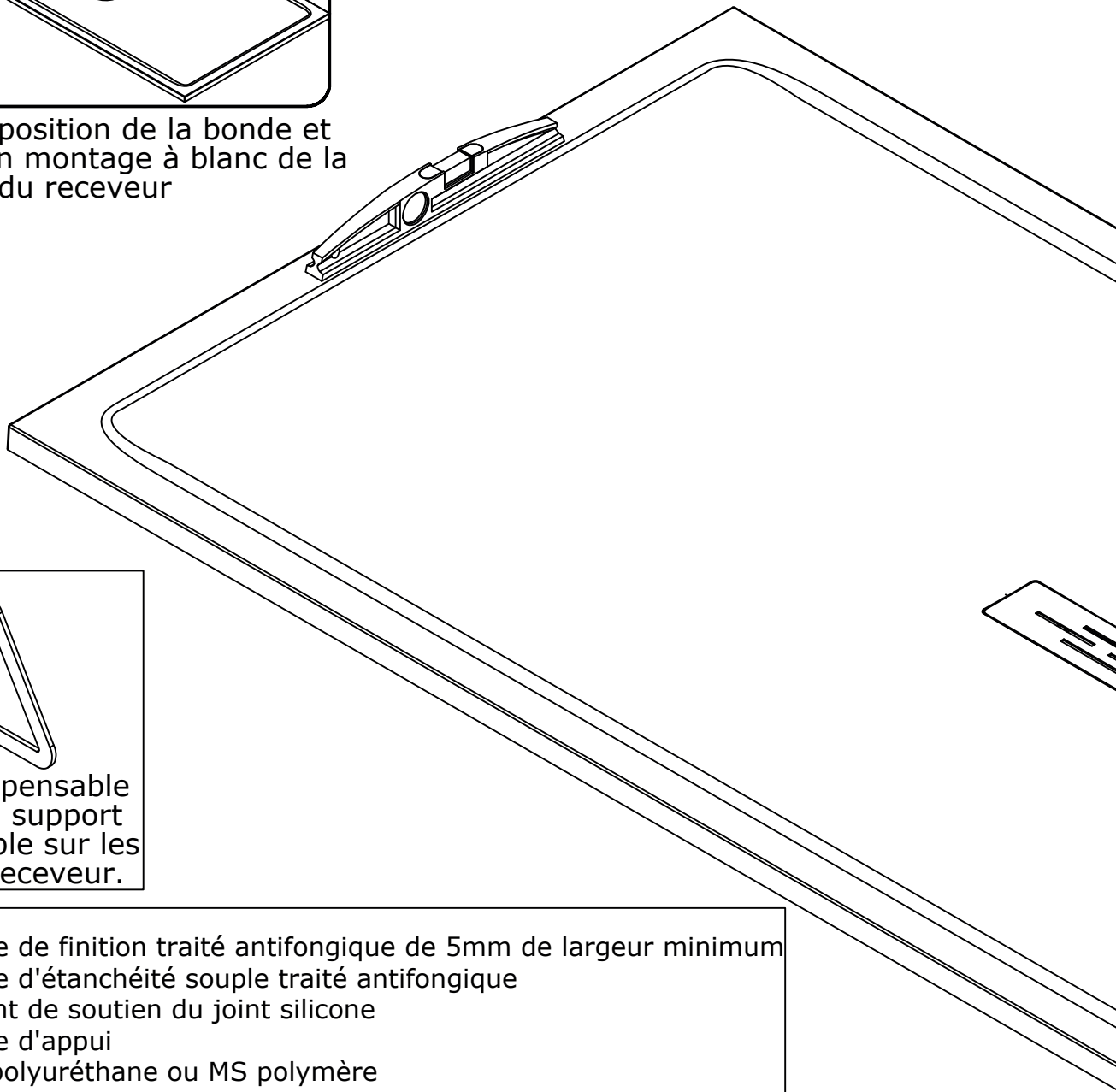

Il est indispensable d'avoir un support imputrescible sur les côtés du receveur.

- ① - silicone de finition traité antifongique de 5mm de largeur minimum
- ② - silicone d'étanchéité souple traité antifongique
- ③ - élément de soutien du joint silicone
- ④ - silicone d'appui
- ⑤ - colle polyuréthane ou MS polymère

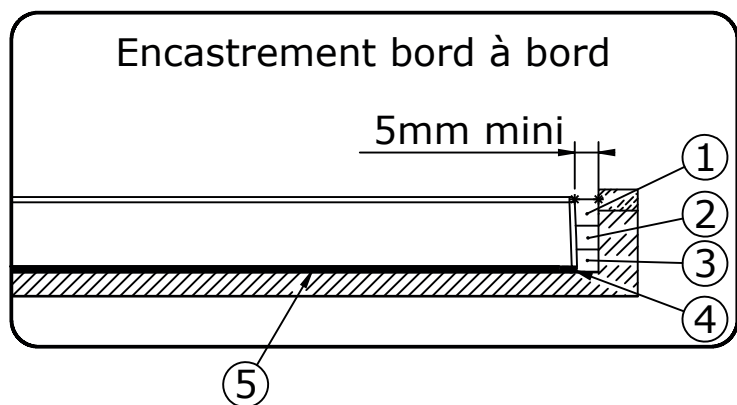
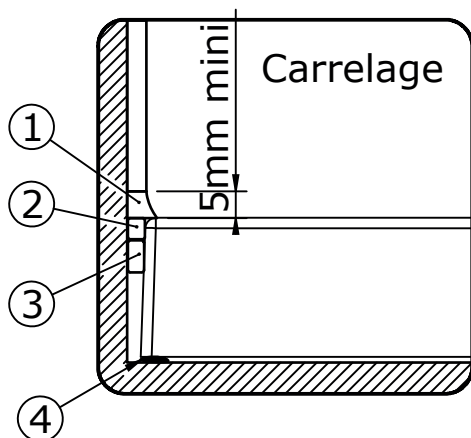



Pendant toute la durée des travaux, protéger le receveur contre toute agression : brûlures, chocs, rayures, décapants...



Le montage d'une soupape anti-vidé est nécessaire pour une utilisation optimale si un autre appareil sanitaire est raccordé sur la même évacuation.

Ne pas utiliser d'acide chlorhydrique ni de dégraissant puissant

Pose directe au sol

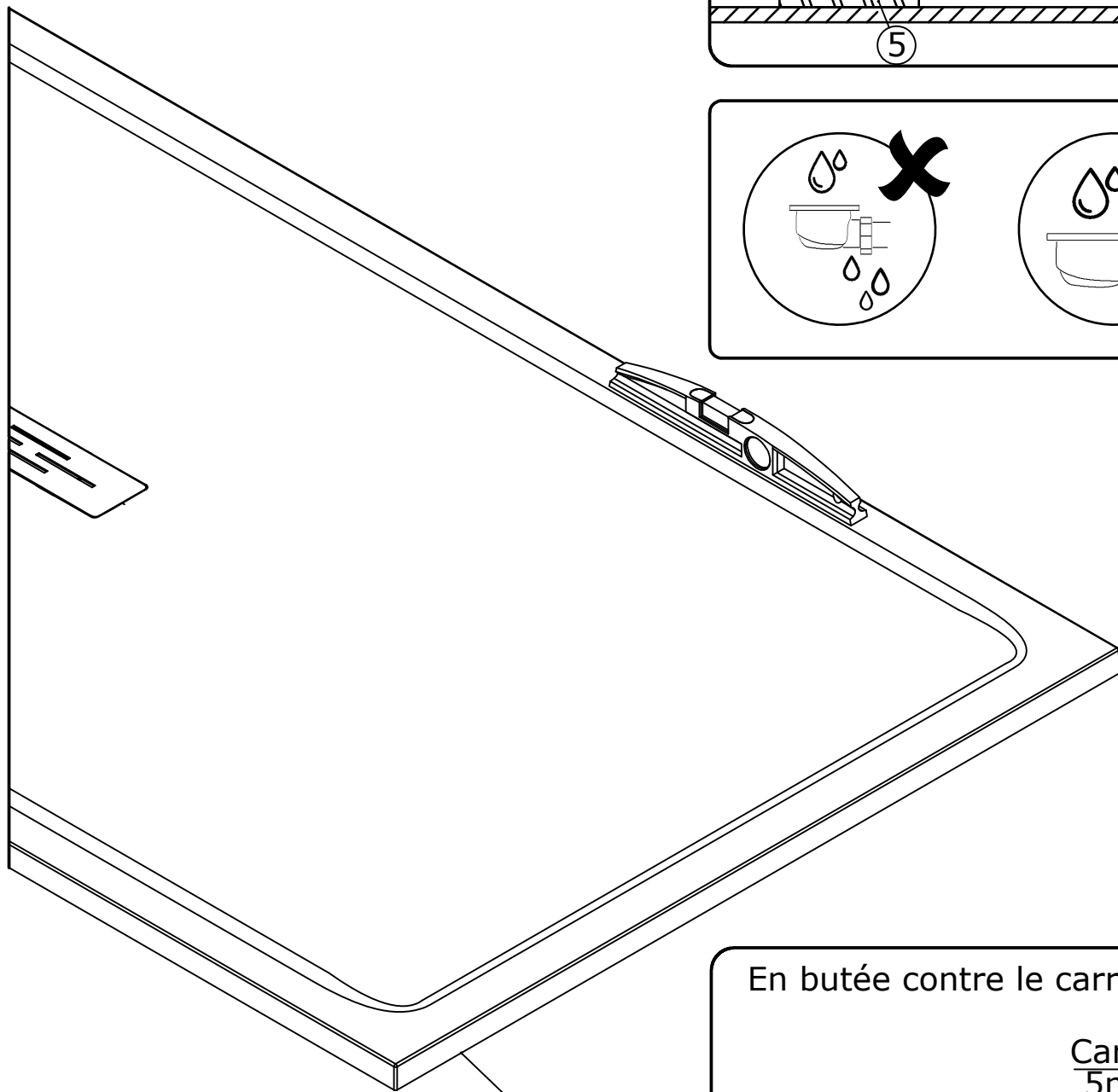
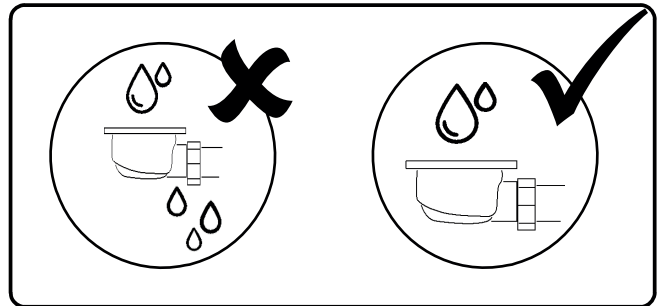
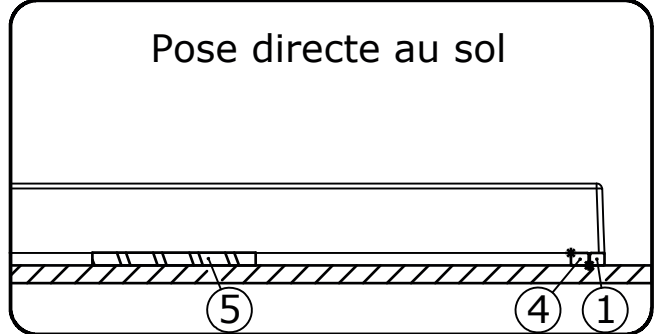

Sol rigide, plan et non humide indispensable

En butée contre le carrelage

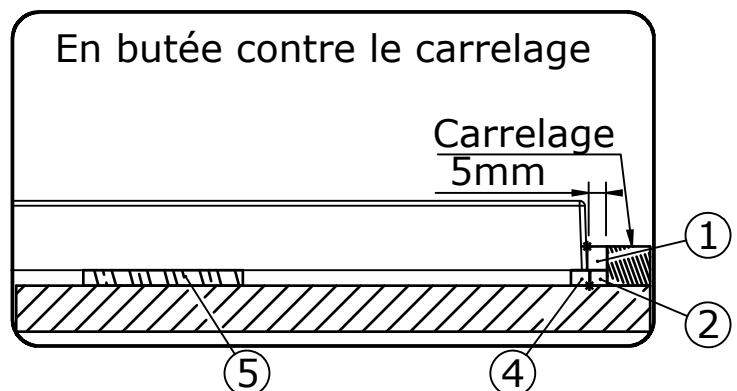

X	Y	C	D
80	80	32	27
90	90	37	32
100	100	42	32
100	80	32	37
100	90	37	37
120	80	32	47
120	90	37	47
120	100	42	47
140	80	32	57
140	90	37	57
140	100	42	57
160	80	32	67
160	90	37	67
160	100	42	67
180	80	32	77
180	90	37	77
180	100	42	77

KINEMOON STYLE

TYPES D'INSTALLATION

1. Posé sur pieds réglables avec habillage carrelé

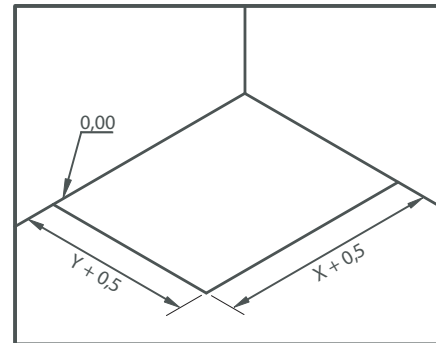
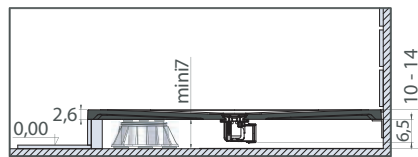
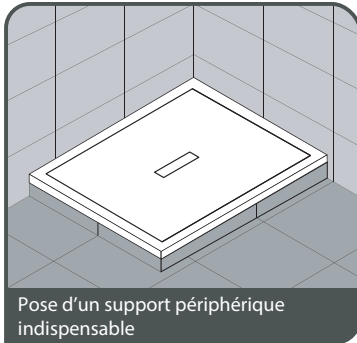

Préparation de l'implantation

2. Posé en butée contre le carrelage

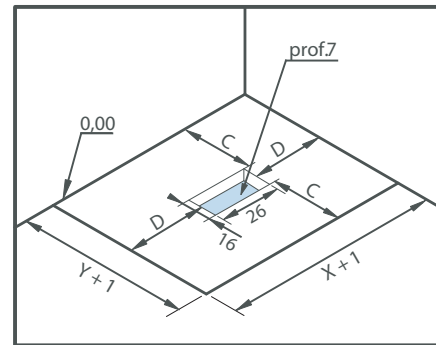
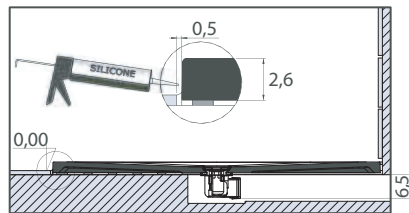
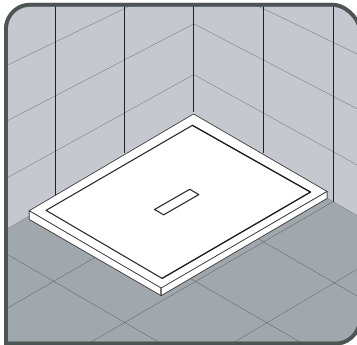

Préparation de l'implantation

3. Encastré et posé sur pieds réglables

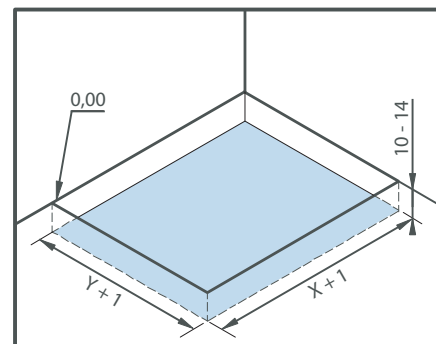
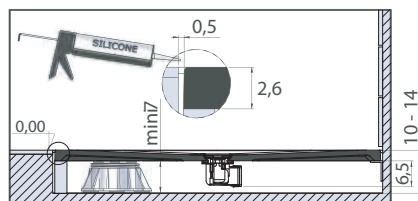
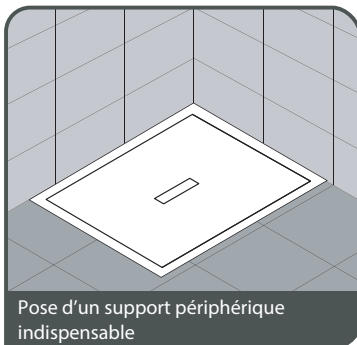

Préparation de l'implantation

4. Encastré et posé sans pieds réglables

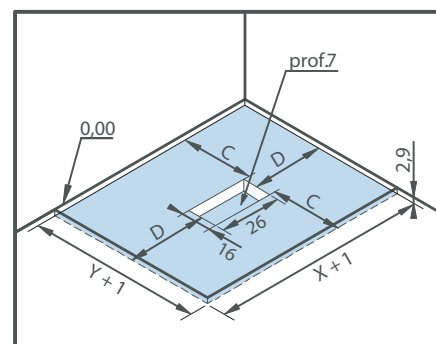
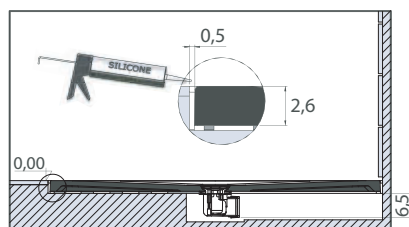
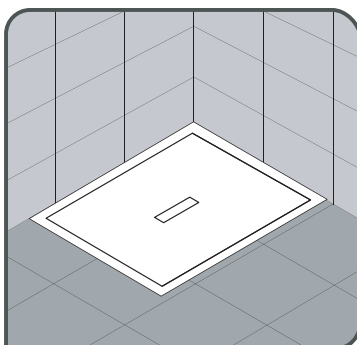

Préparation de l'implantation

GB

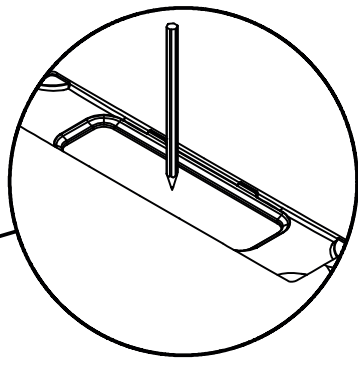
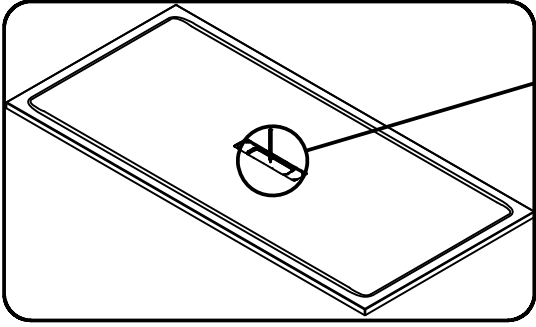

Mark the position of the waste and test-assemble the tray and waste

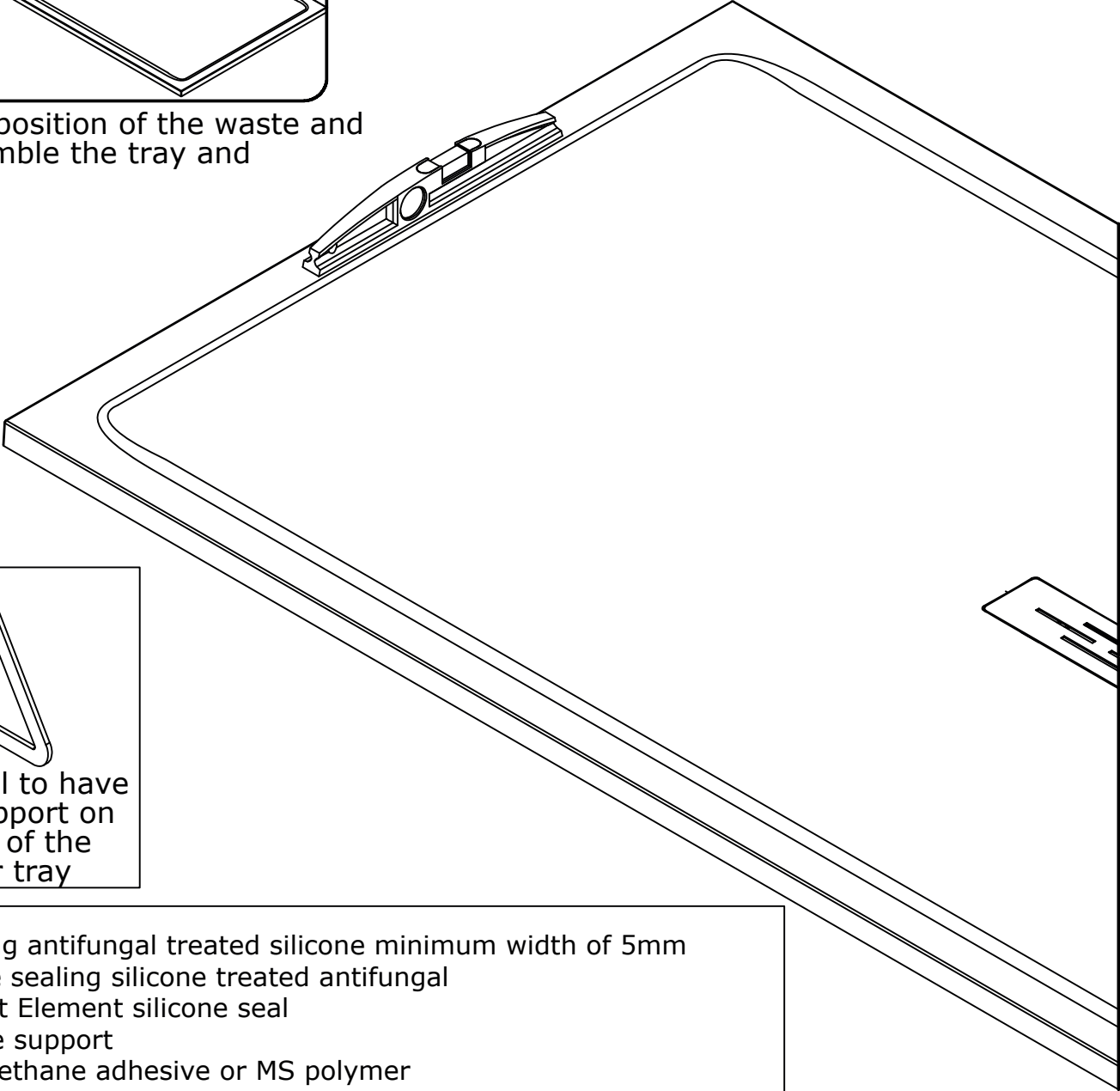

- ① - finishing antifungal treated silicone minimum width of 5mm
- ② - flexible sealing silicone treated antifungal
- ③ - support Element silicone seal
- ④ - silicone support
- ⑤ - polyurethane adhesive or MS polymer

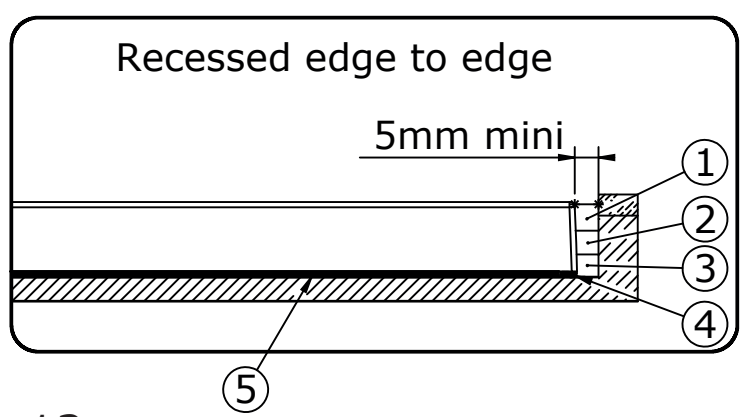
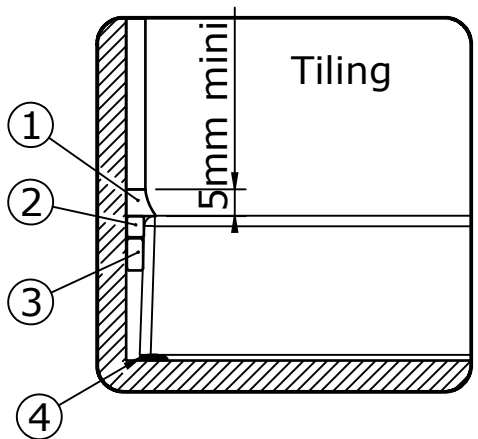

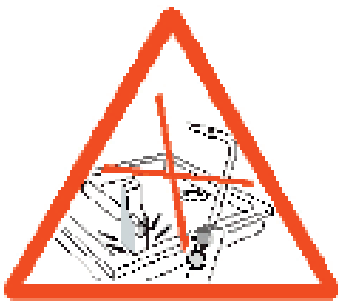

Throughout the protect the tray of the work, protect the recipient against any aggression: burns, shock, scratches, strppers...



The installation of an anti-vacuum valve is necessary for optimal use if another appliance is connected to the same discharge pipe

Do not use hydrochloric acid or powerful degreaser

Direct floor installation

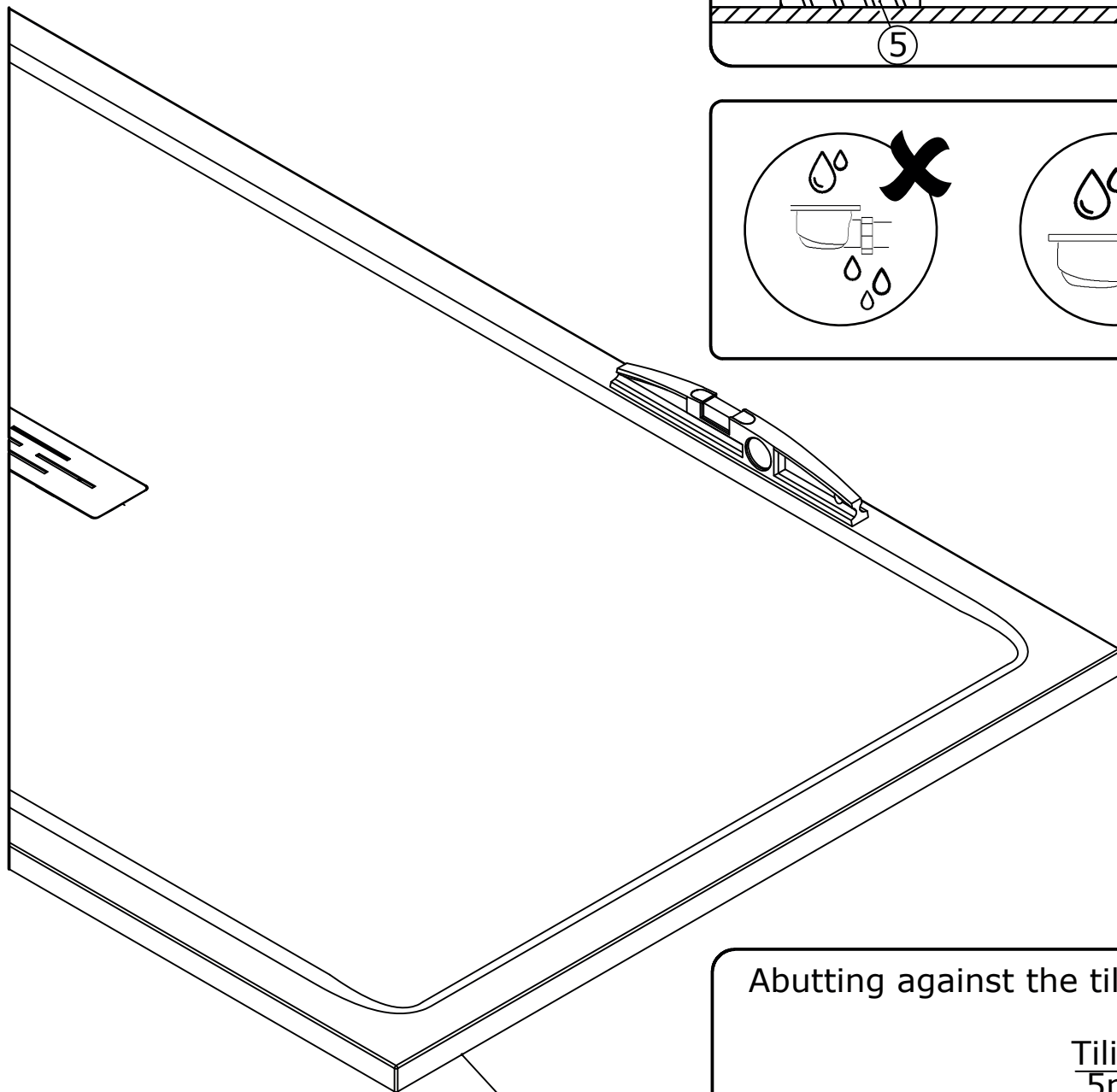
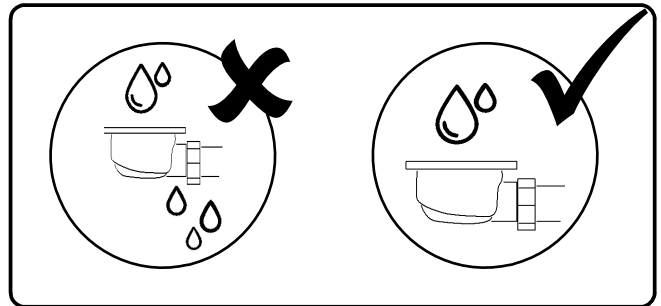
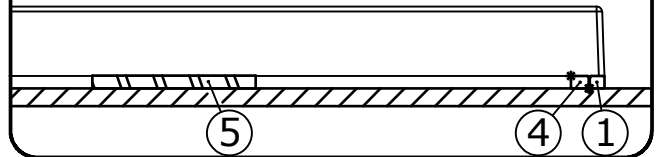

The base must be rigid, flat and dry

Abutting against the tile

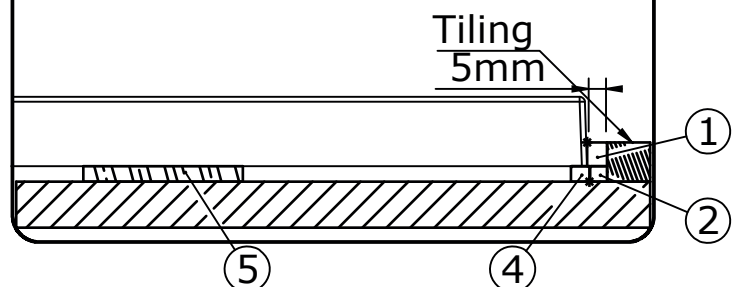

X	Y	C	D
80	80	32	27
90	90	37	32
100	100	42	32
100	80	32	37
100	90	37	37
120	80	32	47
120	90	37	47
120	100	42	47
140	80	32	57
140	90	37	57
140	100	42	57
160	80	32	67
160	90	37	67
160	100	42	67
180	80	32	77
180	90	37	77
180	100	42	77

KINEMOON STYLE

INSTALLATION TYPES

1. Mounted on adjustable legs with cladding

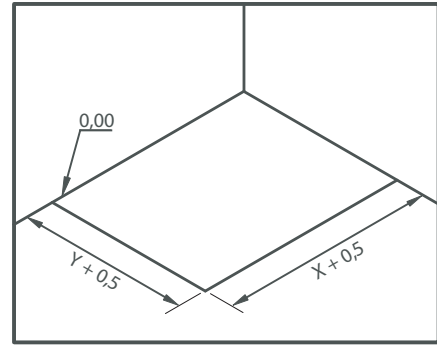
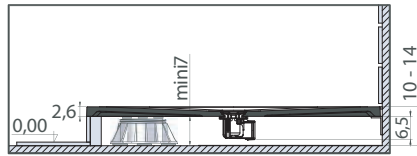
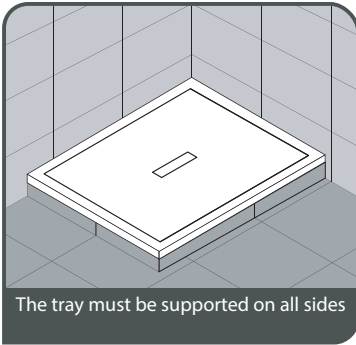

Pre-installation

2. Installed in abutment against the tile

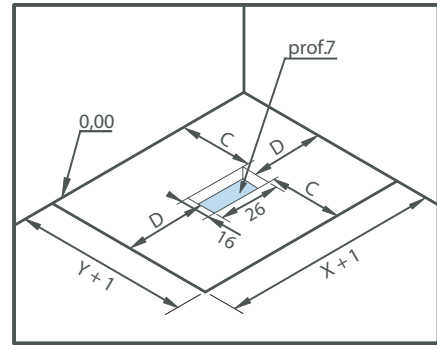
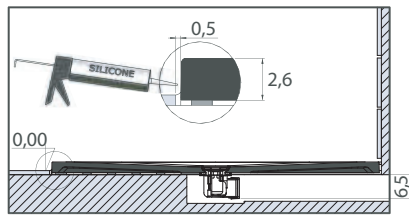
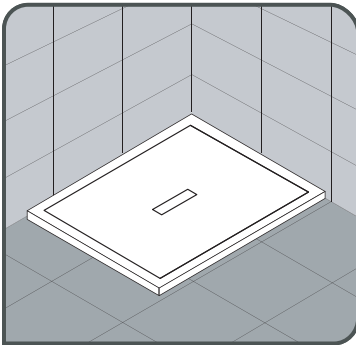

Pre-installation

3. Built-in and placed on adjustable legs

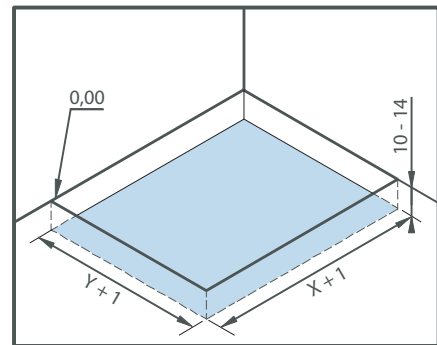
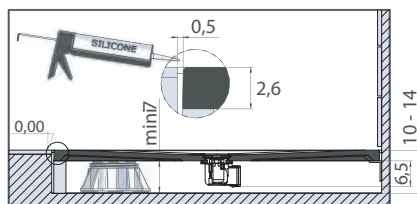
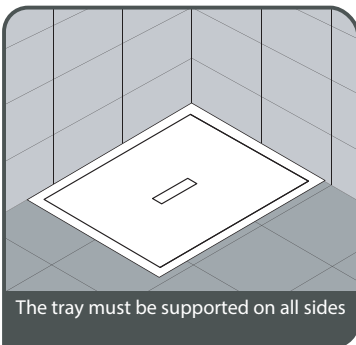

Pre-installation

4. Built-in and installed without adjustable feet

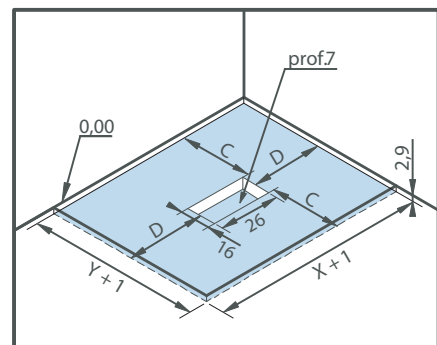
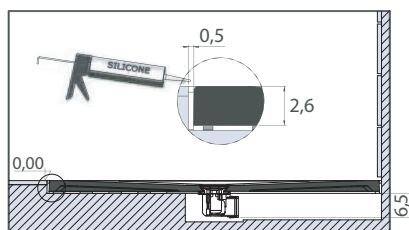
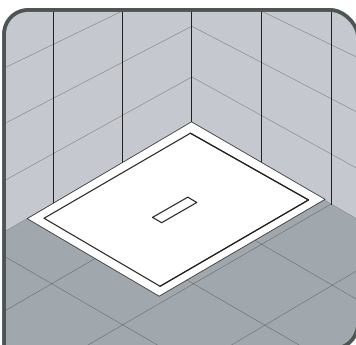

Pre-installation

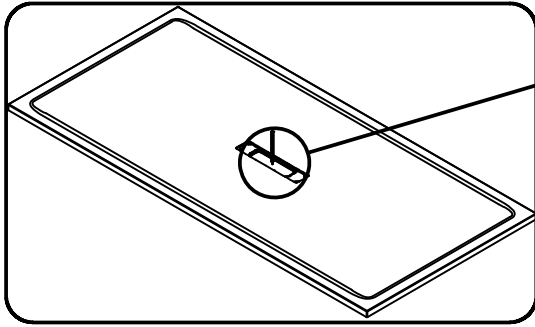

Marcar la ubicación del desagüe y montarlo con el plato para comprobar su correcta ubicación.



- ① - silicona de acabado tratada antihongos
- ② - silicona de estanqueidad, blanda, tratada antihongos
- ③ - soporte de la junta de silicona
- ④ - silicona de apoyo
- ⑤ - pegamento poliuretano o polímero MS

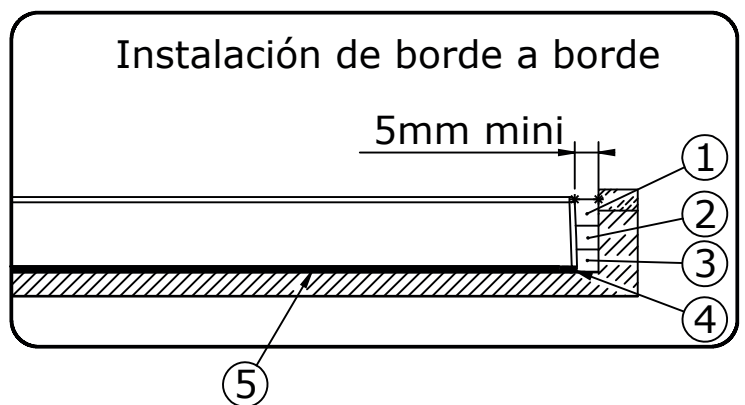
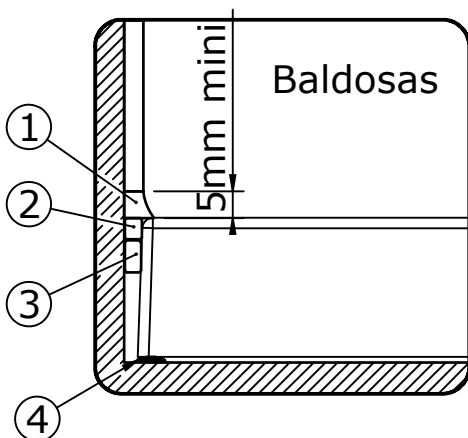

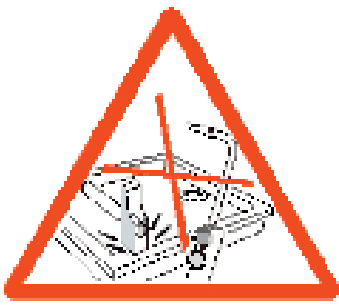

Durante las obras proteger el plato de golpes, quemaduras, rayaduras, etc...



La instalación de un venteo es necesaria si otro aparato está conectado al mismo recorrido de evacuación.

No utilizar ácido clorhídrico o No utilizar ácido clorhídrico

Instalación directa al suelo

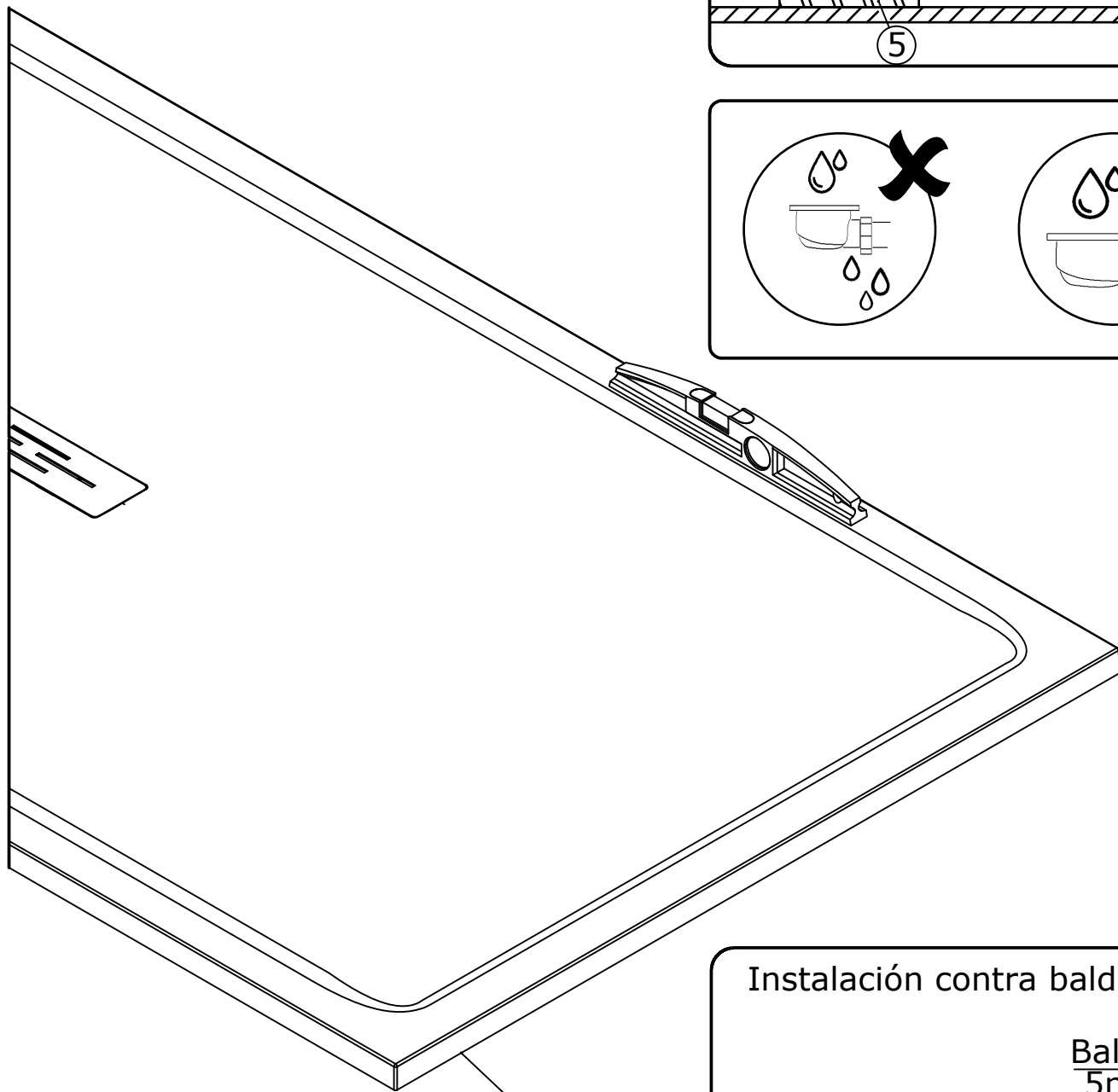
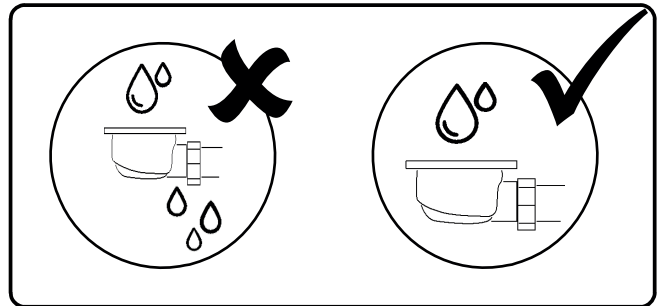
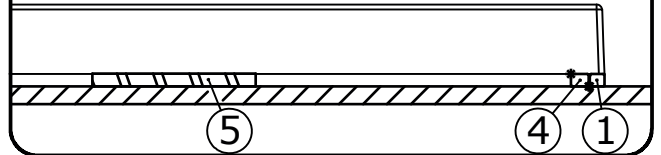

Suelo rígido, plano y seco indispensable

Instalación contra baldosas

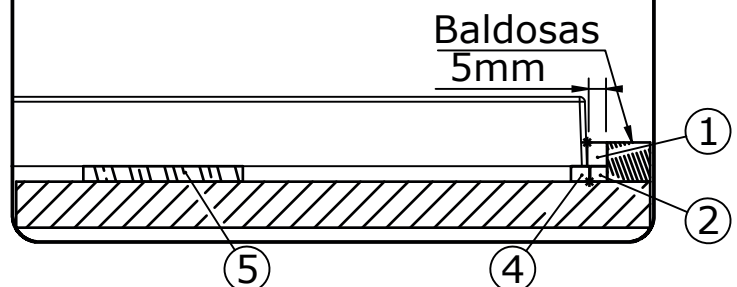

X	Y	C	D
80	80	32	27
90	90	37	32
100	100	42	32
100	80	32	37
100	90	37	37
120	80	32	47
120	90	37	47
120	100	42	47
140	80	32	57
140	90	37	57
140	100	42	57
160	80	32	67
160	90	37	67
160	100	42	67
180	80	32	77
180	90	37	77
180	100	42	77

KINEMOON STYLE

TIPOS DE INSTALACIÓN

1. Instalado sobre pies ajustables con revestimiento de baldosas

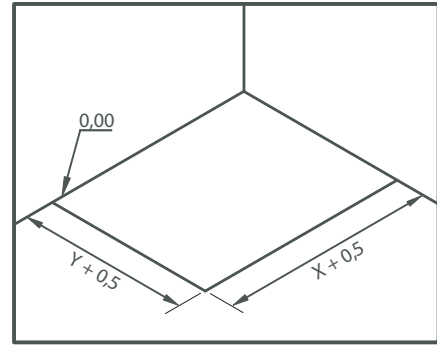
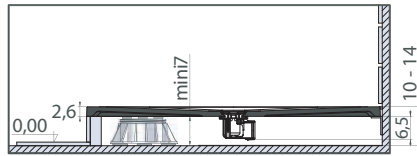

Preparación de la instalación

2. Colocación sobre suelo

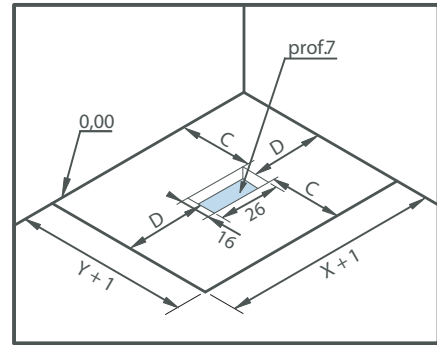
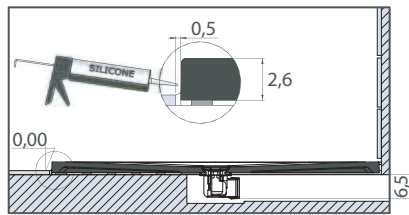
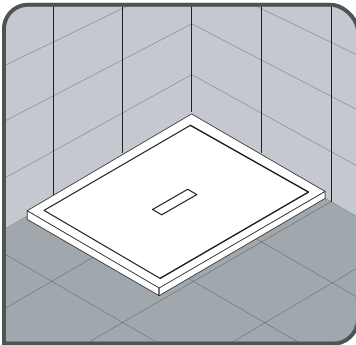

Preparación de la instalación

3. Instalación a ras de suelo, colocado sobre pies ajustables

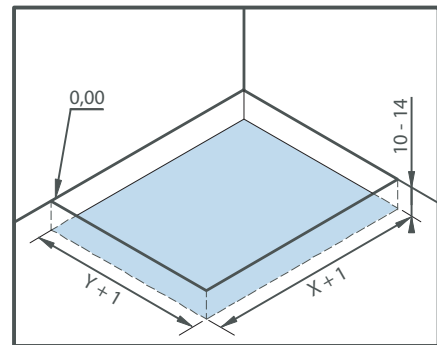
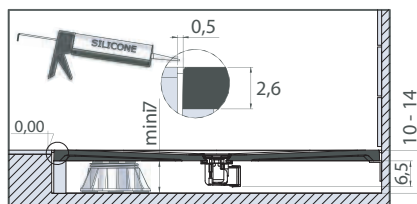

Preparación de la instalación

4. Instalación a ras de suelo, sin pies ajustables

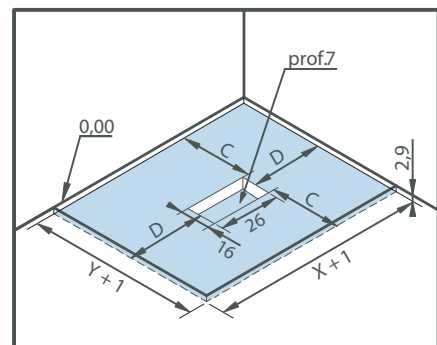
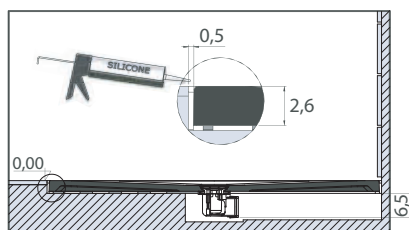
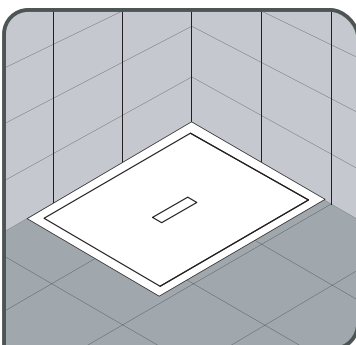

Preparación de la instalación

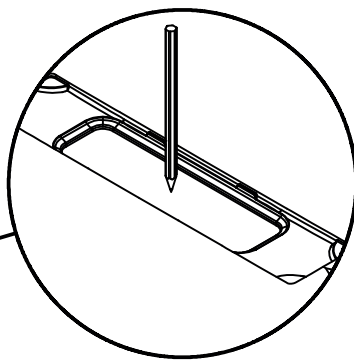
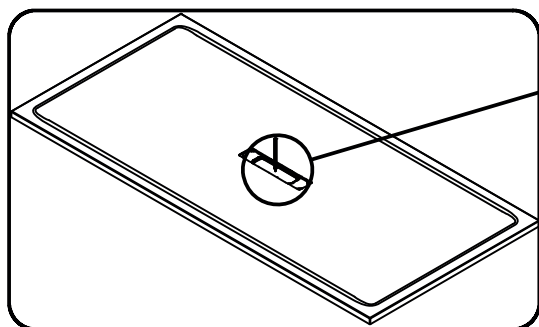

Marcar a localização da válvula e colocar a válvula na base para verificar se a localização é a correta.



É indispensável ter um apoio imputrescível nas laterais da base.

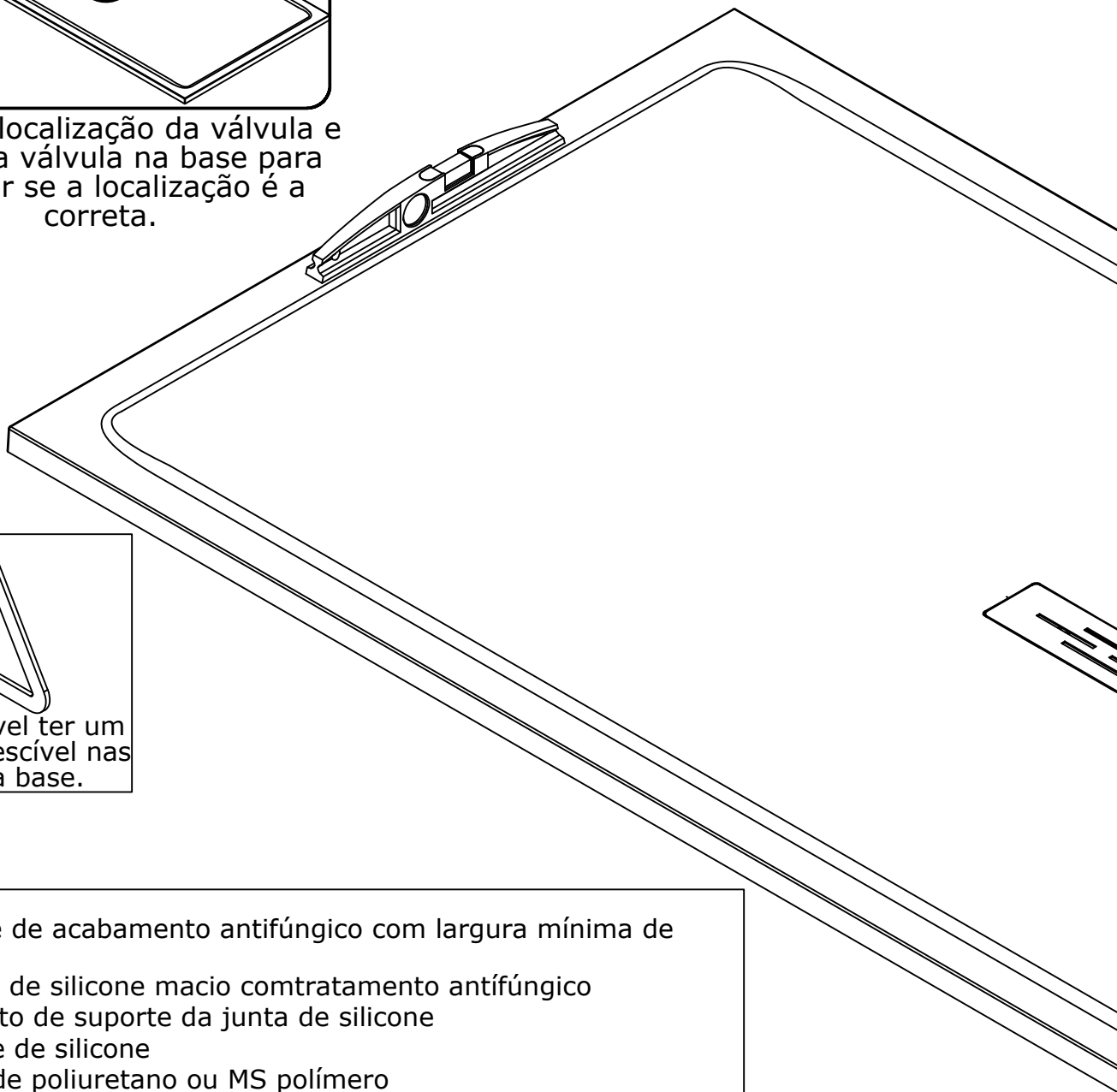

- ① - Silicone de acabamento antifúngico com largura mínima de 5mm
- ② - Selante de silicone macio com tratamento antifúngico
- ③ - Elemento de suporte da junta de silicone
- ④ - Suporte de silicone
- ⑤ - pCola de poliuretano ou MS polímero

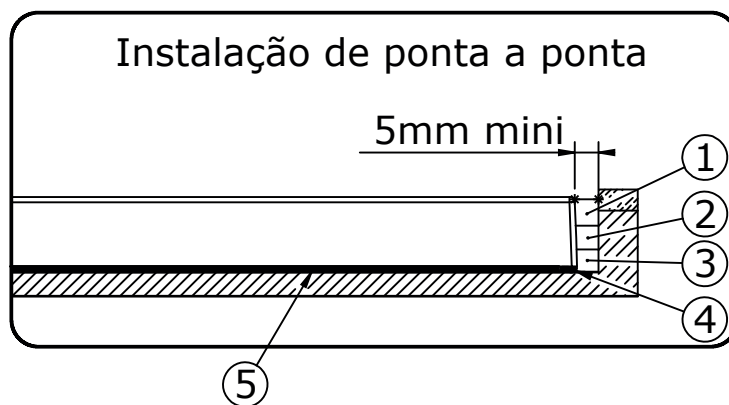
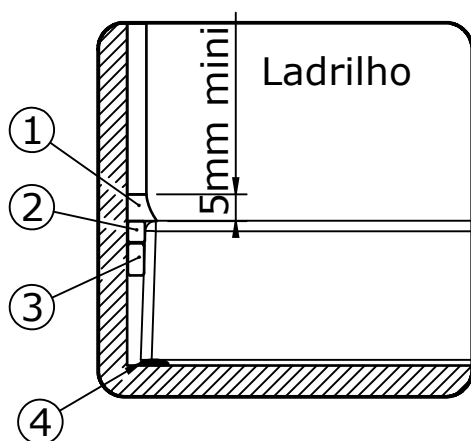



Durante toda a duração obras, proteger o receptor contra todos agressão: queimaduras, choques, arranhões, removedores...



Instalação de uma válvula anti-vácuo é necessário para uso ideal se outro dispositivo sanitário está conectado ao mesmo evacuação.

Não use ácido clorídrico ou poderoso desengordurante

Instalação direta no piso

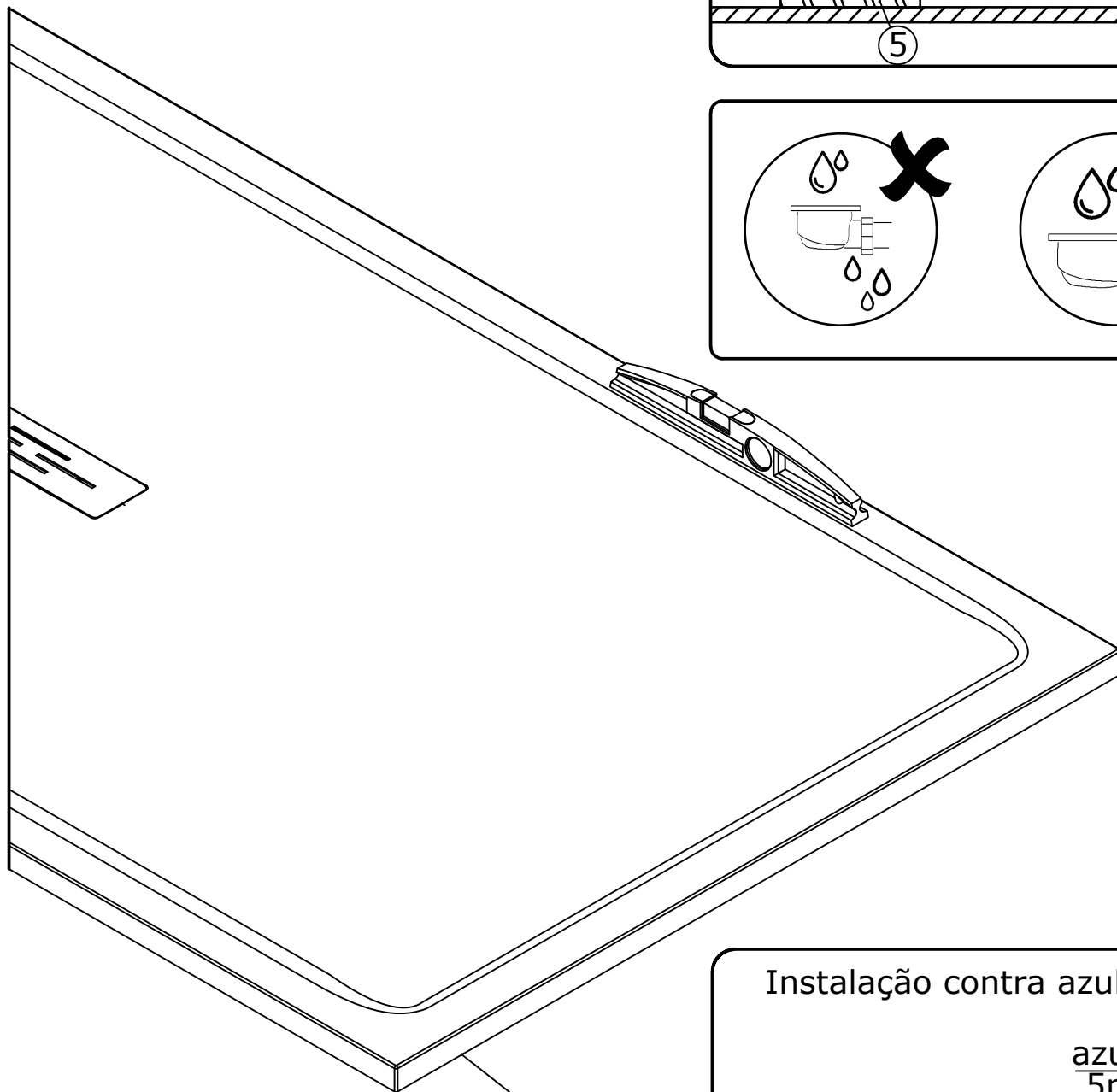
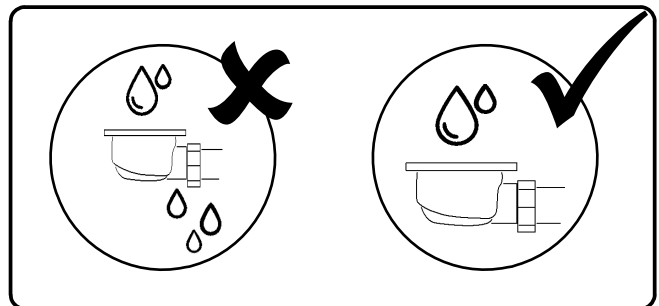
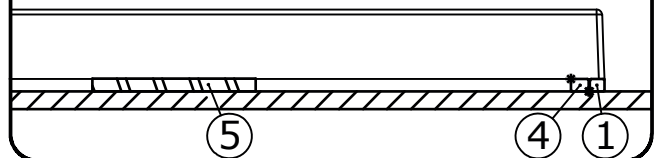

Piso rígido, nivelado e não molhado essencial

Instalação contra azulejos

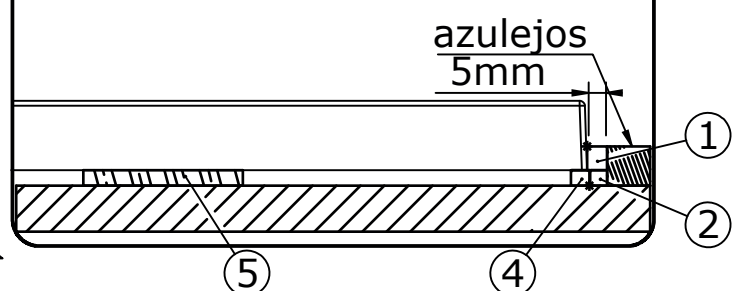

X	Y	C	D
80	80	32	27
90	90	37	32
100	100	42	32
100	80	32	37
100	90	37	37
120	80	32	47
120	90	37	47
120	100	42	47
140	80	32	57
140	90	37	57
140	100	42	57
160	80	32	67
160	90	37	67
160	100	42	67
180	80	32	77
180	90	37	77
180	100	42	77

KINEMOON STYLE

TIPOS DE INSTALAÇÃO

1. Pousado sobre pés ajustáveis com acabamento de azulejos

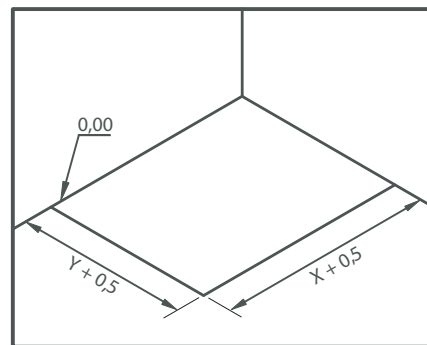
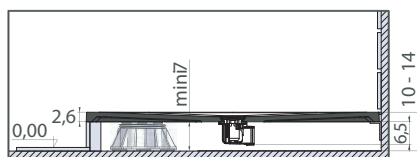

Preparação da instalação

2. Instalado sobre os azulejos

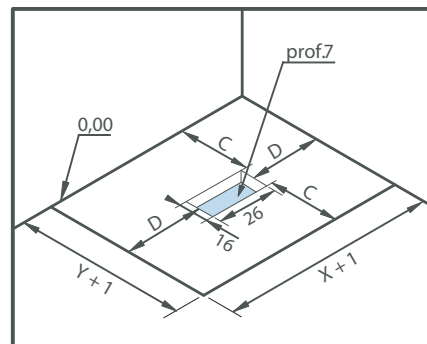
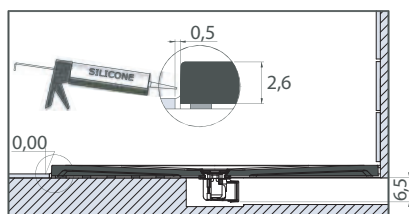
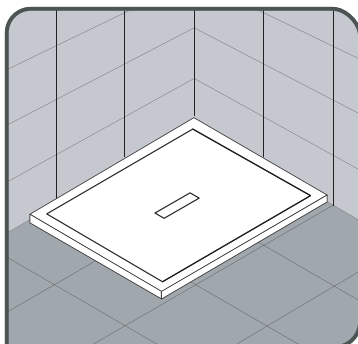

Preparação da instalação

3. Encastrado e colocado sobre pés ajustáveis

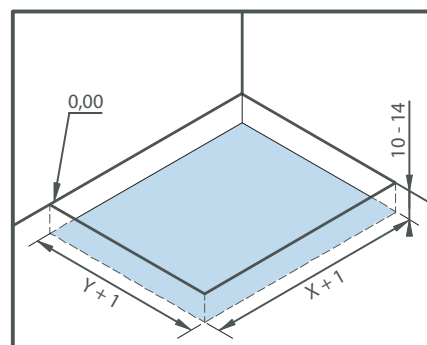
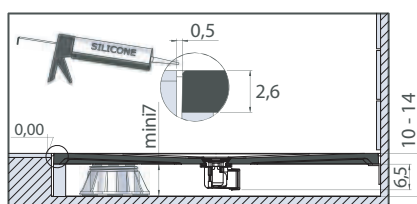

Preparação da instalação

4. Encastrado sem pés ajustáveis

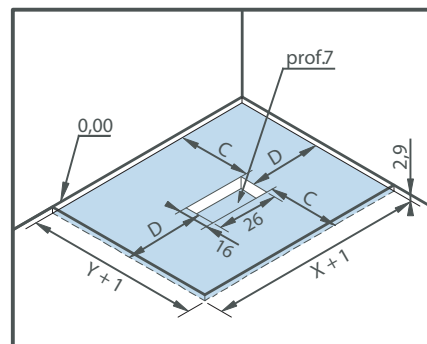
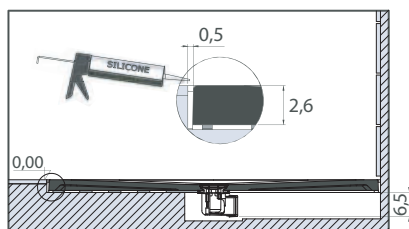
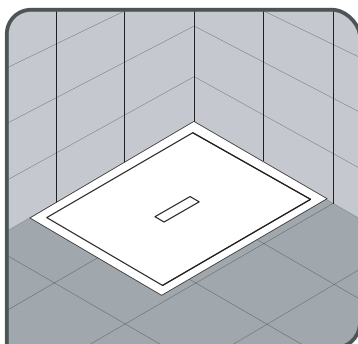

Preparação da instalação

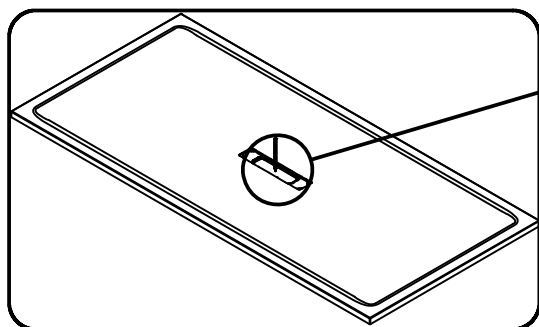

Tracciare la posizione dello scarico e realizzare un montaggio a vuoto dello scarico e del piatto



- ① - silicone di finitura antimuffa 5mm minimo
- ② - silicone di tenuta antimuffa
- ③ - elemento di tenuta del silicone
- ④ - supporto in silicone
- ⑤ - colla poliuretanica o MS polimero

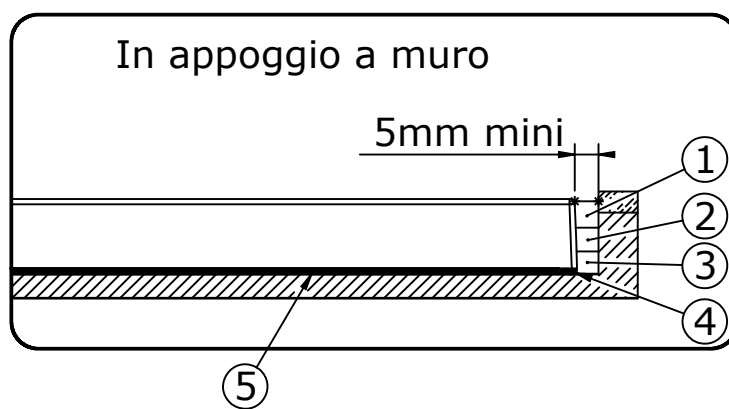
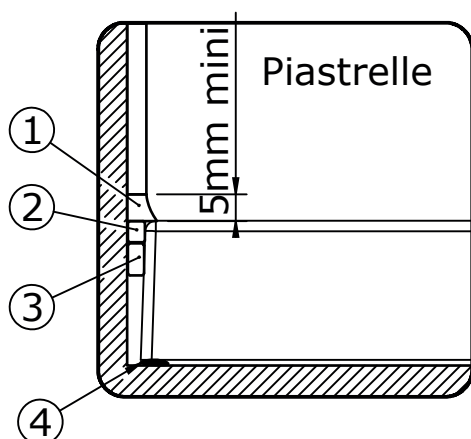

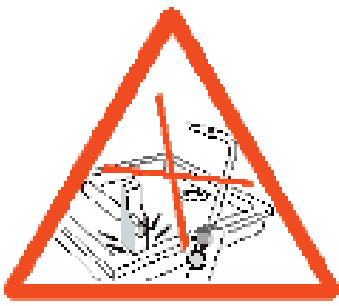

Durante la posa proteggere il piatto da graffi, colpi, attrezzi, bruciature ...



Il montaggio di una valvola di sicurezza è richiesto per un uso ottimale se un altre utenze sono collegate allo stesso scarico.

Non utilizzare acido cloridrico o forti sgrassatori

Posa diretta al suolo

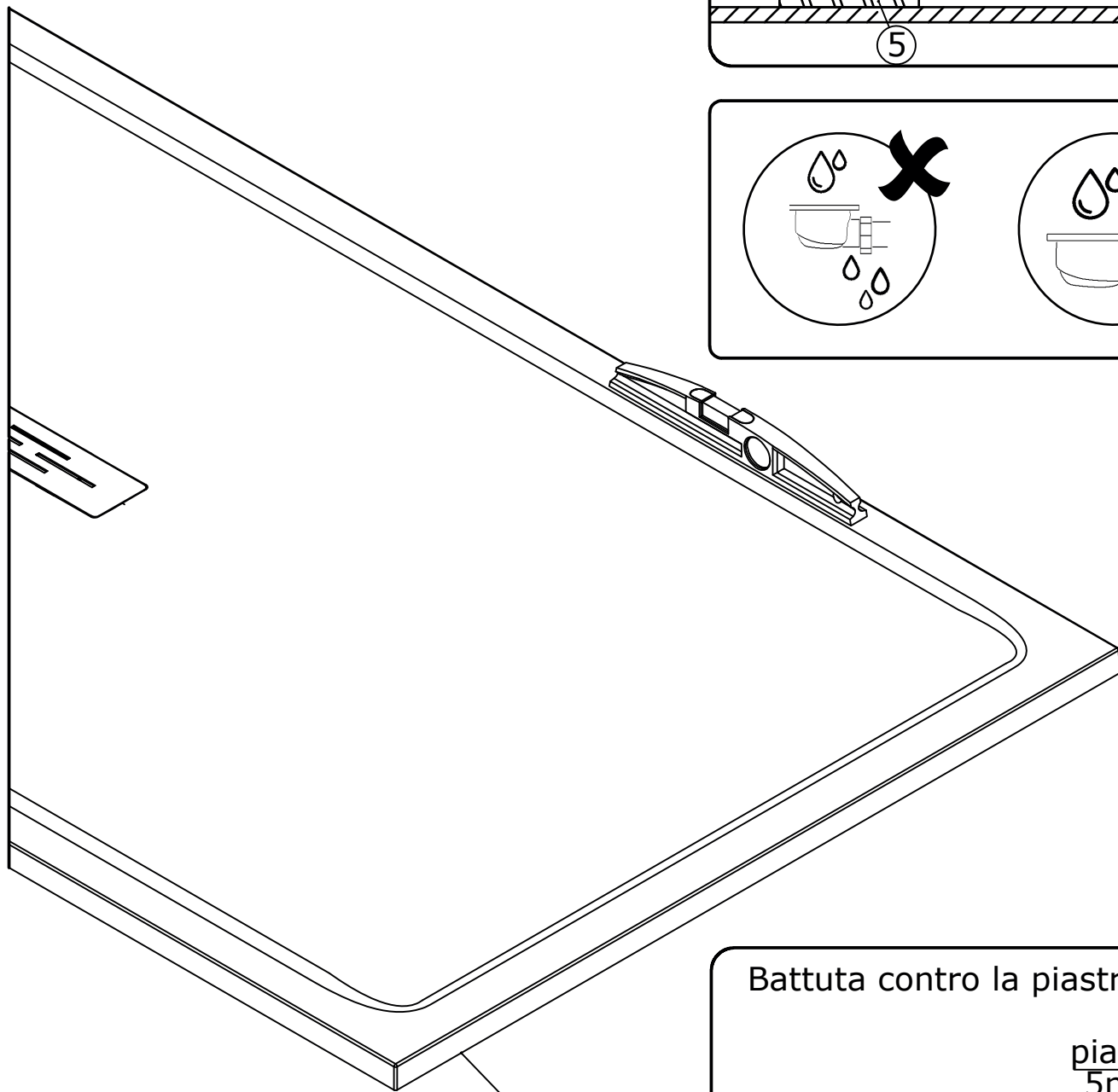
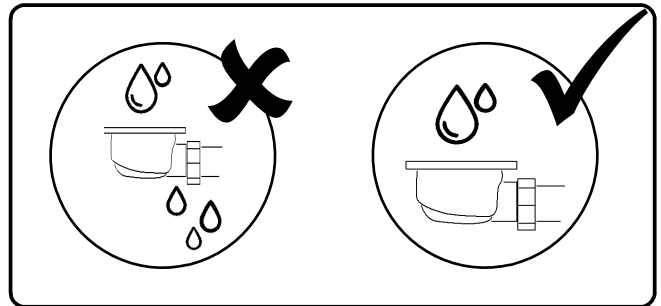
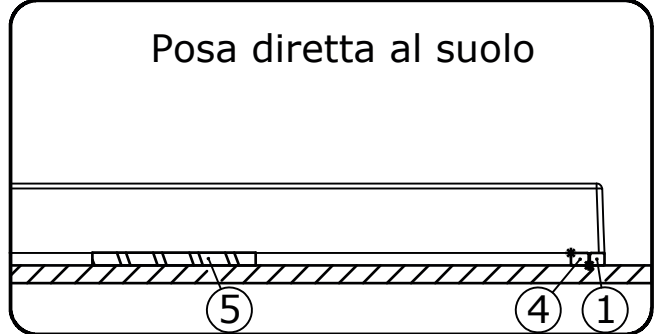

Suolo robusto e non umido

Battuta contro la piastrella

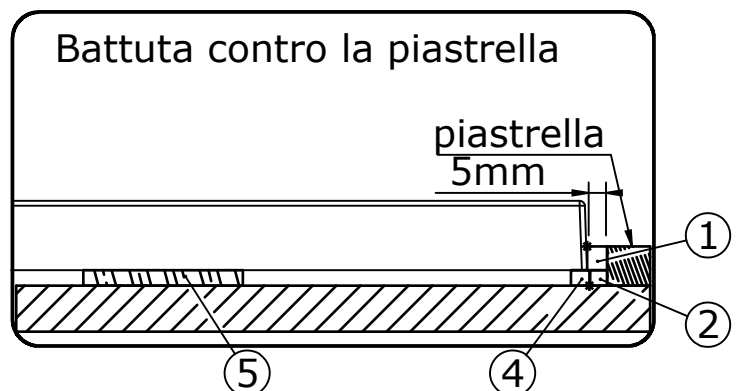

X	Y	C	D
80	80	32	27
90	90	37	32
100	100	42	32
100	80	32	37
100	90	37	37
120	80	32	47
120	90	37	47
120	100	42	47
140	80	32	57
140	90	37	57
140	100	42	57
160	80	32	67
160	90	37	67
160	100	42	67
180	80	32	77
180	90	37	77
180	100	42	77

KINEMOON STYLE

TIPI DI INSTALLAZIONE

1. Montato su piedini regolabili con rivestimento in piastrelle

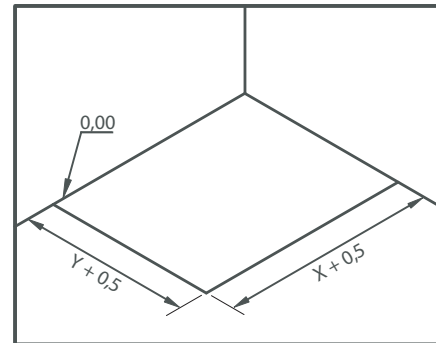
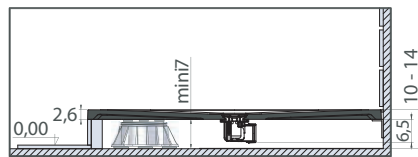

Predisposizione impianto

2. Installato in appoggio a pavimento

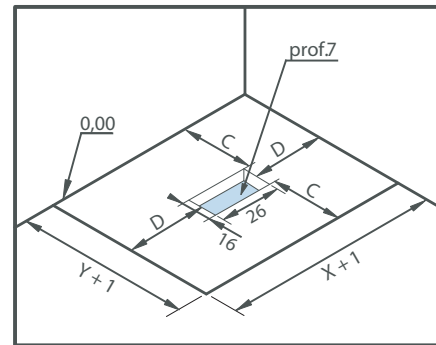
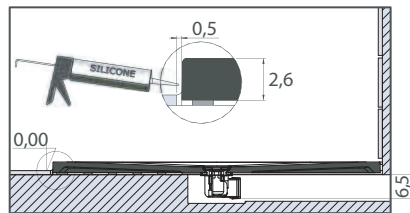
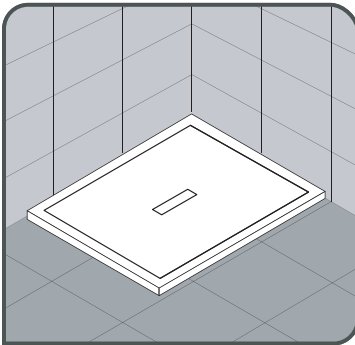

Predisposizione impianto

3. Incassato e posizionato su piedini regolabili

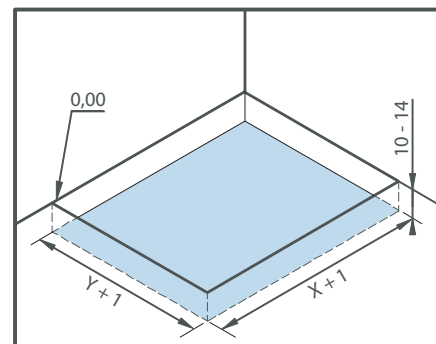
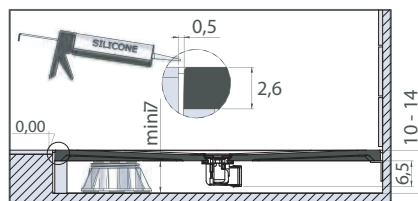

Predisposizione impianto

4. Installato a filo pavimento

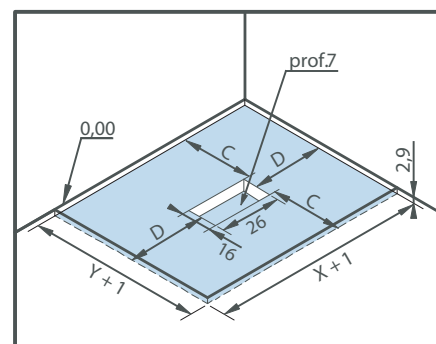
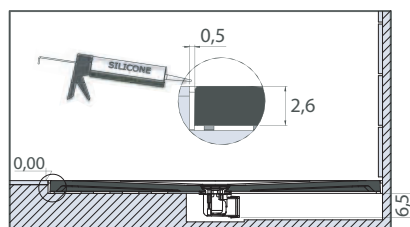
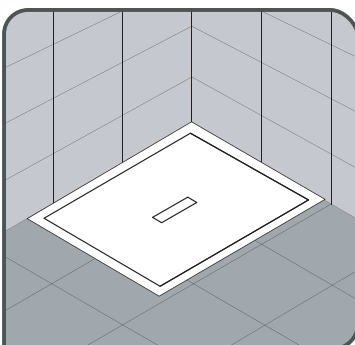

Predisposizione impianto

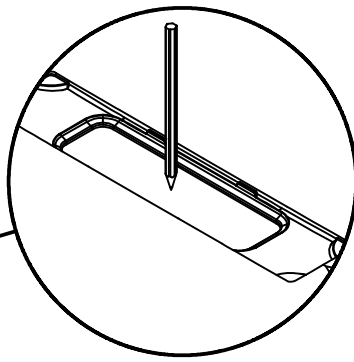
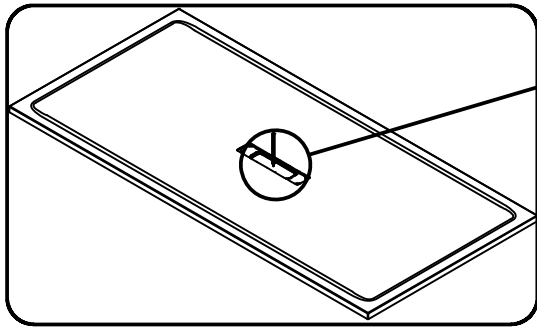

Markeer de positie van de afvoer en
situeer de afvoer en de douchebak
op de gewenste plaats

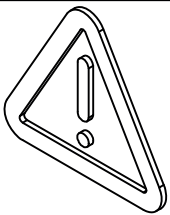
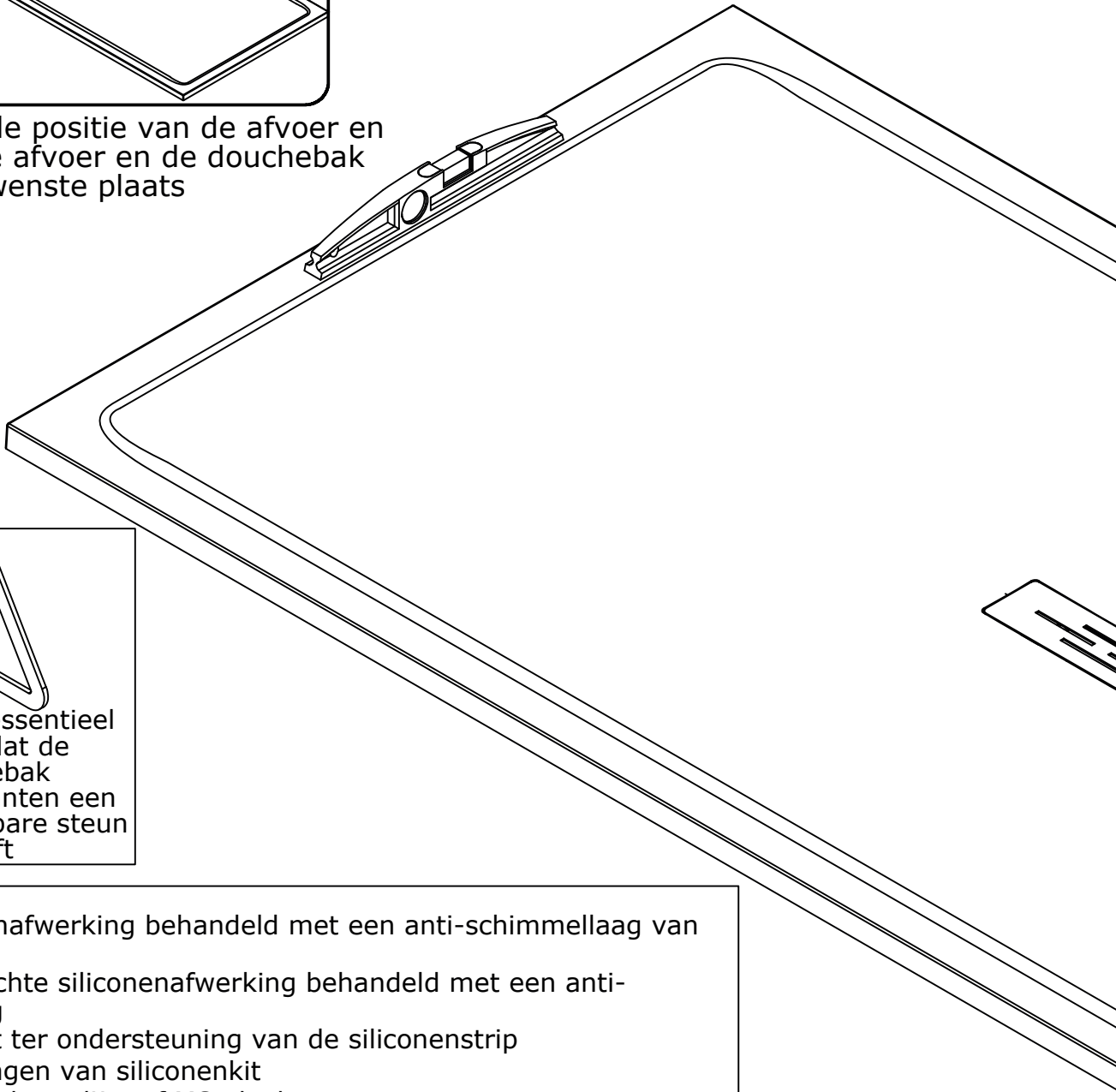

Het is van essentieel
belang dat de
douchebak
aan de zijkanten een
ondoordringbare steun
heeft

- ① - siliconenafwerking behandeld met een anti-schimmellaag van 5mm mino
- ② - waterdichte siliconenafwerking behandeld met een anti-schimmellaag
- ③ - element ter ondersteuning van de siliconenstrip
- ④ - aanbrengen van siliconenkit
- ⑤ - polyurethaan lijm of MS ployleer

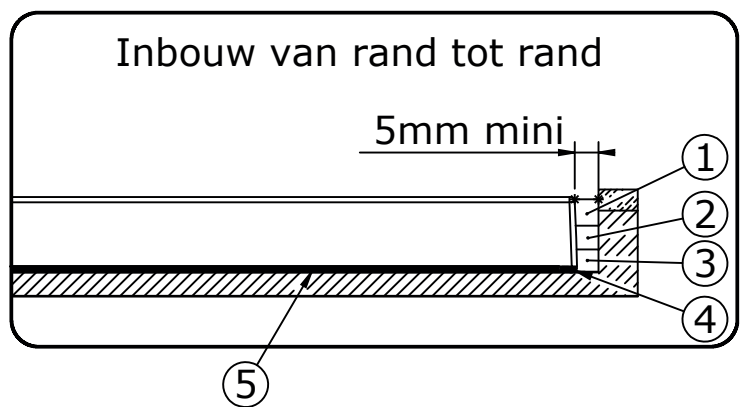
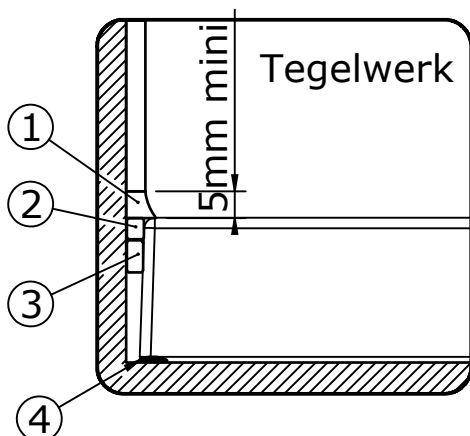



Bescherm de douchebak tijdens de werkzaamheden tegen brandplekken, schokken en beschadigingen door krassen etc...



De Montage van een afdichtingsklep/ventiel is noodzakelijk voor optimaal gebruik indien men een ander sanitair product wil aansluiten op d e zelfde afvoer.

Geen chloorhoudende producten en ontvetters gebruiken!

Plaatsing direct op de vloer

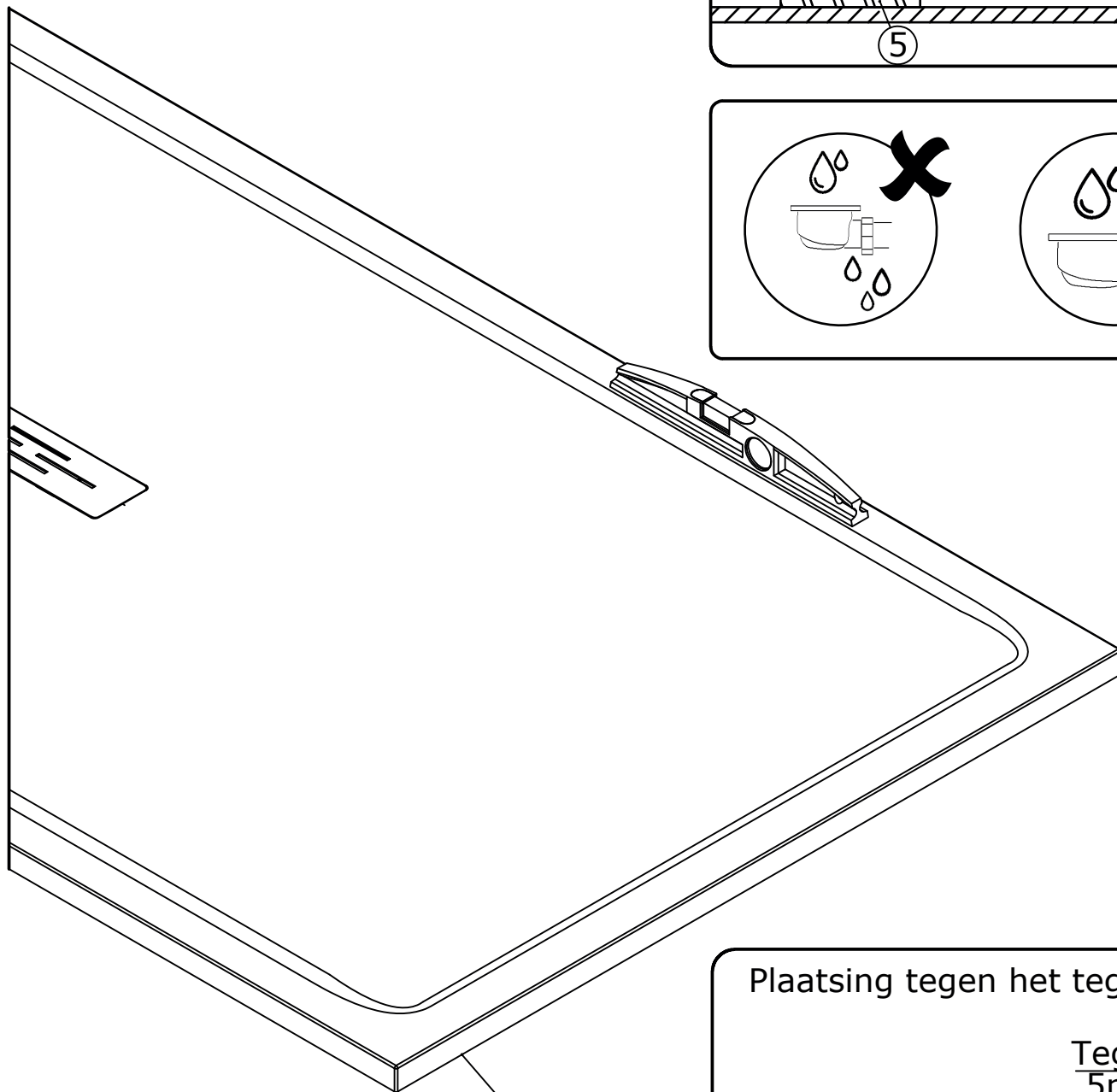
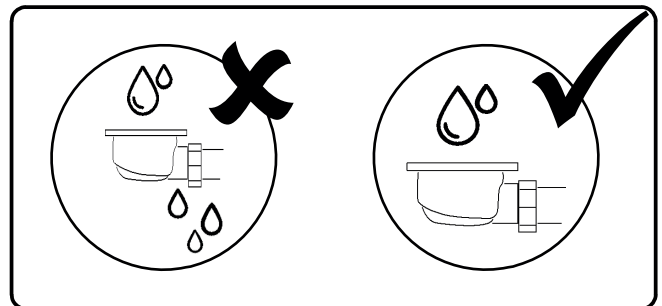
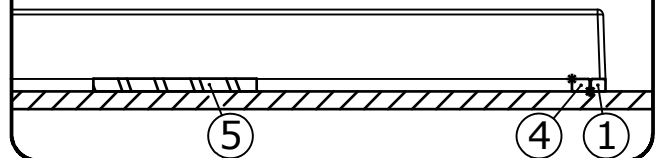

Vlakke niet-vochtige vloer is essentieel

Plaatsing tegen het tegelwerk

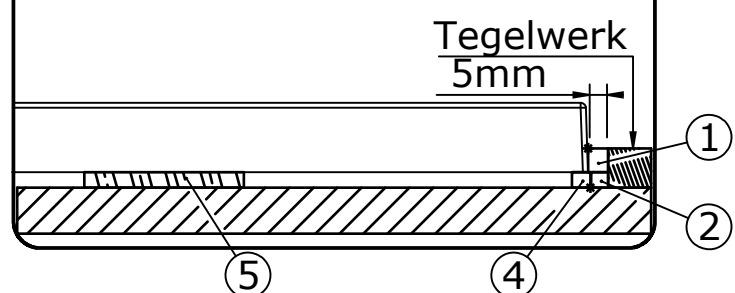

X	Y	C	D
80	80	32	27
90	90	37	32
100	100	42	32
100	80	32	37
100	90	37	37
120	80	32	47
120	90	37	47
120	100	42	47
140	80	32	57
140	90	37	57
140	100	42	57
160	80	32	67
160	90	37	67
160	100	42	67
180	80	32	77
180	90	37	77
180	100	42	77

KINEMOON STYLE

INSTALLATIEMOGELIJKHEDEN

1. Geïnstalleerd op in hoogte verstelbare poten en afgewerkt met tegels

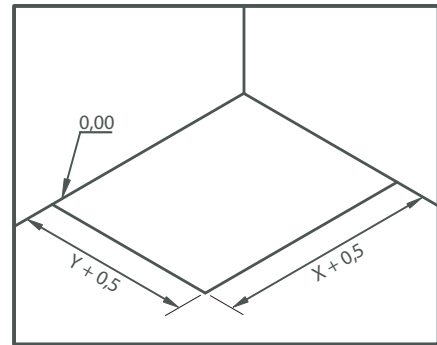
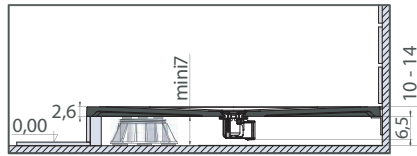

Vorbereitung montage

2. Geïnstalleerd half verzonken tegen de tegels

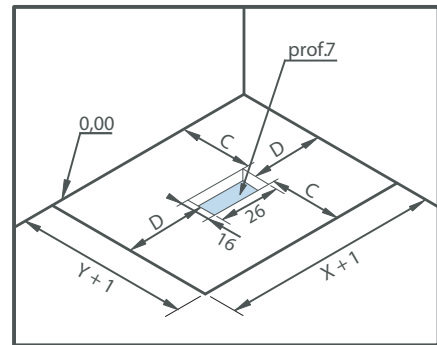
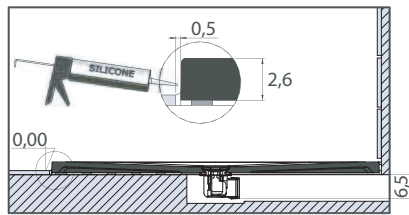
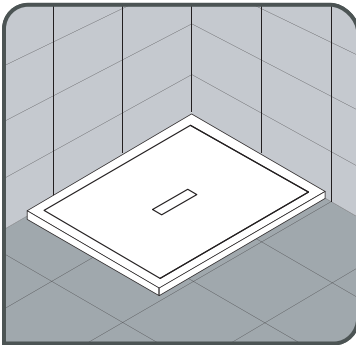

Vorbereitung montage

3. Ingebouwd met in hoogte verstelbare poten

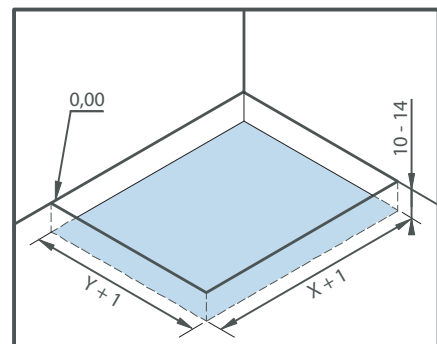
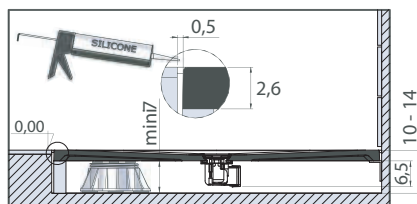

Vorbereitung montage

4. Ingebouwd zonder in hoogte verstelbare poten

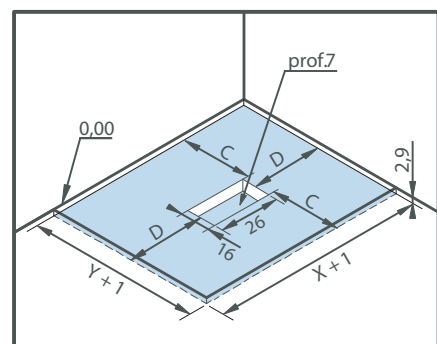
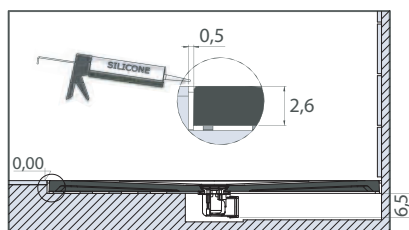
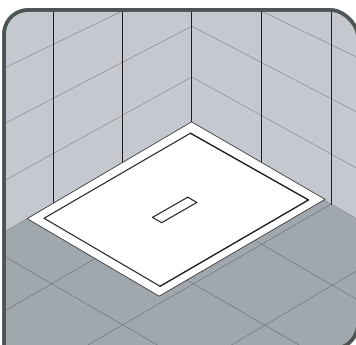

Vorbereitung montage

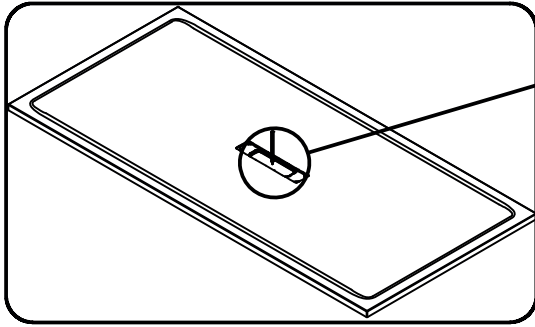

Position für den Ablauf anzeichnen und vormontieren.

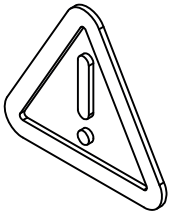
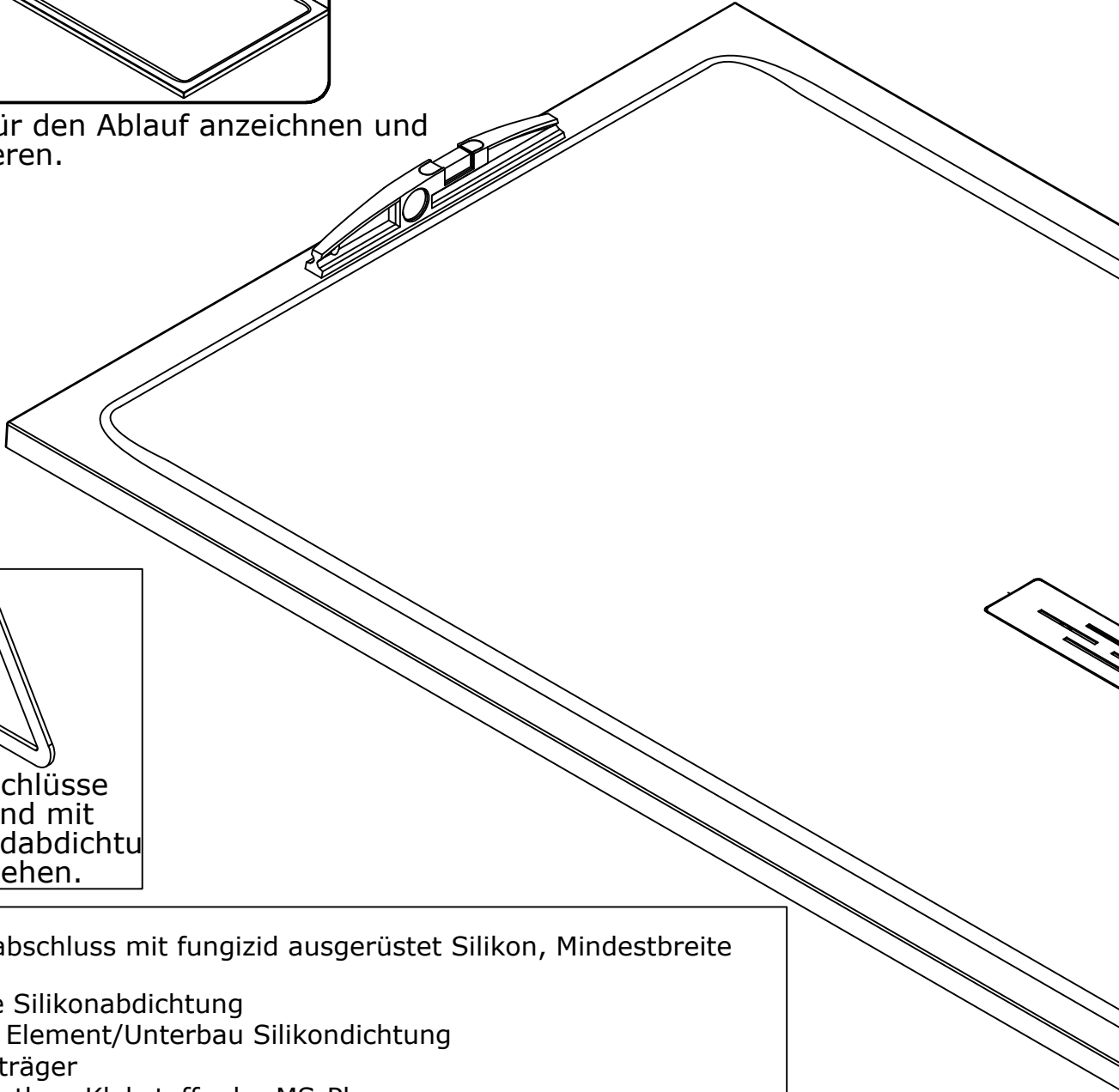
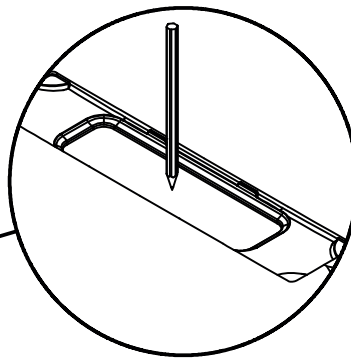

Wandanschlüsse
umlaufend mit
Wannenrandabdichtung
gesehen.

- ① - Fugenabschluss mit fungizid ausgerüstet Silikon, Mindestbreite von 5mm
- ② - flexible Silikonabdichtung
- ③ - Träger Element/Unterbau Silikondichtung
- ④ - Silikonträger
- ⑤ - Polyurethan-Klebstoff oder MS-Polymer

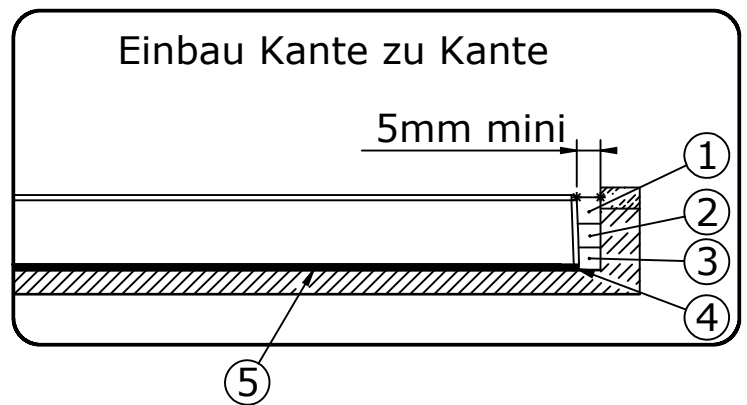
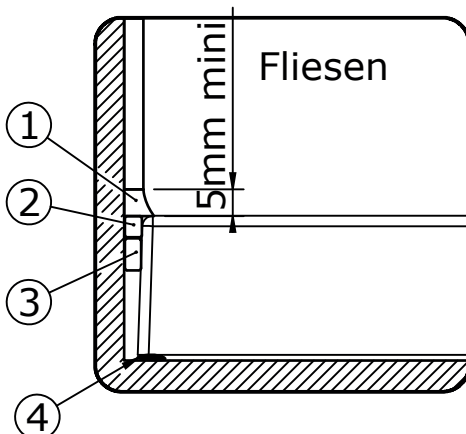



Während den Installationsarbeiten auf ausreichenden Schutz gegen aggressive Mittel achten: Verbrennungen, Stöße, Kratzer oder Abbeizmittel...



Montage eines Rohrbelüfters einplanen, wenn die Anschlussleitung als Sammelanschlussleitung mehrerer Entwässerungsgegenstände geplant wurde.

Verwenden Sie keine säurehaltigen oder andere aggressive Entfetter.

freie Aufstellung auf Fertigfußboden

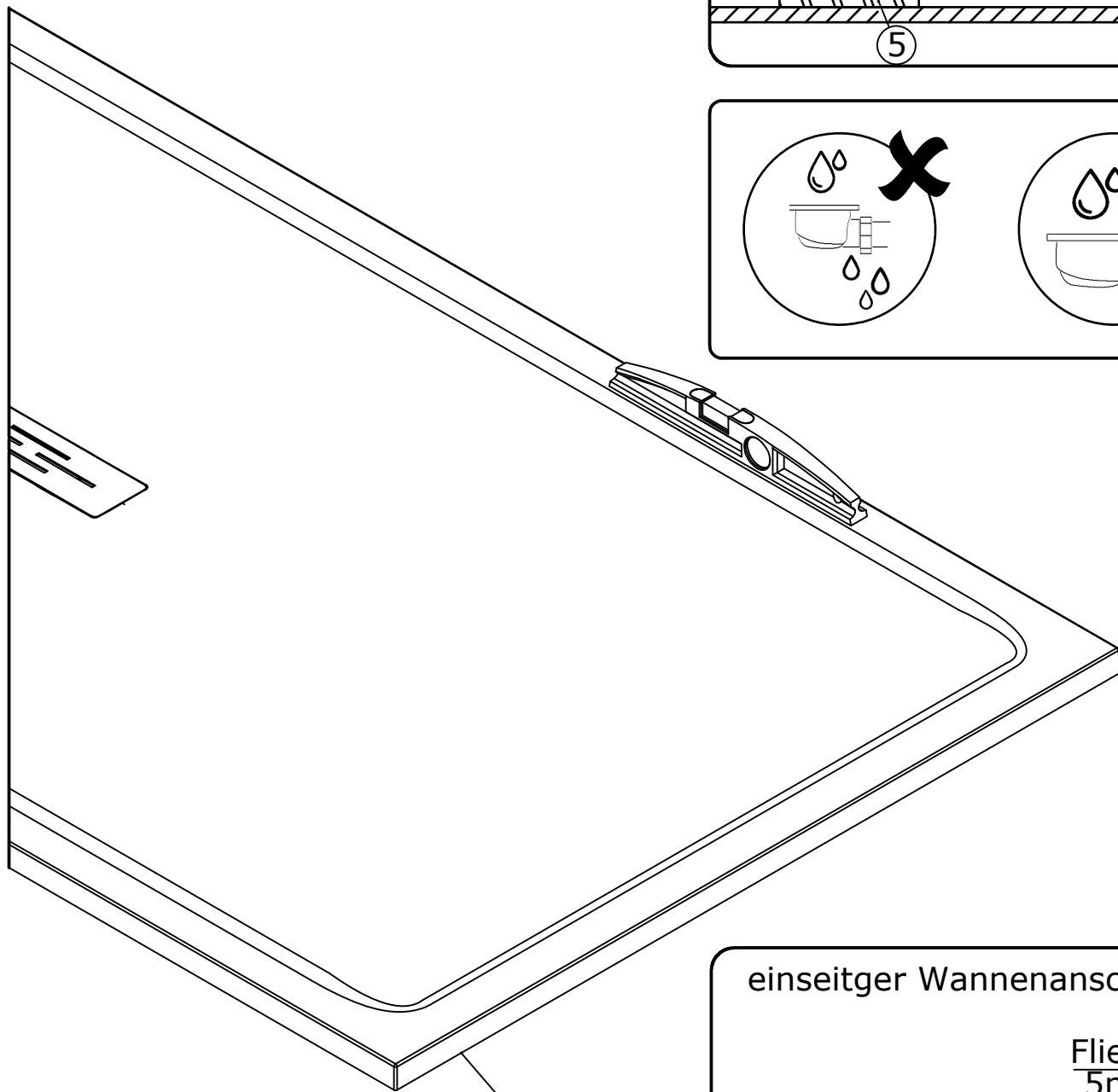
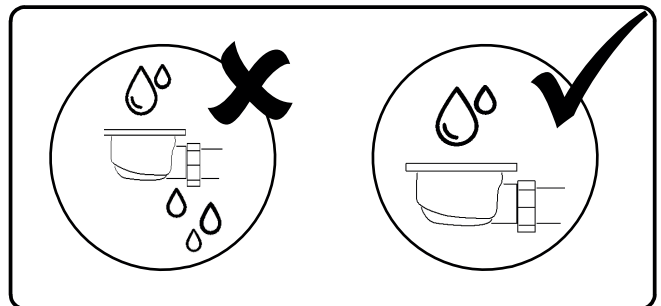
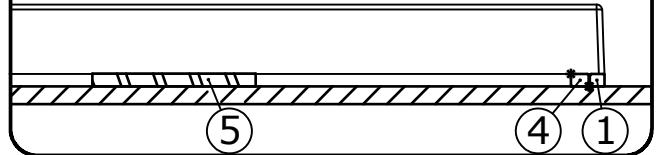

Auf festen, planen und nicht feuchten Boden achten.

einseitiger Wannenanschluß

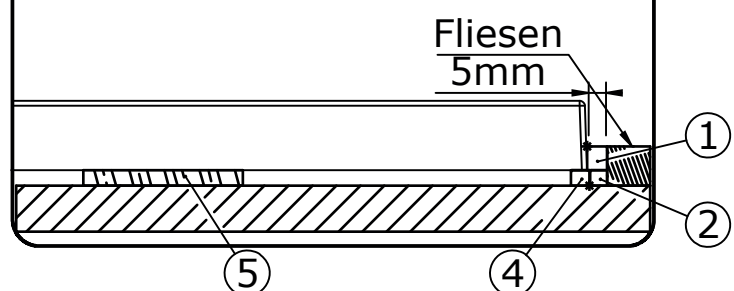

X	Y	C	D
80	80	32	27
90	90	37	32
100	100	42	32
100	80	32	37
100	90	37	37
120	80	32	47
120	90	37	47
120	100	42	47
140	80	32	57
140	90	37	57
140	100	42	57
160	80	32	67
160	90	37	67
160	100	42	67
180	80	32	77
180	90	37	77
180	100	42	77

KINEMOON STYLE

INSTALLATIONSARTEN

1. Montage auf Fertigfußboden mit Wannenfüßen und Fliesensockel

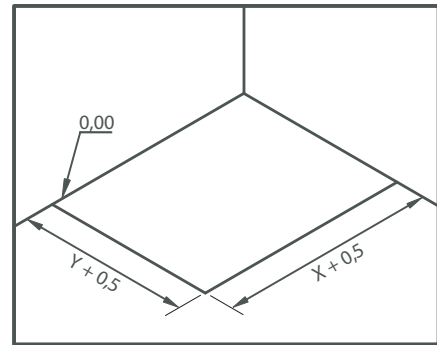
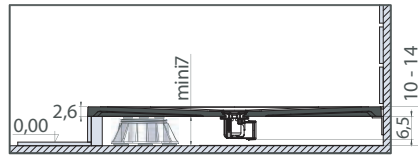
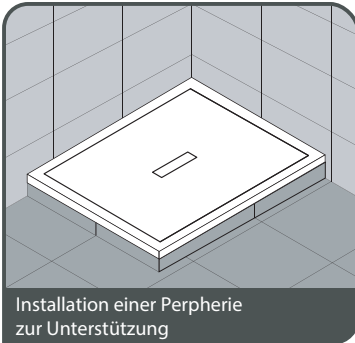

Montagevorbereitung Fertigfußboden mit Wannenfüße

2. Wird im Widerlager gegen die Fliese montiert

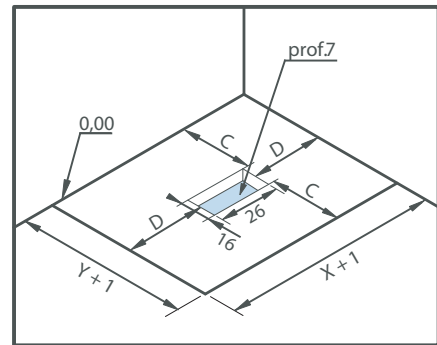
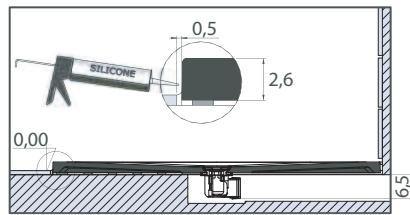
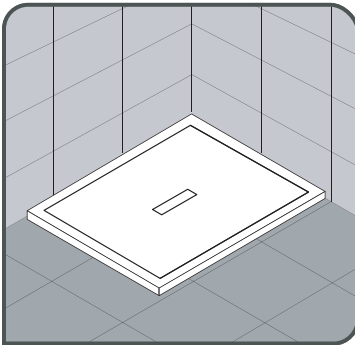

Montagevorbereitung Fertigfußboden mit Wannenfüße

3. Bodengleiche Montage mit Wannenfüße

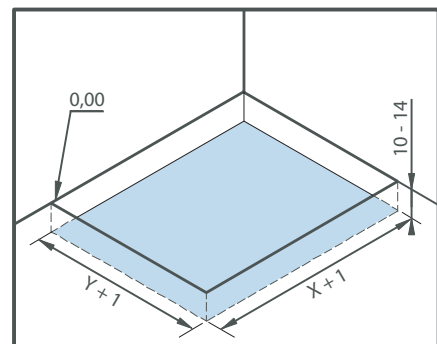
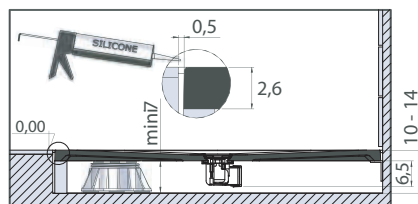
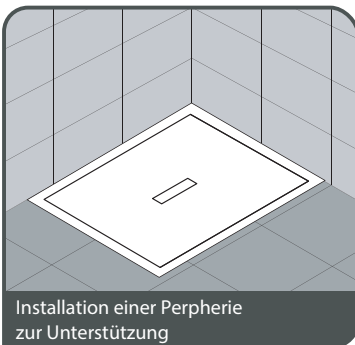

Montagevorbereitung Fertigfußboden mit Wannenfüße

4. Bodengleiche Montage ohne Wannenfüße

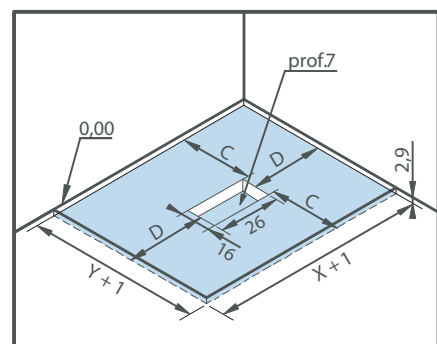
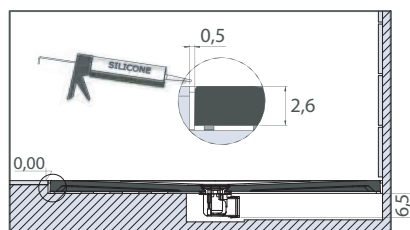
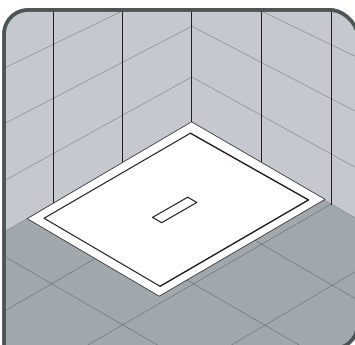

Montagevorbereitung Fertigfußboden mit Wannenfüße

- FR**-Mise en place des plots de colle polyuréthane ou MS polymère
GB-Loading the plots glue polyurethane or MS polymer
ES-Ubicación de los puntos de pegamento poliuretano o polímero MS
PT-Posição dos pontos de cola de poliuretano ou polímero MS
IT-Posizione dei punti di colla poliuretano o MS polimero
NL-Brenng de polyurethaan lijm of MS polymeer aan op de juiste plaats
DE-Bringen Sie den Polyurethan-/MS-Polymere-Kleber auf

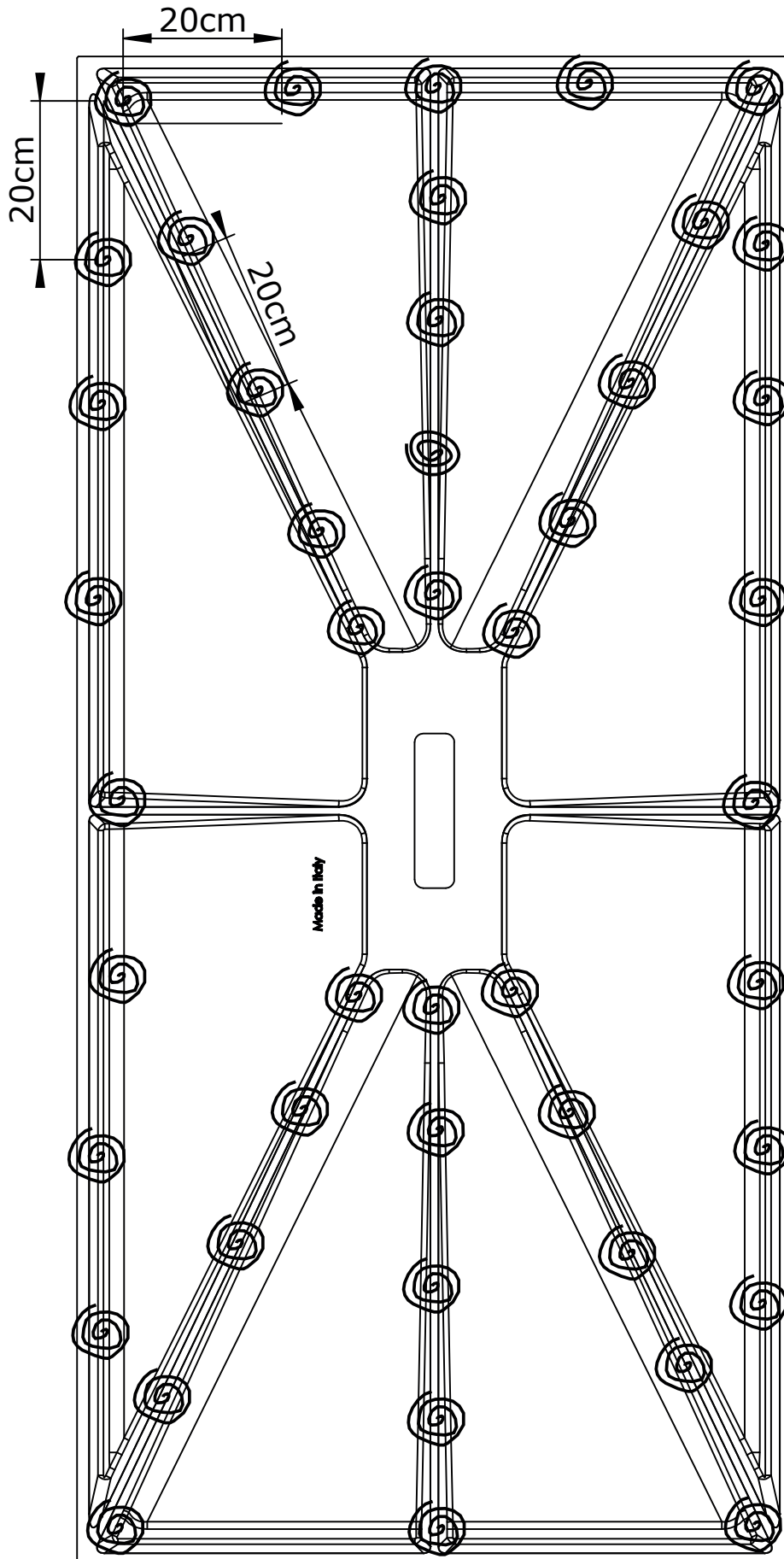

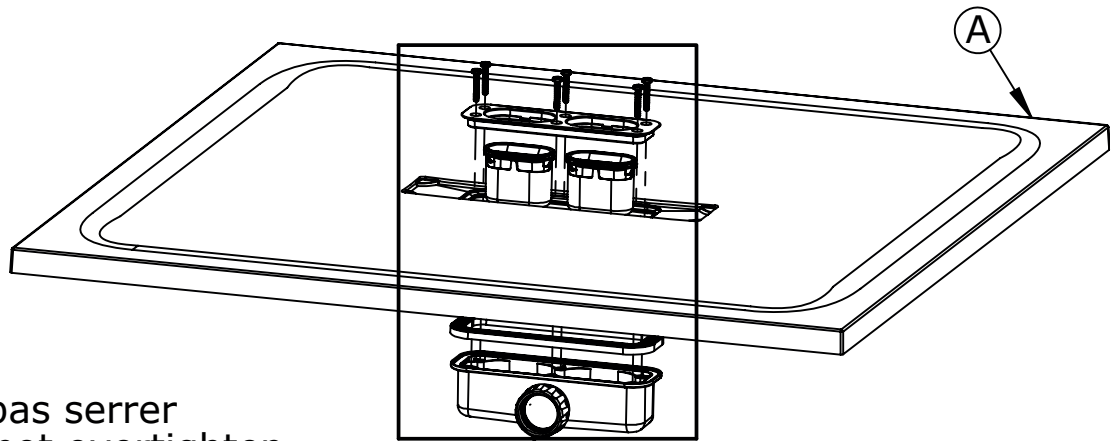

FR-Ne pas serrer
GB-Do not overtighten
ES-No apretar
PT-Não aperte
IT-Non stringere
NL-Niet vast schroeven
DE-Nicht festziehen

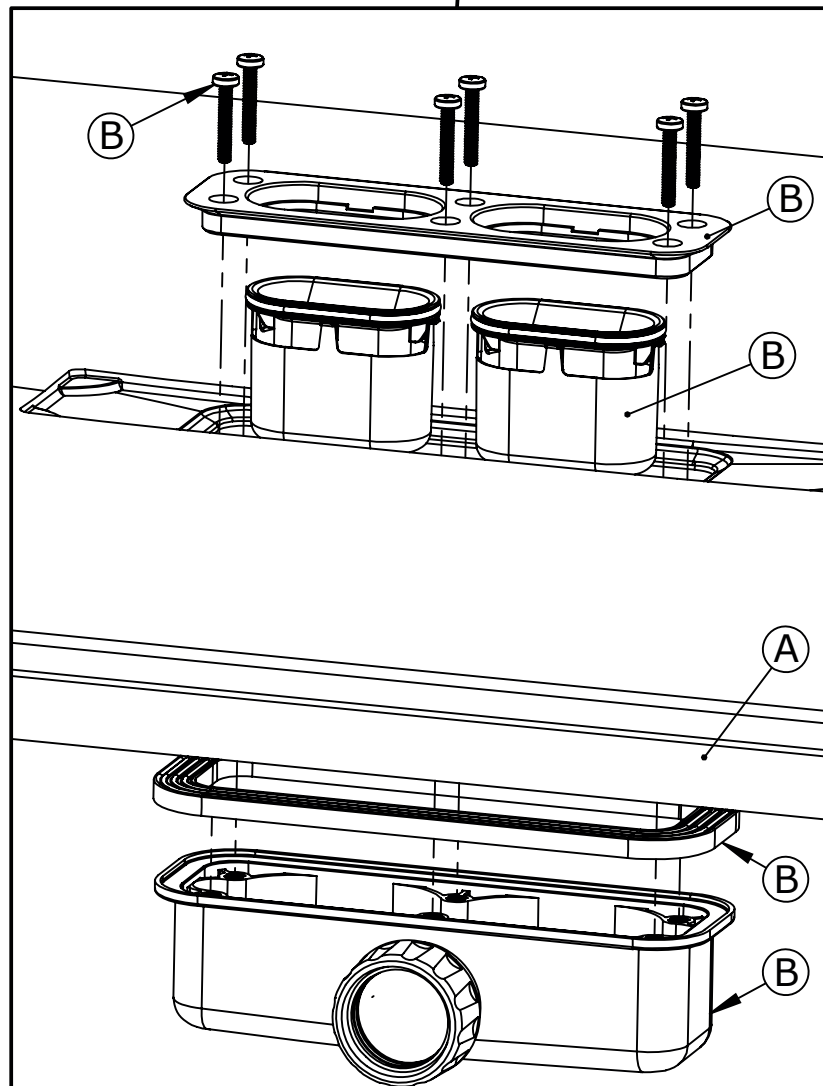



24h

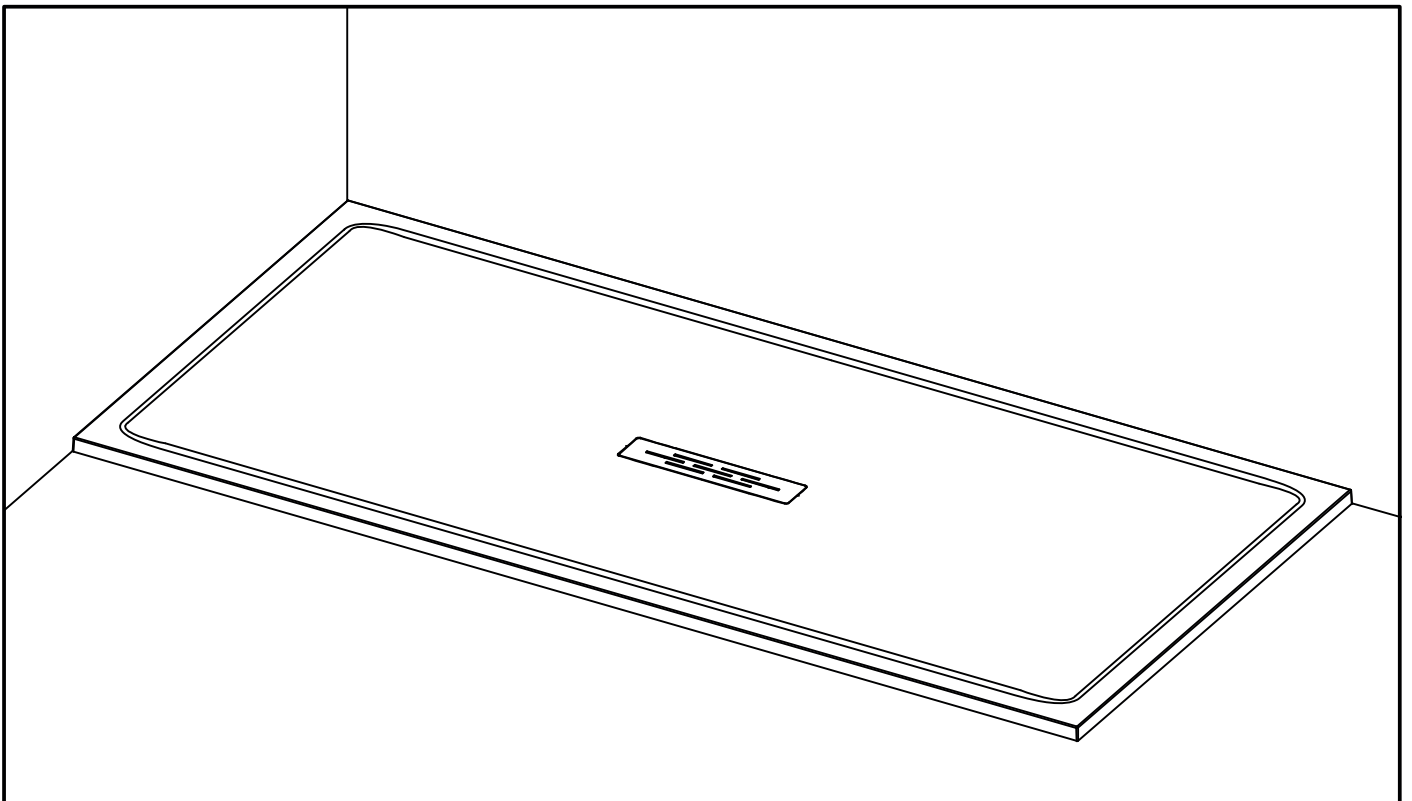



<p>FR</p> <p>Bon de garantie</p> <p>SCANNEZ MOI</p>  <p>http://tiny.cc/bon-de-garantie-fr</p>	<p>GB</p> <p>Guarantee</p> <p>SCAN ME</p>  <p>http://tiny.cc/bon-de-garantie-gb</p>
<p>DE</p> <p>Garantiekarte</p> <p>SCAN MICH</p>  <p>http://tiny.cc/bon-de-garantie-de</p>	<p>NL</p> <p>Garantievoorwaarden</p> <p>SCAN MIJ</p>  <p>http://tiny.cc/bon-de-garantie-nl</p>
<p>ES</p> <p>Garantía</p> <p>ESCANÉAME</p>  <p>http://tiny.cc/bon-de-garantie-es</p>	<p>IT</p> <p>Garanzia</p> <p>SCANSIONAMI</p>  <p>http://tiny.cc/bon-de-garantie-it</p>
<p>PT</p> <p>Garantia</p> <p>ESCANEIE-ME</p>  <p>http://tiny.cc/bon-de-garantie-pt</p>	<p>CH</p> <p>Garantiekarte</p> <p>SCAN MICH</p>  <p>http://tiny.cc/bon-de-garantie-ch</p>
<p>BE</p> <p>Garantievoorwaarden</p> <p>SCAN MIJ</p>  <p>http://tiny.cc/bon-de-garantie-be</p>	<p>AT</p> <p>Garantiekarte</p> <p>SCAN MICH</p>  <p>http://tiny.cc/bon-de-garantie-at</p>



Kinedo

<p>FR Conseils d'entretien</p> <p>SCANNEZ MOI</p>  <p>http://tiny.cc/conseils-entretien-fr</p>	<p>GB Maintenance instructions</p> <p>SCAN ME</p>  <p>http://tiny.cc/conseils-entretien-gb</p>
<p>DE Wartungstipps</p> <p>SCAN MICH</p>  <p>http://tiny.cc/conseils-entretien-de</p>	<p>NL Onderhoudstips</p> <p>SCAN MIJ</p>  <p>http://tiny.cc/conseils-entretien-nl</p>
<p>ES Consejos de mantenimiento</p> <p>ESCANÉAME</p>  <p>http://tiny.cc/conseils-entretien-es</p>	<p>IT Consigli per la manutenzione</p> <p>SCANSIONAMI</p>  <p>http://tiny.cc/conseils-entretien-it</p>
<p>PT Dicas de manutenção</p> <p>ESCANEIE-ME</p>  <p>http://tiny.cc/conseils-entretien-pt</p>	<p>CH Wartungstipps</p> <p>SCAN MICH</p>  <p>http://tiny.cc/conseils-entretien-ch</p>
<p>BE Onderhoudstips</p> <p>SCAN MIJ</p>  <p>http://tiny.cc/conseils-entretien-be</p>	<p>AT Wartungstipps</p> <p>SCAN MICH</p>  <p>http://tiny.cc/conseils-entretien-at</p>

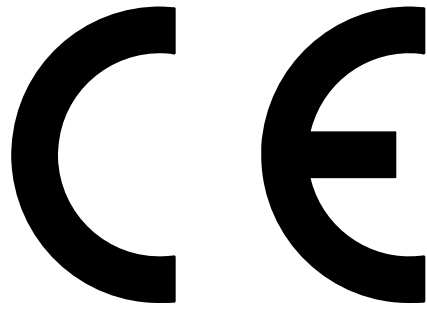

AQUAPRODUCTION, Site industriel,
F - 44680 Chaumes-en-Retz

20

EN 14527 - CL2

Aptitude au nettoyage : satisfaisant

Durabilité : satisfaisant



SERVICE APRÈS-VENTE AFTER-SALES SERVICE

FRANCE

+33 (0)2 40 21 29 45

UK

+44 (0)20 8842 0033

IRELAND

+353 04697 33102

DEUTSCHLAND

+49 (0) 6074 / 30928 0

ITALIA

+39 02 30559420

ÖSTEREICH

+43 1 710 60 70

SUISSE/SCHWEIZ

+41 (0)32 631 04 74

ESPAÑA

+34 93 544 60 76

NEDERLAND

+31 475 487 100

BELGIQUE/BELGIË

+31 475 487 100

РОССИЯ

+7 495 258-29-51

PORTUGAL

+351 219 112 785